

F-100 SR

Fixed Position 1D Linear Imager Scanner (80mm width model)



This manual provides specifications for the F-100 SR fixed position 1D scanner.

The information in this document is subject to change without notice.

Document History

Model Number:	F-100 SR	Specification Number:	SS17028
Edition:	2nd	Original Spec Number:	(SS17027)
Date:	27-November-2018		

© 2018 Opticon. All rights reserved.

This manual may not, in whole or in part, be copied, photocopied, reproduced, translated or converted to any electronic or machine readable form without prior written consent of Opticon.

Limited Warranty and Disclaimers

Please read this manual carefully before installing or using the product.

Serial Number

A serial number appears on all Opticon products. This official registration number is directly related to the device purchased. Do not remove the serial number from your Opticon device. Removing the serial number voids the warranty.

Warranty

Unless otherwise agreed in a written contract, all Opticon products are warranted against defects in materials and workmanship for two years after purchase excluding batteries. Opticon will repair or, at its option, replace products that are defective in materials or workmanship with proper use during the warranty period. Opticon is not liable for damages caused by modifications made by a customer. In such cases, standard repair charges will apply. If a product is returned under warranty and no defect is found, standard repair charges will apply. Opticon assumes no liability for any direct, indirect, consequential or incidental damages arising out of use or inability to use both the hardware and software, even if Opticon has been informed about the possibility of such damages.

Packaging

The packing materials are recyclable. We recommend that you save all packing material to use should you need to transport your product or send it for service. Damage caused by improper packaging during shipment is not covered by the warranty.

Trademarks

Trademarks used are the property of their respective owners.

Opticon Inc. and Opticon Sensors Europe B.V. are wholly owned subsidiaries of OPTOELECTRONICS Co., Ltd., 12-17, Tsukagoshi 4-chome, Warabi-shi, Saitama, Japan 335-0002. TEL +81-(0) 48-446-1183; FAX +81-(0) 48-446-1184

Support

USA

Phone: 800-636-0090
Email: support@opticonusa.com
Web: www.opticonusa.com

Europe

Phone: +31235692728
Email: support@opticon.com
Web: www.opticon.com

Revision History

Product Name : F-100 SR

Edition	Date	Page	Section	Description of Changes
First	2018/02/21	-	-	
Second	2018/11/27	2	3.1	Delete USB from standard (both SR and WA)
		3	4	Revise Power Section, Operating voltage: 5.0V ±5% → DC 4.75 – 5.25 V
		4	3	Correct "Rumble at 3000Hz when reading success" to "Sounds a tone at 3000Hz on a successful read". Revise Supported 1D Symbologies, Note: Ambient Light: 500 to1000lx → 500 to1500lx
			4	Revise Regulatory Compliance, EMI/RFI: VCCI/EN55032/FCC Class B → VCCI クラス B / FCC Class B / EN 55032 Class B Revise Regulatory Compliance, Electromagnetic compatibility (EMC): EN55024 (EN61000-6-1) Class B → EN 55024, delete note.
		9	8	Revise Conditions, Ambient Light unit: "lux" → "lx"
			8.1	Revise Code39: Resolution 0.15mm, Barcode width: 60 mm → 50 mm, Digits: 10 → 19 Resolution 0.19mm → 0.2 mm
		11	8.4	Revise Conditions, Barcode: resolution = 0.19 mm → 0.2mm
		12	8.7	Revise Conditions, Barcode: "Code39. Resolution = 0.19mm / PCS 0.9, specified in Section 8.1." → "EAN/JAN. Resolution = 0.26mm / PCS 0.9 / 13 digits, specified in Section 8.1."
		15	9.1.4	Update Figure 11: Interface Circuit (RS-232C D-sub 9pin)
		17	9.2.4	Update Figure 13: Interface Circuit (RS-232C Loose End)
		18	9.3	Add note: USB-HID interface model uses OS standard driver. Driver installation is unnecessary in the environments where the HID keyboard operates. F- 100 SR can be use just by connecting the USB.
		19	9.3.4	Update Figure 16: Interface Circuit (USB)
		24	11.2	Delete IEC/EN.
			11.3	Update "VCCI-CISPR 32:2016 Class B" to "VCCI-CISPR 32:2016 クラス B"
			12	Update RoHS
		25	14	Revise Precautions
		28	16.1	Update Figure 24: Individual Packaging (RS-232C)
		29	-	Delete section "16.2 Individual Packaging Specification (USB)" and "Figure 25 Individual Packaging (USB)".
			16.2	Update Figure 25: Collective Packaging
		33	18.3.2	Update to USB-COM.
		-	-	Delete section 19. Optional AC Adapter

Contents

1	Abstract	1
2	Overview	1
3	Model details	2
3.1	Standard	2
3.2	Model Description	2
4	Basic Specifications	3
5	Detailed View	5
5.1	Detailed View	5
5.2	LED Indicator Specifications	6
6	Electrical Specifications	7
6.1	RS-232C Specification	7
6.2	USB Specification	7
7	Optical Specifications	8
7.1	Basic Optical Specifications	8
7.2	Focal Plane	8
7.3	Optical Axis and Dead Zone	8
8	Technical Specifications	9
8.1	Barcode Test Sample	9
8.2	Scan Area	10
8.3	Depth of Field	10
8.4	Printed Contrast Signal (PCS)	11
8.5	Minimum Resolution	11
8.6	Barcode Width	11
8.7	Pitch, Skew and Tilt	12
8.8	Curvature	12
8.9	Motion Tolerance	13
9	Interface Specification	14
9.1	RS-232C Interface (D-Sub 9pin)	14
9.1.1	Initial Communication Settings	14
9.1.2	Signal Specification	14
9.1.3	Pin Assignment	14
9.1.4	RS-232C D-Sub 9pin Circuit	15
9.1.5	RS-232C D-Sub 9pin Interface Cable	15
9.2	RS-232C Interface (Loose End)	16
9.2.1	Initial Communication Settings	16
9.2.2	Signal Specification	16
9.2.3	Pin Assignment	16
9.2.4	RS-232C Loose End Circuit	17
9.2.5	RS-232C Loose End Interface Cable	17
9.3	USB Interface	18

9.3.1	USB Interface Specifications	18
9.3.2	USB Connector	18
9.3.3	USB Interface Circuit	19
9.3.4	USB Interface Cable	19
10	Environmental Specifications	20
10.1	Temperature	20
10.2	Humidity.....	20
10.3	Ambient Light Immunity.....	21
10.4	Dust and Drip Proof	21
10.5	Scan Key Durability	22
10.6	Cable Strength	22
10.7	Cable Bending Strength	22
10.8	Vibration Strength (without packing)	23
10.9	Vibration Strength (in individual packing)	23
10.10	Drop Impact Strength (without packaging)	23
10.11	Drop Impact Strength (in individual packaging).....	23
10.12	Electrical Specifications.....	23
11	Regulatory Compliance	24
11.1	LED Safety	24
11.2	Product Safety.....	24
11.3	EMC.....	24
12	RoHS	24
13	Reliability	24
14	Precautions.....	25
15	Product Display	27
15.1	Product Label	27
15.2	UL Label	27
16	Packaging Specifications	28
16.1	Individual Packaging Specification (RS-232C).....	28
16.2	Collective Packaging Specification	29
17	Physical Features.....	30
17.1	Dimensions.....	30
17.2	Weight	30
17.3	Mechanical Drawing	30
18	Factory Setting	31
18.1	Default Setting (Part 1: Readable Codes).....	31
18.2	Default Setting (Part 2: Read Options, Illumination LED, Trigger, Buzzer)	32
18.3	Default Setting (Part 3: Communication Settings).....	33
18.3.1	RS-232C	33
18.3.2	USB.....	33

Table of Figures

Figure 1: Detailed View of F-100 SR.....	5
Figure 2: Reading distance.....	8
Figure 3: Optical axis and Dead zone	8
Figure 4: Scan area and resolution	10
Figure 5: Barcode width.....	11
Figure 6: Pitch, Skew and Tilt.....	12
Figure 7: Curvature.....	12
Figure 8: Barcode moving vertically	13
Figure 9: Barcode moving horizontally	13
Figure 10: RS-232C D-Sub9pin Connector.....	14
Figure 11: Interface Circuit (RS-232C D-sub 9pin)	15
Figure 12: RS-232C D-sub 9pin Interface Cable.....	15
Figure 13: Interface Circuit (RS-232C Loose End).....	17
Figure 14: RS-232C Loose End Interface cable.....	17
Figure 15: USB Plug (A) Pin Assignment.....	18
Figure 16: Interface Circuit (USB)	19
Figure 17: USB Interface Cable	19
Figure 18: Ambient Light Immunity.....	21
Figure 19: Scan key durability	22
Figure 20: Cable Bending Strength	22
Figure 21: Drop Impact Strength	23
Figure 22: Product Label	27
Figure 23: UL Label	27
Figure 24: Individual Packaging (RS-232C)	28
Figure 25: Collective Packaging	29
Figure 26: Mechanical Drawing	30

1 Abstract

This manual provides specifications for the F-100 SR, a small and high performance fixed mount 1D linear imager scanner capable of reading up to 80mm wide barcodes.

2 Overview

The F-100 SR is a small size fixed position 1D linear imager scanner that allows for high speed reading of up to 80mm wide barcodes at a distance of 35mm. Its main features are as follows:

- **Industry's smallest size**
A new optical system enabled us to create the smallest fixed mount scanner in the industry without compromising the performance.
- **High-speed 700 scans/second**
Industry's fastest class 700 scans/second makes reading of high speed moving barcodes possible.
- **Reliable reading**
Reliable and instant reading of up to 80mm wide barcodes at a distance of 35mm.
- **Installation assistant function**
The F-100 features a read rate mode in which the reading performance is indicated by a 3-color status LED and the buzzer. This mode greatly simplifies the optimal installation in your application.
- **Configure / Waveform acquisition application**
To configure the F-100, the "Universal Config" PC program is available which can generate serial commands and menu barcodes. It is also possible to acquire waveforms for analysis of the reading performance.
- **120mm width model**
The F-100 SR is capable of reading up to 80mm wide barcodes at a distance of 35mm. For applications that use wider barcodes there is also the WA model, capable of reading up to 120mm wide barcodes at a distance of 64mm. This allows for the use of an imager based scanner in applications that were previously only possible with laser scanners.
- **The scanner is a RoHS compliant product as declared by OPTOELECTRONICS Co., Ltd.**

3 Model details

The F-100 model name is constructed by a combination of following.

Model name	Focus	Interface	Cable length	Optional AC Adapter
F-100	SR or WA	-RS232C	None	None or +PS
		-USB-COM or -USB or -RS232C(9P) or -RS232C(LE)		None

3.1 Standard

The following specs are the standard products.

Standard	Description
F-100 SR-RS232C	80mm width model, RS-232C
F-100 WA-RS232C	120mm width model, RS-232C

Note: Other combinations only as special order, please contact sales offices for this.

3.2 Model Description

- Reading width / Focus

Symbol	Description
SR	80mm width model (focus distance: 35mm)
WA	120mm width model (focus distance: 64mm)

- Interface Cable

Symbol	Description
-RS232C	RS-232C cable (external AC adapter power supply spec) is connected.
-USB-COM	USB cable is connected and interface default setting is USB-COM.
-USB	USB cable is connected and interface default setting is USB-HID.
-RS232C(9P)	RS-232C cable (power supply input connected to D-sub 9 pin 9) is connected.
-RS232C(LE)	RS-232C loose end cable is connected.

- Cable length

Symbol	Description
None	Cable length 2.0m

Note: Interface cable length is customizable only as special order.

- Optional AC adapter

Symbol	Description
None	AC adapter not included.
+PS	AC adapter for RS-232C external power supply is included.

4 Basic Specifications

Item		Specification	Note	
Interface	RS-232C	150 to 115,200 bps	Default: 9600 bps	
	USB	Full Speed 12 Mbps (HID/COM)		
Indicator	Status LED	Upper panel 3 colors LED (Green, Orange, Red)		
	Buzzer	Sounds a tone at 3000Hz on a successful read.		
Optical Section	Linear Sensor Technology	Linear imager sensor		
	Effective pixels	2496 x1 pixels		
	Scan rate	700 scan/sec		
	Light source	Red LED x 2pcs	Wavelength: 624nm	
Supported 1D Symbolologies	Symbologies	1D Code	UPC-A/E, UPC Add-on, EAN-13/8, EAN Add-on, JAN-13/8, Industrial 2 of 5, IATA, Interleaved 2 of 5, Codabar, Code 39, Code 93, Code 128, MSI/Plessey, ISBN code, Code-11, Korean Postal Authority code(Code 3 of 5), UK/Plessey, GS1 DataBar(RSS), S-Code, Telepen, Tri-Optic	
	Minimum resolution		Code 39: 0.125mm	
	Curvature		Radius ≥ 30 mm (EAN/JAN-13) Radius ≥ 20 mm (EAN/JAN-8)	
	Barcode width		Possible to read: Code 39 with 80 mm width and resolution 0.19mm (DOF: 35 mm)	
	Depth of Field	Code 39	Resolution (0.125-)	30 - 40mm
			Resolution (0.19-)	25 - 45mm
	Scan angle		Pitch	$\pm 6^\circ$
			Skew	$-30^\circ \leq \beta \leq -10^\circ$, $10^\circ \leq \beta \leq 30^\circ$
			Tilt	$\pm 10^\circ$
	Minimum PCS		0.45 or higher	
Power Section	Operating voltage		DC 4.75 – 5.25 V	
	Current consumption	Reading	340mA (Typ), 500mA(Max)	
		Standby	100mA (Typ)	
			Ambient temperature: 25°C	

Note: This product is intended to be supplied by a Listed Power Unit marked "Class 2" or "LPS" and rated from 5Vdc $\pm 5\%$, minimum 0.5A.

Item		Specification	Note	
Environmental Specifications	Temperature	Operating	0 to 40°C	
		Storage	-10 to 60°C	
	Humidity	Operating	20 to 85% (No condensing, no frost)	
		Storage	20 to 90% (No condensing, no frost)	
	Ambient light immunity	Fluorescent light Incandescent light	5,000 lx or less	EAN/JAN 0.26mm Optical axis angle 75° Distance 35 mm
		Sun light	10,000 lx or less	
		Vibration	Vary the frequency of vibration from 10 Hz to 100 Hz at an acceleration velocity of 19.6m/s ² for 60 minutes in X, Y and Z-directions	
Drop	Drop the scanner 18 times (6 faces x 3) from the height of 60 cm onto a concrete floor			
Dust and drip proof	IP42 equivalent			
Regulatory Compliance	Product safety	UL60950-1, CSA C22.2 No.60950-1-07		
	LED safety	IEC 62471:2006 Exempt Risk Group	Peak Wavelength : 624 nm	
	EMI/RFI	VCCI クラス B / FCC Class B / EN 55032 Class B	For residential, commercial and light-industry environments	
	European conformity	CE marking		
	Electromagnetic compatibility (EMC)	EN 55024		
Immunity Test	ESD immunity	No destruction	Air discharge (direct): ±15 kV	Condition: IEC61000-4-2 compliant
		No malfunction	Contact discharge (direct / indirect): ±6kV Air discharge (direct): ±8 kV	
	Radio-frequency electromagnetic field. Amplitude modulation	Frequency	80 to 1000 MHz	Condition: IEC61000-4-3 compliant
		Level	3 V/m	
		AM	80% (AM)	
	Fast transient	Voltage	Alternating-current input cable: ±1 kV	Condition: IEC61000-4-4 compliant
		Pulse	5 / 50 ns (Tr / Tw)	
		Frequency	5 kHz	
	Surge	Pulse	1.2 / 50 ns (Tr / Th)	Condition: IEC61000-4-5 compliant
		Voltage	From L to P : ±2 kV (closed-loop voltage)	
			From L to L : ±1 kV (closed-loop voltage)	
	Radio-frequency common mode	Frequency	0.15 to 80 MHz	Condition: IEC61000-4-6 compliant
		Level	3 V	
		AM	80% (AM)	
	Power frequency magnetic field	Frequency	50 and 60 Hz	Condition: IEC61000-4-8 compliant
Level		3 A/m		
Voltage dip, momentary voltage drop, fluctuation	Dip 1	Drop 30%, 0.5 cycles	Condition: IEC61000-4-11 compliant	
	Dip 2	Drop 60%, 5 cycles		
	Momentary drop	Drop 95%, 250 cycles		
Physical Features	Dimensions	Approx. 45.5 (W) ×20.25 (D) ×19 (H) (mm)	Except protruding portion	
	Weight	Approx. 15g	Excluding the cable	
	Housing color	Black		
	Switch plate color	Black		

5 Detailed View

5.1 Detailed View

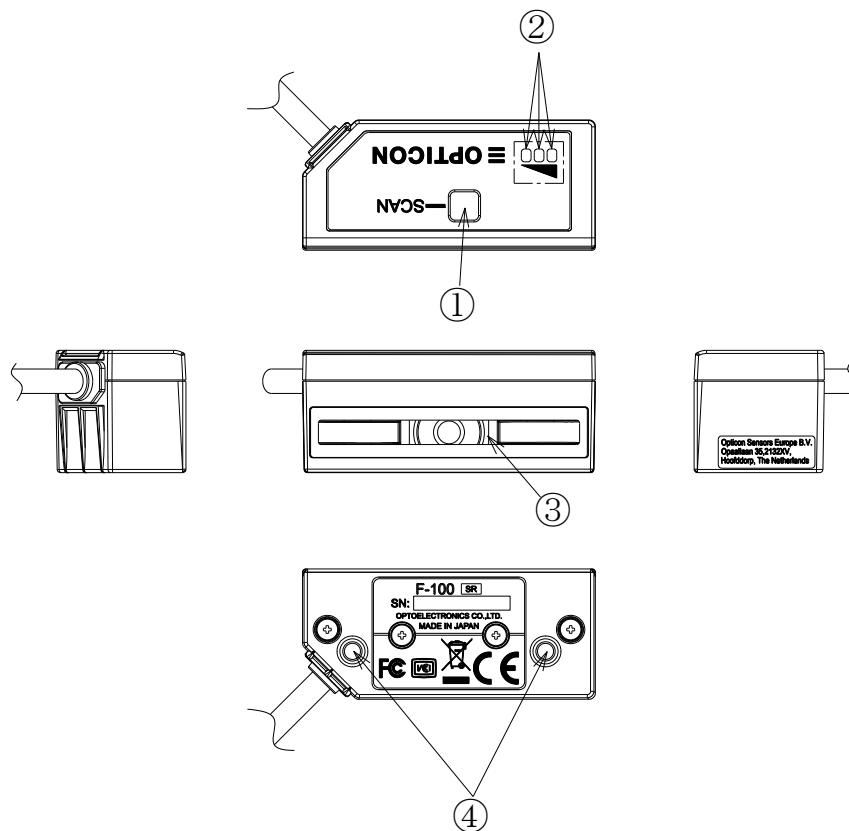

Figure 1: Detailed View of F-100 SR

No.	Name	Description
1	Scan key	By pressing this key, the scanner starts reading barcodes. Pressing for more than 5seconds, the scanner shifts to read rate mode. Ends by pressing key again or inputting trigger signal.
2	Status LEDs	Indicates reading result and USB communication status. In read rate mode, the read rate is indicated by these 3-color LEDs. Refer to section 5.2 for details.
3	Scan Window	Light paths of the imager and LED illumination. Ensure that the lens is free from dust and dirt before scanning.
4	Mounting holes	Screw holes that can be used to mount the scanner. Screw hole is M3, maximum depth is 4mm and tightening torque is 0.5 Nm.

5.2 LED Indicator Specifications

The status LED's indicate the reading result and USB communication status. In read rate mode, the reading success rate is indicated by these three 3-color LED's. Below is a more in-depth description on these LED's.

- Normal LED indication

LED	Status	LED	Status	LED	Status
	Reading success		Waiting for USB connection		Communication/ reading error

- Read rate mode LED indication

By pressing the scan key for more than 5 seconds or by sending a serial command, the scanner shifts to read rate mode. The status LED's then show the read rate according to the following table. To exit read rate mode, either press the scan key, send a serial command or activate the trigger signal.

Reading rate	Less than 50%	Less than 75%	Less than 95%	95% or more	Marking beside status LED
Status LED	 	 	 	 	

* Status LED legend

: OFF : Blinking : ON

Note: Refer to the user's manual for more details.

6 Electrical Specifications

The F-100 consists out of an 'Imager Section', a decoder section that decodes the signal coming from the imager section, a 'Communication Control Section' that takes care of the communication with a host and finally a 'Power Supply Section' that generates the power supply voltages for the entire scanner.

6.1 RS-232C Specification

Input power supply voltage	DC 5.0 V
Range of working voltage	4.75 to 5.25 V
Power ripple	100 mVp-p max (10 to 100 kHz, power supply voltage 5.0 V)
Current consumption*	340 mA (Typ.), 500mA (Max) during reading operation 100 mA (Typ.) in stand-by mode

6.2 USB Specification

Input power supply voltage	500 mA (High-Power)
Current consumption*	340 mA (Typ.), 500mA (Max) during reading operation 100 mA (Typ.) in stand-by mode

* The current consumption was measured at 25°C.

The current consumption was measured by placing a 1Ω series resistor in the power supply lines and by measuring the voltage across this resistor.

Current value may very depend on the connected host type.

7 Optical Specifications

7.1 Basic Optical Specifications

Item	Characteristics
Scanning Technology	Linear imager sensor
Number of effective pixels	2496 x 1 pixels
Image capture speed (*1)	700±10% scan/s
Focal distance	35mm
Illumination light source (LED x 2)	624nm

*1 The fastest speed of image capture

7.2 Focal Plane

The focal plane is located at 35mm from the front of the scanner. This is the position where the optical performance is at its best. It is recommend to set the barcode at this position, especially when reading a high resolution or a low PCS barcode. It is possible to read up to 80mm wide barcodes at this distance.

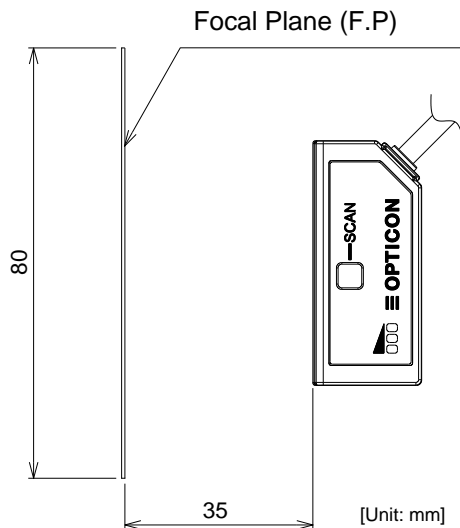

Figure 2: Reading distance

7.3 Optical Axis and Dead Zone

The optical axis is at 6.25±1mm from the bottom of the scanner. Please make sure to position the barcode in this area and respect the possible tolerance. Make sure to tilt the barcode at least by ±10°. The scanner may be unable to read when the barcode has a tilt angle between 0° and ±10° due to specular (mirror like) reflection.

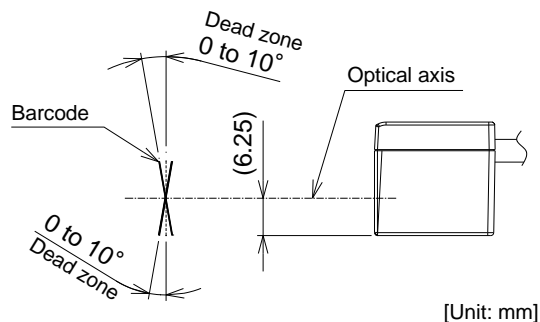

Figure 3: Optical axis and Dead zone

8 Technical Specifications

The conditions for technical specifications are as follows, unless otherwise specified in each section.

Conditions

Ambient Temperature and Humidity	Room temperature, room humidity
Ambient Light	500 to 1500 lx
Angles	$\alpha = 0^\circ$, $\beta = +15^\circ$, $\gamma = 0^\circ$ (refer to figure 6)
Curvature	$R = \infty$
Power Supply Voltage	5.0 V
PCS	0.9 or higher
Scanning Test	More than 630 times success during 700 scans.
Barcode Test Sample	Specified in each section

8.1 Barcode Test Sample

Code39

Resolution	Code type	PCS	Barcode width*	Quiet Zone	Digits
1.0mm	Code 39	0.9	53mm	20mm	1
0.5mm			54mm	10mm	4
0.25mm			42mm	5.1mm	8
0.19mm			60mm	5.1mm	17
			80mm	5.1mm	24
0.15mm			50mm	5.1mm	19
0.125mm			16mm	5.1mm	4
0.2mm		0.45	60mm	5.1mm	17

EAN/JAN

Resolution	Code type	PCS	Barcode Width*	Quiet Zone	Digits
0.26mm	EAN/JAN	0.9	30mm	10mm	13
0.26mm	EAN/JAN	0.9	22.5mm	10mm	8

* The width includes the quiet zone.

8.2 Scan Area

The scan area is measured from the front edge of the scanner.

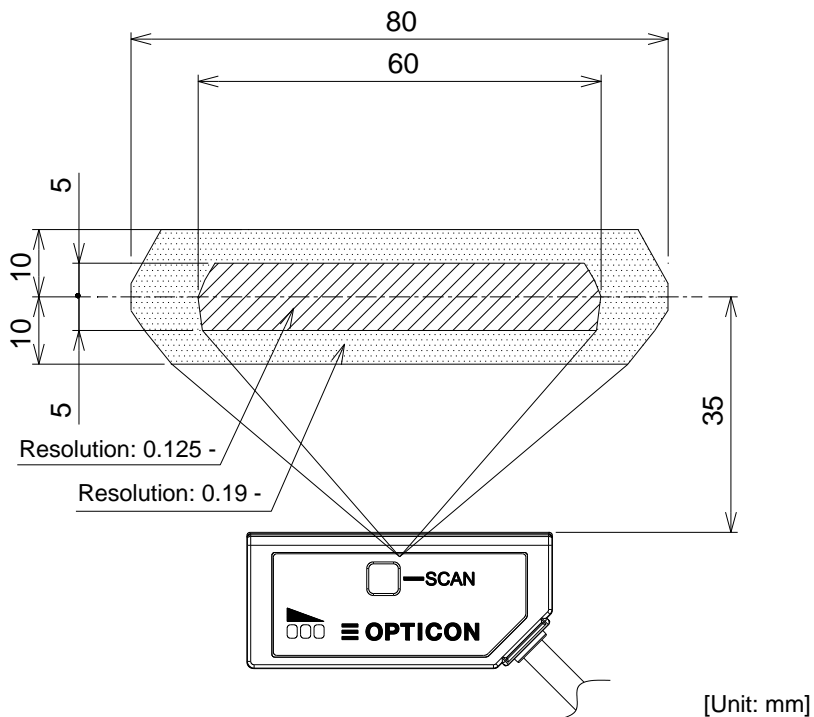

Figure 4: Scan area and resolution

When the barcode print quality or the conditions stated at the beginning of section 8 are not satisfied, the above reading range may not be reached. Please check the readability beforehand and decide appropriate installation conditions.

8.3 Depth of Field

Code Resolution (mm)	Code type	PCS	Depth of Field (mm)	Maximum reading width
0.125 – below 0.19	Code 39	0.9	35±5	60mm
0.19 – 1.08	Code 39	0.9	35±10	80mm

Note: Maximum reading width of the barcode includes the quiet zone.

8.4 Printed Contrast Signal (PCS)

PCS 0.45 or higher

Conditions

MRD	≥ 32% (≥ 80% reflectivity of space and quiet zone)
Distance	35 mm from the front edge of the scanner
Barcode width	Maximum 60mm
Barcode	Code 39. Resolution = 0.2 mm / PCS 0.45, specified in Section 8.1.

MRD = Minimum reflectance of white space – Maximum reflectance of black bar

$$PCS = \frac{\text{Reflectance of white space} - \text{Reflectance of black bar.}}{\text{Reflectance of white space}}$$

Note: Be sure to keep the optical window clean without dirt or scratches, or it may deteriorate the reading performance.

8.5 Minimum Resolution

0.125mm (Code 39 specified in Section 8.1)

Conditions

Bar code	Above code specified in Section 8.1.
Distance	35±5 mm from the front edge of the scanner
Angle	$\alpha = 0^\circ, \beta = + 15^\circ, \gamma = 0^\circ$
Curvature	$R = \infty$

8.6 Barcode Width

80 mm

Conditions

Barcode	Code 39. Resolution = 0.19mm / PCS 0.9, specified in Section 8.1.
Distance	35 mm from the front edge of the scanner
Angle	$\alpha = 0^\circ, \beta = + 15^\circ, \gamma = 0^\circ$
Curvature	$R = \infty$

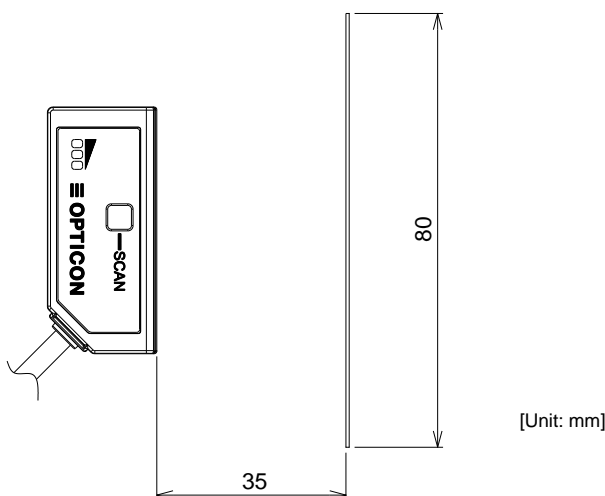

Figure 5: Barcode width

8.7 Pitch, Skew and Tilt

Pitch	$\alpha = \pm 6^\circ$
Skew	$-30^\circ \leq \beta \leq -10^\circ, 10^\circ \leq \beta \leq 30^\circ$
Tilt	$\gamma = \pm 10^\circ$

Conditions

Barcode	EAN/JAN. Resolution = 0.26mm / PCS 0.9 / 13 digits, specified in Section 8.1.	
Distance	35 mm from the front edge of the scanner	
Curvature	R = ∞	
Angle	Pitch	$\beta = +15^\circ, \gamma = 0^\circ$
	Skew, Dead zone	$\alpha = 0^\circ, \gamma = 0^\circ$
	Tilt	$\alpha = 0^\circ, \beta = +15^\circ$

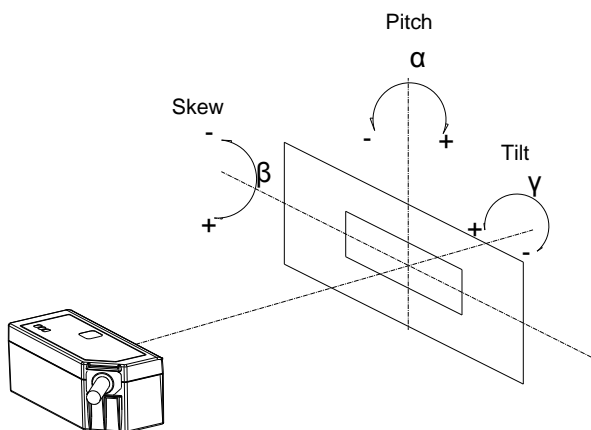

Figure 6: Pitch, Skew and Tilt

8.8 Curvature

0.26 mm 13-digit EAN/JAN	R ≥ 30 mm
0.26 mm 8-digit EAN/JAN	R ≥ 20 mm

Conditions

Barcode Sample	EAN/JAN PCS 0.9 specified in Chapter 8.1
Distance	35 mm from the front edge of the scanner
Angle	$\alpha = 0^\circ, \beta = +15^\circ, \gamma = 0^\circ$

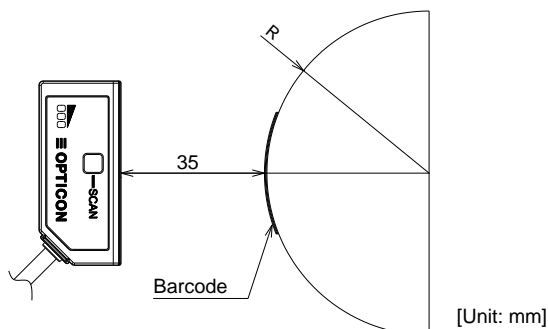

Figure 7: Curvature

8.9 Motion Tolerance

When scanning barcodes that are moving vertically as shown in figure 8, the scanner usually has almost the same performance as when it is reading non moving barcodes. The scanning performance is only reduced when a barcode is moved at very high speed or when the height of the barcode is very small.

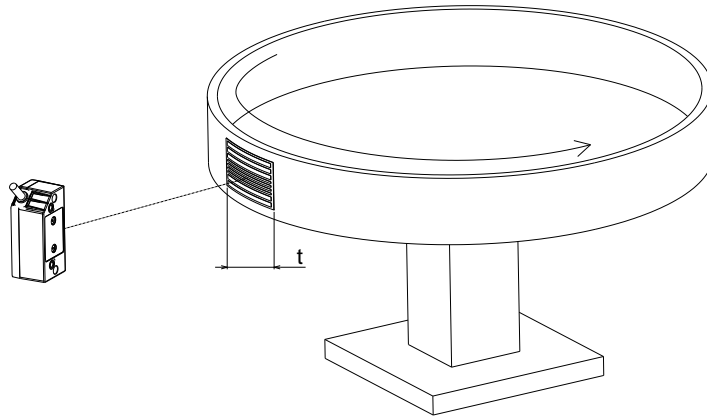

Figure 8: Barcode moving vertically

However, when scanning barcodes that are moving horizontally as shown in figure 9, the scanning performance will be reduced rapidly at increasing speed. Therefore, make sure to stop the barcode for a brief moment when the barcode is aligned at the center of the scanner.

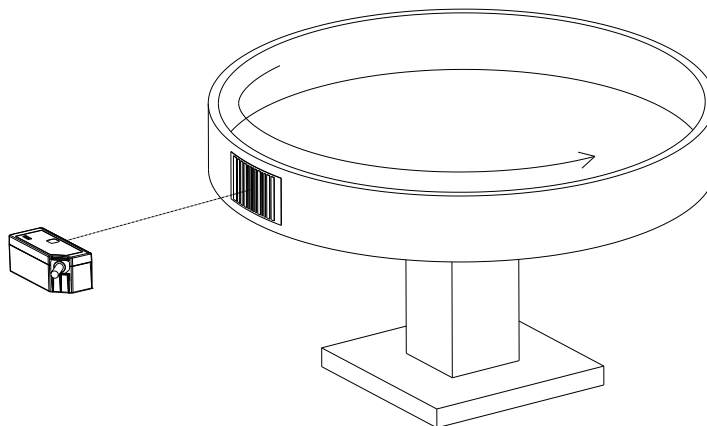

Figure 9: Barcode moving horizontally

Note: When scanning barcodes on moving items as described above, scanning performance may decline rapidly, depending on operating conditions.

9 Interface Specification

The F-100 SR interface is RS-232C (D-sub 9pin), RS-232C (Loose end) or USB (COM/HID).

9.1 RS-232C Interface (D-Sub 9pin)

9.1.1 Initial Communication Settings

Basic communication specs are as follows.

Item	Communication spec	Default setting
Baud rate	150 to 115200 bps	9600 bps
Data length	7 / 8 bits	8 bits
Parity bits	None / Even / Odd parity	None
Stop bits	1 / 2 bit	1 bit

9.1.2 Signal Specification

Signal names are based on the signals transmitted from the scanner to the host.

Signal Level RS-232C communication line

Signal Name	IN/OUT	Voltage(V)	
		Mark	Space
TxD	OUT	-5 to -15	+5 to +15
RxD	IN	-3 to -15	+3 to +15
RTS	OUT	-5 to -15	+5 to +15
CTS	IN	-3 to -15	+3 to +15

9.1.3 Pin Assignment

Signal Name	Pin No.	Note
(NC)	1	Open (not connected)
TxD	2	RS-232C communication line
RxD	3	RS-232C communication line
(NC)	4	Connect to pin 6
GND	5	
(NC)	6	Connect to pin 4
CTS	7	RS-232C communication line
RTS	8	RS-232C communication line
(NC)	9	Open (not connected)

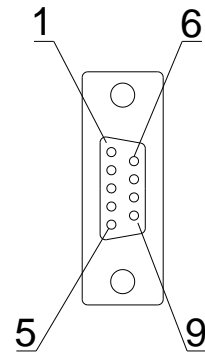

Figure 10: RS-232C D-Sub9pin Connector

9.1.4 RS-232C D-Sub 9pin Circuit

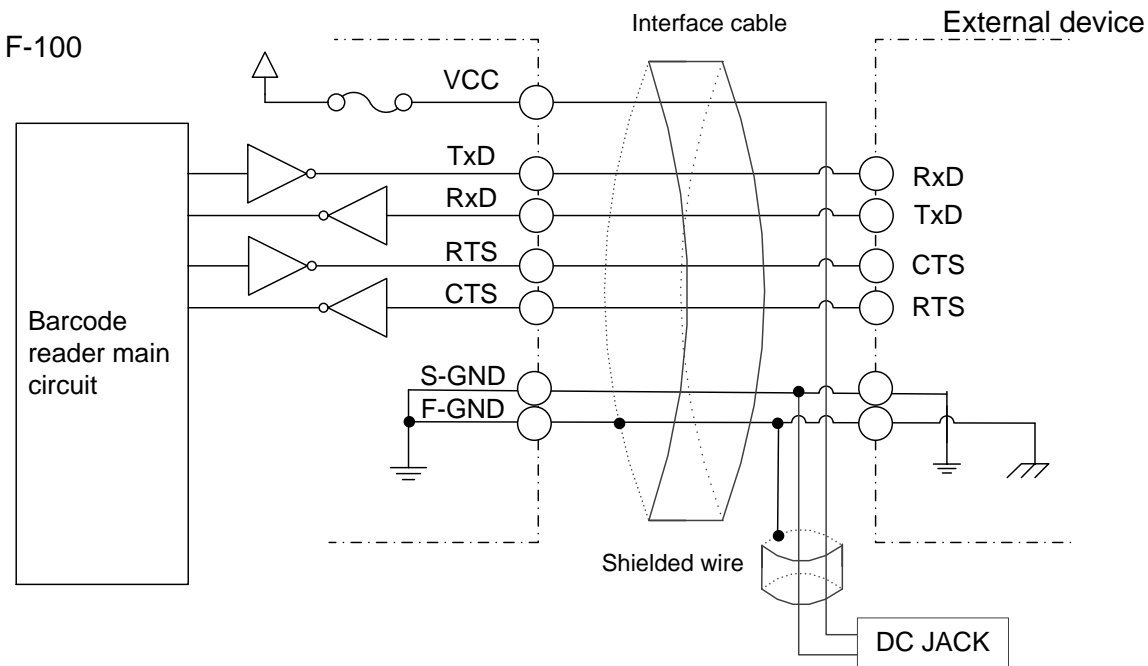

Figure 11: Interface Circuit (RS-232C D-sub 9pin)

9.1.5 RS-232C D-Sub 9pin Interface Cable

Cable length	2000 mm
Wire conductors diameter	AWG28
Cable diameter	φ3.8mm
Weight	Approx. 75g

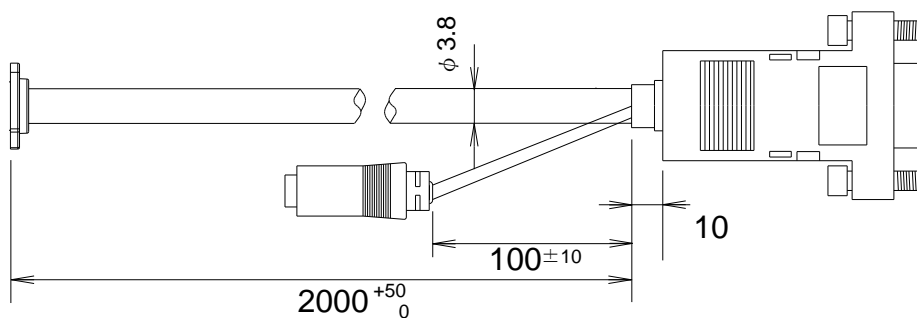

Figure 12: RS-232C D-sub 9pin Interface Cable

9.2 RS-232C Interface (Loose End)

9.2.1 Initial Communication Settings

Basic communication specs are as follows.

Item	Communication spec	Default setting
Baud rate	150 to 115200 bps	9600 bps
Data length	7 / 8 bits	8 bits
Parity bits	None / Even / Odd parity	None
Stop bits	1 / 2 bit	1 bit

9.2.2 Signal Specification

Signal names are based on the signals transmitted from the scanner to the host.

Signal Level Sequencer Signal (loose end only)

Signal Name	IN/OUT	Voltage(V)	
		ON	OFF
Trigger	IN	0V to 1.5V	3.0 V to Vcc
OK	OUT	0.3V/5mA	OC output/24V(max)*
NG	OUT	0.3V/5mA	OC output/24V(max)*

* OC output: Open Collector output

9.2.3 Pin Assignment

Signal Name	Pin No.	Note
TxD	Green	RS-232C communication line
RxD	White	RS-232C communication line
RTS	Gray	RS-232C communication line
CTS	Blue	RS-232C communication line
Trigger	Brown	External trigger input terminal
S-GND	Black	Signal line GND
Vcc	Red	Power-supply (5V)
NG	Orange	NG output terminal
OK	Yellow	OK output terminal
F-GND	Black (tick)	Frame GND (cable shielded wire)

9.2.4 RS-232C Loose End Circuit

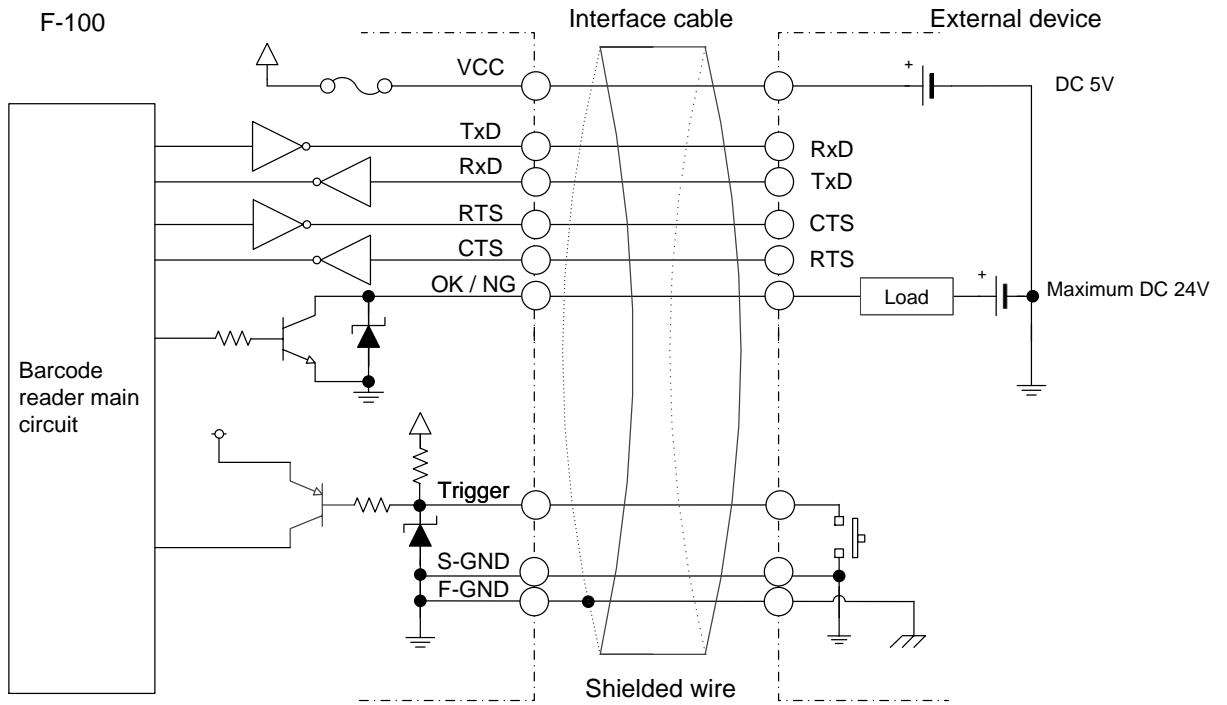

Figure 13: Interface Circuit (RS-232C Loose End)

9.2.5 RS-232C Loose End Interface Cable

Cable length	2000 mm
Wire cable length	60mm
Wire conductors diameter	AWG28
Insulator outer deameter	0.58mm
Wire length	7mm
Cable diameter	φ3.8mm
Weight	Approx. 55g

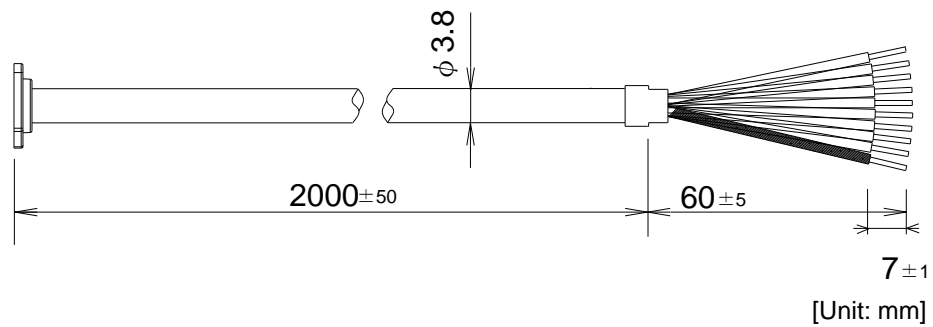

Figure 14: RS-232C Loose End Interface cable

9.3 USB Interface

The USB interface has two specifications: HID (Human Interface Device Class) and COM (Communication Device Class). COM allows for bidirectional serial communication and is used for command transmission from the host device to the scanner in addition to receiving barcode data.

Note:

For the USB-COM interface model, the Opticon USB-COM driver must be installed on your host device. Please use the latest of the USB-COM version driver.

While using USB-COM and the host COM port is not actively open, scan data cannot be sent and F-100 SR will make an error sound.

USB-HID interface model uses OS standard driver. Driver installation is unnecessary in the environments where the HID keyboard operates. F-100 SR can be use just by connecting the USB.

9.3.1 USB Interface Specifications

Bus-power class	500 mA (high-power)
Speed	Full speed (12 Mbps)
Interface	HID/COM (Virtual COM Port)

Note:

The USB interface models are bus powered and no AC adapter is needed.

Do not use the host keyboard when using USB-HID to transmit barcode data. Data may be lost as a result.

Item	Explanation
Transfer Speed	USB2.0 Full Speed
Vendor ID	065A
Product ID (HID)	0001
Product ID (COM)	0009

9.3.2 USB Connector

Pin No.	Signal name
1	VBUS
2	D-
3	D+
4	GND

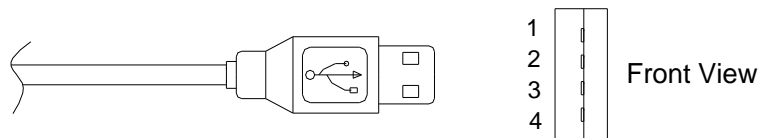

Figure 15: USB Plug (A) Pin Assignment

9.3.3 USB Interface Circuit

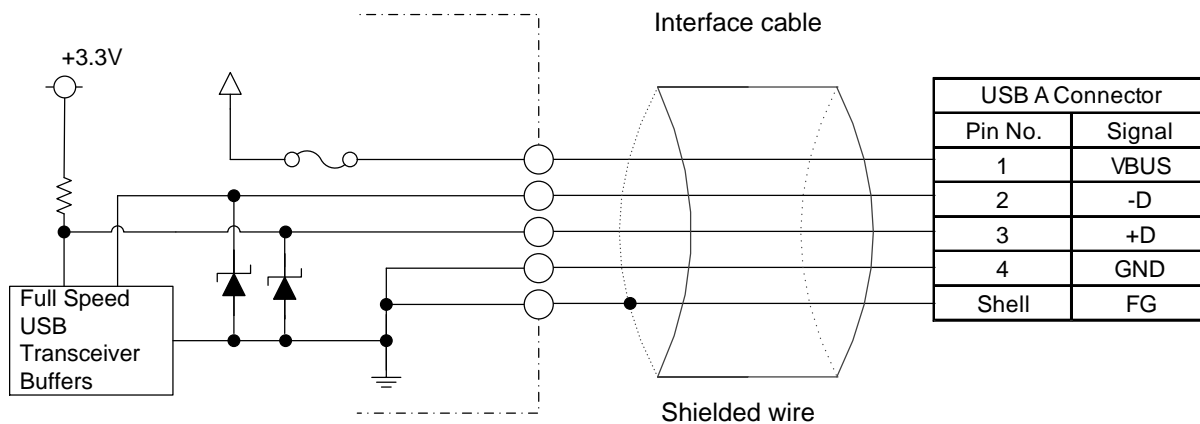

Figure 16: Interface Circuit (USB)

9.3.4 USB Interface Cable

Cable length 2000 mm
Cable diameter $\phi 3.8\text{mm}$
Weight Approx. 60g

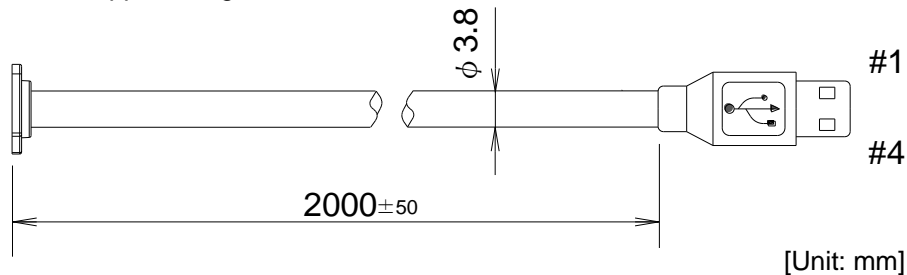

Figure 17: USB Interface Cable

10 Environmental Specifications

10.1 Temperature

Scanning performance is guaranteed when the ambient temperature is within the following ranges:

Operating Temperature	0 to 40 °C
Storage Temperature	-10 to 60 °C

Conditions

Barcode	EAN/JAN-13 Resolution = 0.26 mm / PCS 0.9, specified in chapter 8.1
Distance	35 mm from the front edge of the scanner
Angle	$\alpha = 0^\circ$, $\beta = 15^\circ$, $\gamma = 0^\circ$
Curvature	$R = \infty$

10.2 Humidity

Scanning performance is guaranteed when the ambient humidity is within the following ranges:

Operating Humidity	20 to 85%RH (no condensation, no frost)
Storage Humidity	20 to 90%RH (no condensation, no frost)

Conditions

Barcode	EAN/JAN-13 Resolution = 0.26 mm / PCS 0.9 Specified in chapter 8.1
Distance	35 mm from the front edge of the scanner
Angle	$\alpha = 0^\circ$, $\beta = 15^\circ$, $\gamma = 0^\circ$
Curvature	$R = \infty$

10.3 Ambient Light Immunity

Scanning performance is guaranteed when the illumination on a barcode surface is between zero and the following values:

Incandescent light	5,000 lx
Fluorescent light	5,000 lx
Sunlight	10,000 lx

Conditions

Barcode	EAN/JAN-13 Resolution 0.26 mm / PCS 0.9 specified in chapter 8.1
Distance	35 mm from the front edge of the scanner
Illuminance	Illuminance is uniform on the barcode surface.
Angle	$\alpha = 0^\circ, \beta = +15^\circ, \gamma = 0^\circ$
Curvature	$R = \infty$

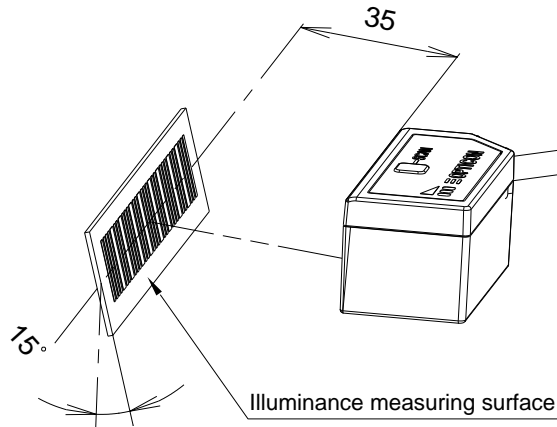

Figure 18: Ambient Light Immunity

Note:

Avoid direct or specular reflection from the light source to get the best scanning performance. When the illuminance is not uniform on the barcode surface, the scanner may fail to read.

10.4 Dust and Drip Proof

IEC IP42 equivalent

Protection against solid objects: Level 4 equivalent

Protected against solid objects greater than 1.0 mm

Protection against liquids: Level 2 (JIS IPX2)* equivalent

Protected against dripping water from the vertical when tilted up to 15°

* () is JIS drip-proof type.

10.5 Scan Key Durability

Activating the scanner by pressing the trigger shall be possible after the following scan key strength test.

Scan Key Strength Test: Affix the scanner as shown in the following picture. Press and release the scan key by a push rod with a diameter of 10mm with a force of 9.8N (1kgf) and repeat this 5 million times.

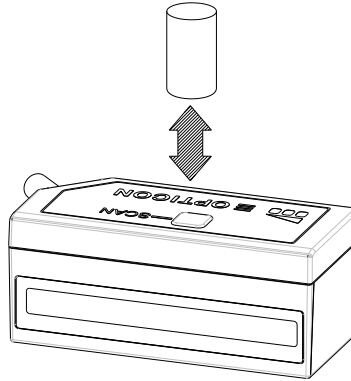

Figure 19: Scan key durability

10.6 Cable Strength

There shall be no malfunction after the following cable strength test.

Cable Strength Test: Affix the scanner to an immovable object and pull the cable using a force of 24.5N (2.5 kgf static loading) for 60 seconds.

10.7 Cable Bending Strength

There shall be no malfunction after the following cable bending test.

Cable Bending Test: Add a load of 4.9 N (500 gf) to the cable and flex it 60° in both directions. Repeat this 700 times.

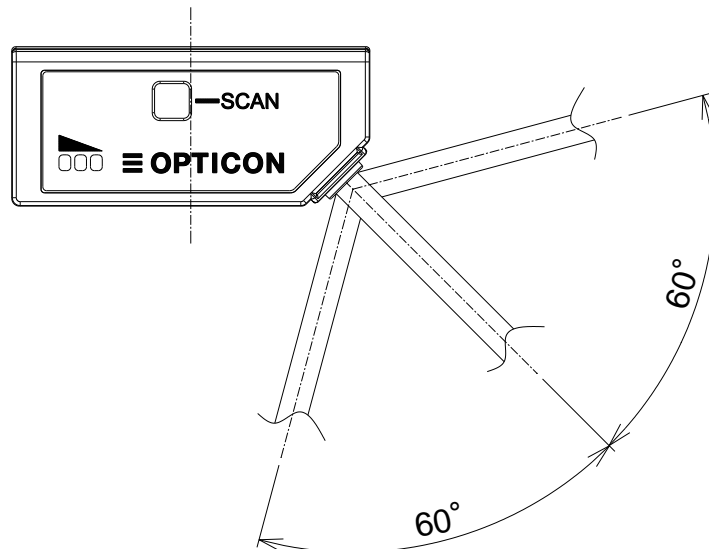

Figure 20: Cable Bending Strength

10.8 Vibration Strength (without packing)

There shall be no malfunction after the following vibration test.

Vibration test: Increase the frequency of the vibration from 10Hz to 100Hz at an acceleration velocity of 19.6m/s^2 (2.0 G) for 30 minutes in the non-operating state. Repeat this twice for each of X, Y and Z direction.

10.9 Vibration Strength (in individual packing)

There shall be no malfunction after the following vibration test.

Vibration test: Increase the frequency of the vibration from 10Hz to 100Hz at an acceleration velocity of 19.6m/s^2 (2.0 G) for 30 minutes in individually packaged state. Repeat this twice for each of X, Y and Z direction.

10.10 Drop Impact Strength (without packaging)

There shall be no malfunction after the following drop test.

Drop test: Drop the scanner 18 times (3 times at each of 6 orientations), from a height of 60 cm onto a concrete floor.

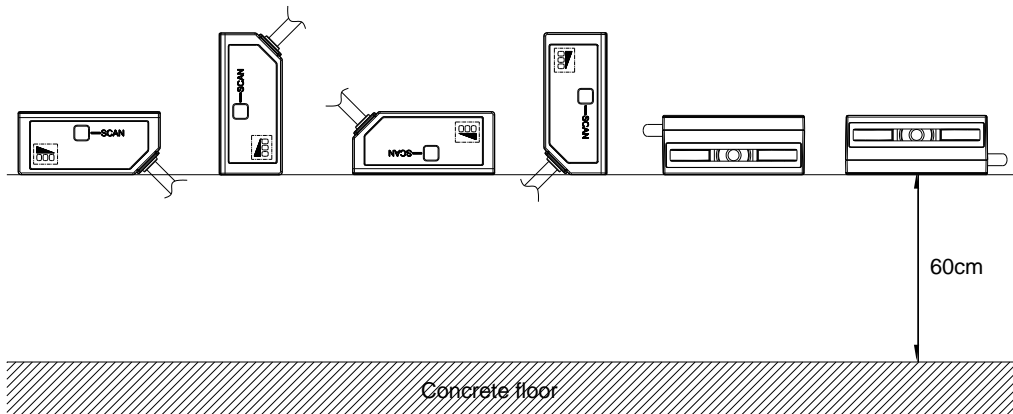

Figure 21: Drop Impact Strength

10.11 Drop Impact Strength (in individual packaging)

There shall be no sign of malfunction after the following drop test.

Drop test: Drop an individually packaged scanner 10 times in total, at any of 1 corner, 3 edges, and 6 faces, from a height of 150 cm onto a concrete floor.

10.12 Electrical Specifications

Electrostatic discharge* immunity*	No destruction	±15 kV (air discharge, direct)
	No malfunction	±8 kV (air discharge, direct)
		±6 kV (contact discharge, direct / indirect)

* Testing method is compliant with IEC-61000-4-2. (150 pf, 330 ohm)

11 Regulatory Compliance

11.1 LED Safety

IEC 62471:2006 Exempt Risk Group

11.2 Product Safety

UL 60950-1, 2nd Edition, 2014-10-14

CAN/CSA C22.2 No. 60950-1-07, 2nd Edition, 2014-10

11.3 EMC

EN 55032:2012

EN 55024:2010

FCC Part 15 Subpart B Class B

This device complies with part 15 of the FCC Rules. Operation is subject to the following two conditions: (1) this device may not cause harmful Interference, and (2) this device must accept any interference received, including interference that may cause undesired operation.

VCCI-CISPR 32:2016 クラス B

この装置は、クラスB機器です。この装置は、住宅環境で使用することを目的としていますが、この装置がラジオやテレビジョン受信機に近接して使用されると、受信障害を引き起こすことがあります。

取扱説明書に従って正しい取り扱いをして下さい。

V C C I - B

12 RoHS

RoHS directive

RoHS: The restriction of the use of certain hazardous substances in electrical and electronic equipment.

Directive 2011/65/EU

Commission Delegated Directive (EU) 2015/863

13 Reliability

MTBF (Mean Time Between Failures) 50,000 hours

Note: This is calculated based on standard operation of the product within the operating environment parameters and without extreme electronic or mechanical shock.

14 Precautions

Read following caution carefully before installing and/or using this product. Incorrect handling may cause malfunction, overheating, smoke, fire, injury and electric shock etc.

 Caution
<p>Electrical handling</p> <ul style="list-style-type: none"> • In case any abnormality occurs in the scanner or stops working, unplug the cable and the AC adapter and contact the dealer. Leaving as is may cause malfunction, overheating, smoke and fire. • Do not use this product at voltage outside the specified range. It may cause overheating, smoke and fire. • Do not wet the AC adapter with water. It may cause overheating, smoke, fire and electric shock. • Do not plug/unplug the connectors while power is supplied.
<p>Excessive shock / stress</p> <ul style="list-style-type: none"> • Do not drop this product. • Do not push or place this product under or between heavy items. • Do not swing the product around by the cable. It may cause injury or damage to the device.
<p>Cable handling</p> <ul style="list-style-type: none"> • In case the cable sheath breaks or torn, core wire expose due to this, or breakage occurs at the root of the bellows, or even if there is no abnormality in the appearance but cable generates heat, unplug the cable and the AC adapter and contact the dealer. Using it as is may cause malfunction, overheating and fire. • Do not wrap F-100 cable around a host device (PC, tablet etc.). It may cause breakage to the bellows part and the cable sheath, and also cause malfunction, overheating, smoke and fire. • Do not place this product and AC adapter under or between heavy items. • Do not bend the cable at extremely low temperatures.
<p>Operating environment</p> <ul style="list-style-type: none"> • Do not use this product at temperatures outside the specified range. • Do not use this product near combustible materials (gas, gunpowder etc.). It may cause smoke and fire. • Do not immerse this product in water or any other liquid. • If perchance condensation formed on the product, abstain from the use of it until moisture has evaporated to prevent malfunctions. • Do not store this product in dusty environments and in extremely high humidity. • Do not store this product in extremely cold or hot places. Also avoid exposure to direct sunlight for long periods of time. • Avoid static electricity and do not put the product near a radio or a TV. Excessive static electricity may cause malfunction. • Do not place in an unstable place.
<p>Others</p> <ul style="list-style-type: none"> • Do not disassemble this product. • Do not stare into the LED light from the scan window. It may damage your eyes. • Do not expose this product to edible / industrial fat and chemicals. • This product may be affected by a momentary voltage fluctuation caused by lightning. • Do not let children use this product.

 **Caution**

Power supply and wiring

- This product is intended to be supplied by a Listed Power Unit marked "Class 2" or "LPS".
- Do not connect power supply or AC power supply that is outside of the rated supply voltage range ($5V \pm 5\%$ / 0.5A min).
- Be sure to turn the power OFF before connecting or disconnecting a cable. Connecting or disconnecting a cable while the power is ON may cause failure.
- Incorrect wiring may cause damage to internal circuit. Please be careful when connecting. Do not short-circuit the load with the OK/NG signal.
- Connect different wires for high-voltage wire, power line and this product. Avoid same wiring and parallel wiring by the same duct, as it may cause malfunction or damage due to the influence of induced noise.

15 Product Display

15.1 Product Label

Example of label attached to the scanner is shown below. Serial number is 6 digits from 000001. Refer 17.3 (Mechanical Drawing) for the allocation.



Figure 22: Product Label

15.2 UL Label

Example of UL label attached to the scanner is shown below. Refer 17.3 (Mechanical Drawing) for the allocation.

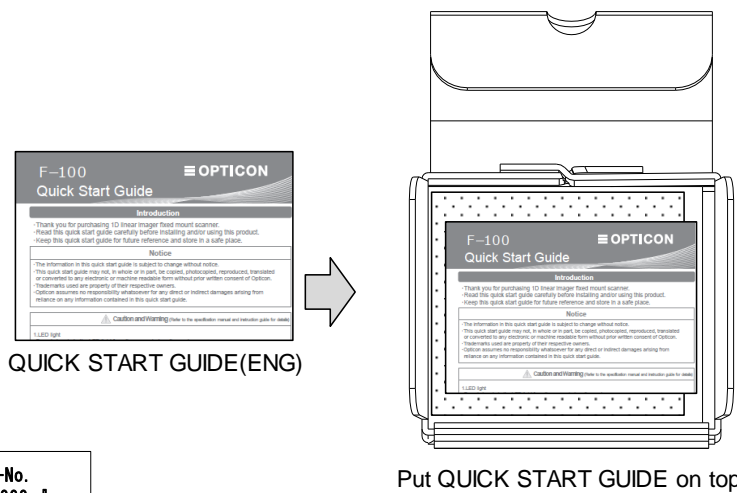
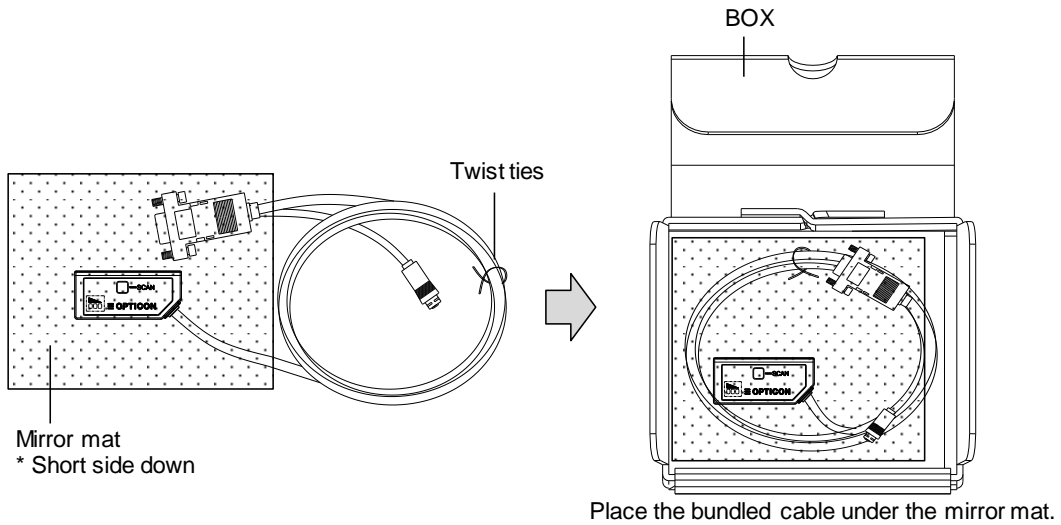

Figure 23: UL Label

16 Packaging Specifications

16.1 Individual Packaging Specification (RS-232C)

Package size Approx. 122 x 112 x 38 (WDH mm)
Weight Approx. 105 g (RS-232C model)



Display for the serial-No.
From 『 000001 』 to 『 999999 』
Same number as the scanner.
Number of six digits.
*Continuous Number.

BAR CODE LABEL for BOX

Model No.	MADE IN JAPAN
F-100 SR-RS232C	
Spec#JPN *OF1F100B*	Spec#EUR *14271*
Spec#USA *F100SRR1-063*	Quantity 1
Serial No. *XXXXX*	Ro CE

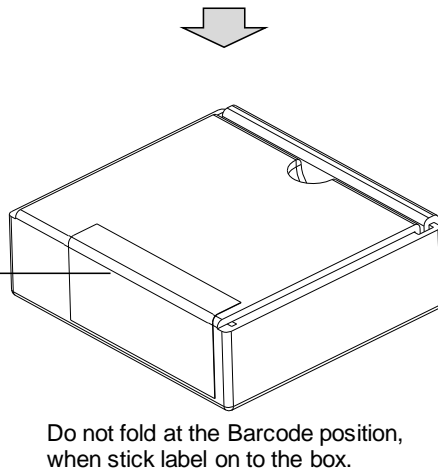
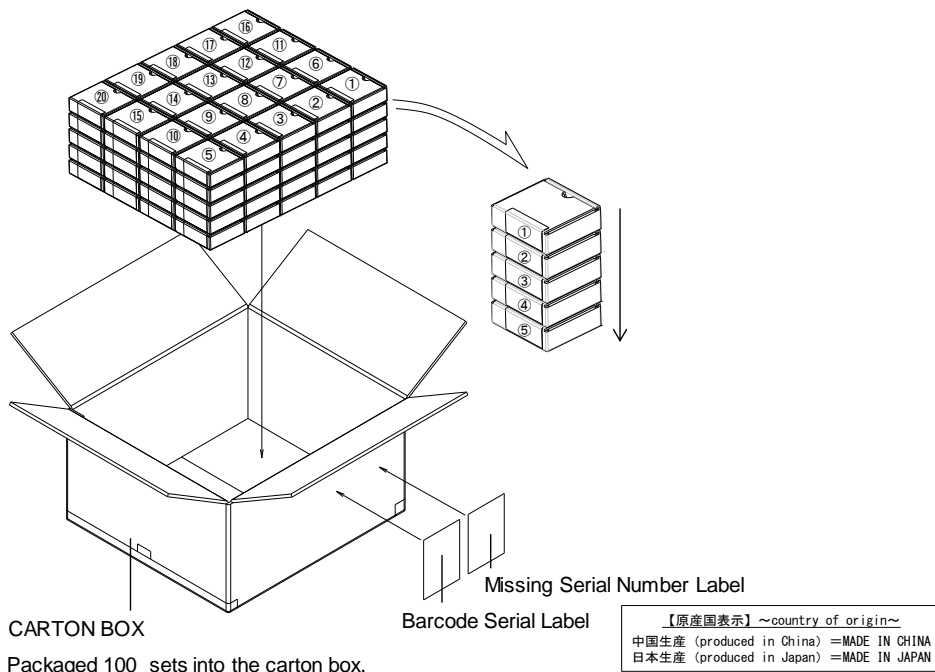

Figure 24: Individual Packaging (RS-232C)

16.2 Collective Packaging Specification

Assembled package size Approx. 588 × 514 × 285 (WDH mm)
 Weight Approx. 14 kg (RS-232C model)
 Approx. 12.5 kg (USB model)



Barcode Serial Label for Packaging Box:
 Stick the labels on both front and back side of the box.

OSE C/No. △△
MADE IN JAPAN

Product **F-100 SR-RS232C**

PO# *△△△△△△△△△△*

Spec#JPN *OF1 F1 00B*

Spec#EUR *14271*

Spec#USA *F100SRR1-063*

Q'ty *XXX* S/N(from) *XXXXXX*

XXX / XXXX S/N(to) *XXXXXX*

Missing Serial Number	Missing Q'ty	2
1	*XXXXXX*	
2	*XXXXXX*	

ROM-Ver △△△△△

Shipping Date 20 △△/△△/△△

OPTOELECTRONICS CO.,LTD

Missing Serial Number Label:
 Attach this label when there are more than 3 labels of which serial numbers are out of order (not in a correct sequence).

OSE C/No. △△
MADE IN JAPAN

Missing Serial Number	Missing Q'ty	XX
3	*XXXXXX*	
4	*XXXXXX*	
5	*XXXXXX*	
6	*XXXXXX*	
7	*XXXXXX*	
8	*XXXXXX*	
9	*XXXXXX*	
10	*XXXXXX*	
11	*XXXXXX*	
12	*XXXXXX*	

OPTOELECTRONICS CO.,LTD

'Ro mark' on the trays and boxes indicates that the product is RoHS compliant as is declared by OPTOELECTRONICS Co., Ltd

Figure 25: Collective Packaging

Note: The above drawing shows the collective packing example of a RS-232C model.

17 Physical Features

17.1 Dimensions

Approx. 45.5 (W) x20.25 (D) x19 (H) (mm, except protruding portion)

17.2 Weight

Approx. 15 g (excluding cable)

17.3 Mechanical Drawing

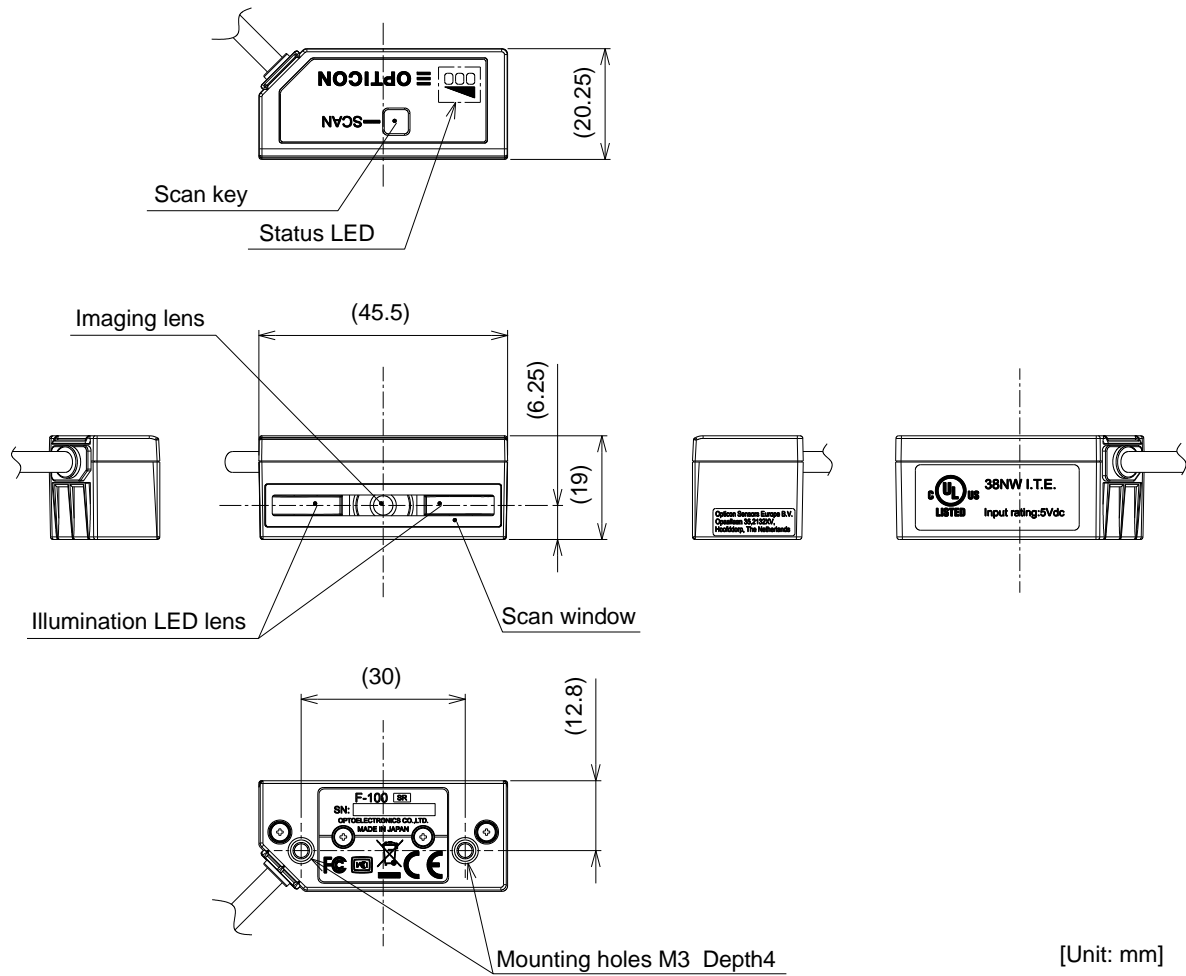

Figure 26: Mechanical Drawing

18.2 Default Setting (Part 2: Read Options, Illumination LED, Trigger, Buzzer)

Item	Default
Setting the number of characters	Fixed length OFF all codes
Read mode	Single read
Multiple read reset time	500 msec
Add-on wait mode	500 msec
Redundancy ^{*1}	Read 1 times, redundancy = 0
Multiple columns read	Disable multiple columns read
Read time	2seconds
Trigger input	Enable
Buzzer durations	50msec
Buzzer tone	3.0kHz
Buzzer loudness	Loud (maximum)
Indicator duration (Green LED)	200msec

(*1) In case of the following symbologies, because of the prevention of miss-decoding, the reading times are increased once and redundancy is also increased once.

Symbology	Length
Code 39	5 or less
Codabar / NW-7	All
IATA	8 or less
Industrial 2 of 5	8 or less
Interleaved 2 of 5	8 or less
MSI/Plessey	4 or less
Code 11	5 or less
TELEPEN	8 or less
S-code	7 or less
Matrix 2 of 5	8 or less
Chinese Post Matrix 2 of 5	8 or less
Code 128	2 or less

18.3 Default Setting (Part 3: Communication Settings)

18.3.1 RS-232C

Item	Default
Baud rate	9600 bps
Parity bit	None
Data bit	8 bits
Stop bit	1 bit
Handshaking	No
ACK / NAK	No
CTS time out	Indefinitely
ACK / NAK time out	1 sec
Command header	ESC
Command terminator	CR
Response to command	Disable

18.3.2 USB

Item	Default
USB-COM	CDC-ACM compliant (USB-COM)*

* The Opticon USB-COM driver must be installed on your host to use in USB-COM. Please contact sales offices for the manual and setting tools.