

NLV-1001



The NLV 1001 is a compact fixed-position laser barcode scanner, using short-wavelength red laser beam.

Specifications Manual

All information subject to change without notice.

Document History

Model Number:	NLV 1001	Specification Number:	SS06037
Edition:	5B	Original Spec Number:	SS06079
Date:	2026-02-12		

Copyright 2026 Opticon. All rights reserved.

This manual may not, in whole or in part, be copied, photocopied, reproduced, translated or converted to any electronic or machine readable form without prior written consent of Opticon.

Limited Warranty and Disclaimers

PLEASE READ THIS MANUAL CAREFULLY BEFORE INSTALLING OR USING THE PRODUCT.

Serial Number

A serial number appears on all Opticon products. This official registration number is directly related to the device purchased. Do not remove the serial number from your Opticon device. Removing the serial number voids the warranty.

Warranty

Unless otherwise agreed in a written contract, all Opticon products are warranted against defects in materials and workmanship for two years after purchase. Opticon will repair or, at its option, replace products that are defective in materials or workmanship with proper use during the warranty period. Opticon is not liable for damages caused by modifications made by a customer. In such cases, standard repair charges will apply. If a product is returned under warranty and no defect is found, standard repair charges will apply. Opticon assumes no liability for any direct, indirect, consequential or incidental damages arising out of use or inability to use both the hardware and software, even if Opticon has been informed about the possibility of such damages.

Packaging

The packing materials are recyclable. We recommend that you save all packing material to use should you need to transport your scanner or send it for service. Damage caused by improper packaging during shipment is not covered by the warranty.

Trademarks

Trademarks used are the property of their respective owners.

Opticon Inc. and Opticon Sensors Europe B.V. are wholly owned subsidiaries of OPTOELECTRONICS Co., Ltd., 12-17, Tsukagoshi 4-chome, Warabi-shi, Saitama, Japan 335-0002. TEL +81-(0) 48-446-1183; FAX +81-(0) 48-446-1184

SUPPORT

USA

Phone: 800-636-0090

Email: support@opticonusa.com

Web: www.opticonusa.com

Europe

Email: support@opticon.com

Web: www.opticon.com

Contents

1	ABSTRACT	6
2	OVERVIEW	6
3	PHYSICAL FEATURES	7
3.1	DIMENSIONS	7
3.2	WEIGHT.....	7
4	ENVIRONMENTAL SPECIFICATIONS	7
4.1	OPERATING TEMPERATURE AND HUMIDITY	7
4.2	STORAGE TEMPERATURE AND HUMIDITY.....	7
4.3	AMBIENT LIGHT IMMUNITY	7
5	ELECTRICAL SPECIFICATIONS	8
5.1	ABSOLUTE MAXIMUM RATINGS	8
5.2	RECOMMENDED OPERATING CONDITIONS.....	8
5.3	ELECTRICAL CHARACTERISTICS	8
6	OPTICAL SPECIFICATIONS	9
6.1	LASER SCAN SPECIFICATIONS	9
7	TECHNICAL SPECIFICATIONS	9
7.1	PRINT CONTRAST SIGNAL (PCS).....	9
7.2	MINIMUM RESOLUTION.....	9
7.3	SCAN AREA AND RESOLUTION	10
7.3.1	<i>Depth of Field</i>	10
7.4	PITCH, SKEW, AND TILT	11
7.4.1	<i>Pitch Angle</i>	11
7.4.2	<i>Skew Angle and Dead Zone</i>	12
7.4.3	<i>Tilt Angle</i>	13
7.5	CURVATURE	14
8	INTERFACE SPECIFICATIONS	14
8.1	RS-232C INTERFACE SPEC.....	14
8.1.1	<i>Settings and Communication</i>	14
8.1.2	<i>Signal Level</i>	15
8.1.3	<i>Interface Circuit</i>	15
8.1.4	<i>Character Format</i>	16
8.1.5	<i>Communication Format</i>	16
8.1.6	<i>Handshaking</i>	16
8.1.6.1	No Handshake.....	16
8.1.6.2	BUSY/READY	17
8.1.6.3	MODEM	19
8.1.6.4	ACK/NAK	20
8.1.6.5	ACK/NAK—NO RESPONSE.....	21
8.1.7	<i>OK/NG Signal Output Timing</i>	22
8.1.7.1	Good Read (Synchronous).....	22
8.1.7.2	Read Error within Specified Time (Synchronous)	22
8.1.7.3	Good Read (One Shot)	23
8.1.7.4	Read Error within Specified Time (One Shot)	23
8.2	USB INTERFACE SPECIFICATIONS	23
8.2.1	<i>Interface</i>	23
8.2.2	<i>Interface Circuit</i>	23
9	CABLE AND CONNECTOR	24

9.1	RS-232C CABLE.....	24
9.1.1	(Standard Specification).....	24
9.1.2	D-sub Specification.....	24
9.1.3	Connector Pin-outs.....	25
9.1.3.1	Standard Specification.....	25
9.1.3.2	D-sub Specification.....	25
9.2	USB CABLE.....	26
9.2.1	Connector.....	27
	USB "A" Connector.....	27
9.2.2	Connector Pin-outs.....	27
9.3	CONNECTOR SPECIFICATION (SCANNER SIDE).....	27
10	DEFAULT SETTINGS.....	28
10.1	SET DEFAULT INTERFACE.....	28
10.2	DEFAULT SETTINGS 1: READABLE CODES.....	29
10.3	DEFAULT SETTINGS 2: READ OPTIONS, TRIGGER, BUZZER.....	30
11	SERIAL NUMBER AND LABELING.....	31
11.1	SERIAL NUMBER.....	31
12	PACKAGING SPECIFICATIONS.....	32
12.1	INDIVIDUAL PACKAGING SPECIFICATION.....	32
12.2	COLLECTIVE PACKAGING SPECIFICATION.....	32
13	DURABILITY.....	33
13.1	ELECTRICAL NOISE.....	33
13.2	STATIC ELECTRICITY.....	33
13.3	SHOCK.....	33
13.3.1	Drop Test (without packaging).....	33
13.4	VIBRATION STRENGTH.....	33
13.5	DUST AND DRIP PROOF.....	34
14	RELIABILITY.....	34
15	TRIGGER AND READ OPTIONS.....	34
15.1	AUTO TRIGGER SENSOR.....	34
15.2	AUTO TRIGGER ENABLE/DISABLE SETTINGS.....	35
16	REGULATORY COMPLIANCE.....	36
17	SAFETY.....	36
17.1	SHOCK.....	36
17.2	TEMPERATURE CONDITIONS.....	36
17.3	FOREIGN MATERIALS.....	36
17.4	OTHER.....	36
18	MECHANICAL DRAWING.....	37

Table of Figures

Figure 1: Scan area and resolution	10
Figure 2: Pitch.....	11
Figure 3: Skew angle and dead zone	12
Figure 4: Tilt angle	13
Figure 5: Curvature.....	14
Figure 6: Interface circuit	15
Figure 7: Character format (same for both sending and receiving).....	16
Figure 8: Communication format	16
Figure 9: No handshaking	16
Figure 10: Busy/Ready communication.....	17
Figure 11: Cannot receive command	18
Figure 12: Signal timing	18
Figure 13: Handshaking—modem.....	19
Figure 14: Handshaking—ACK/NAK.....	20
Figure 15: Handshaking—ACK/NAK, no response	21
Figure 16: Good read (synchronous).....	22
Figure 17: Read error (synchronous)	22
Figure 18: Good read (one shot)	23
Figure 19: Read error (one shot)	23
Figure 20: Interface circuit	23
Figure 21: RS-232C cable (standard).....	24
Figure 22: RS-232C cable (D-sub).....	24
Figure 23: 9-pin D sub female connector (with power stereo jack)	25
Figure 24: USB cable.....	26
Figure 25: USB "A" connector	27
Figure 29: Serial number diagram	31
Figure 31: Packaging the NLV 1001.....	32
Figure 32: Auto trigger detection area	35
Figure 33: Mechanical drawing.....	37

1 Abstract

This manual provides specifications for the NLV 1001 compact fixed-position laser barcode scanner.

2 Overview

The NLV 1001 is a fixed-position laser barcode scanner.

The scanning width at the closest point of scanning is 44 mm, and the effective scan angle is 44°.

The use of short-wavelength red laser beams enhances the visibility of scanning lines.

The decoded text of barcode images is output through RS-232C or USB interfaces based on the specification.

Supported symbologies:

Linear (1D)	Postal
JAN/UPC/EAN, incl. add-on	Chinese Post
Codabar/NW-7	Korean Postal Authority code
Code 11	
Code 39	
Code 93	
Code 128	
GS1-128 (EAN-128)	
IATA	
Industrial 2of5	
Interleaved 2of5	
ISBN-ISMN-ISSN	
Matrix 2of5	
MSI/Plessey	
GS1-Databar (RSS)	
S-Code	
Telepen	
Tri-Optic	
UK/Plessey	

3 Physical Features

3.1 Dimensions

W 30.0 X D 43.3 X H 20.0 mm

3.2 Weight

18.5 g max (excluding cable)

4 Environmental Specifications

4.1 Operating Temperature and Humidity

Temperature: -10 to +45 °C

Humidity: 20% to 85% RH

4.2 Storage Temperature and Humidity

Temperature: -20 to +60°C

Humidity: 20% to 90% RH

4.3 Ambient Light Immunity

Decoding performance is guaranteed when the range of illumination on a barcode surface is between zero and the following values:

Incandescent Light	to 3000 lx
Fluorescent Light	to 3000 lx
Sunlight	to 50,000 lx

Conditions

Barcode Sample: OPTOELECTRONICS Test Sample

PCS:	0.9
Resolution:	0.25 mm
Symbology:	9-digit Code 39
Quiet zone:	10 mm
N/W ratio:	1:2.5
Distance:	150 mm
Angle (see note below):	$\alpha = 0^\circ \beta = 15^\circ \gamma = 0^\circ$
Curvature:	$R = \infty$
Power supply voltage:	5.0 V

Direct light or specular reflection from a light source should be prevented from entering the acceptance area.

Note: α , β and γ respectively represent pitch, skew and tilt. Please see section 0 for how these values are defined.

5 Electrical Specifications

5.1 Absolute Maximum Ratings

Parameter	Symbol	Value	Unit
Power supply voltage (V_{CC} to GND)	V_{DD}	-0.5 to 6.5	V
Input voltage	V_{IN}	-0.5 to $V_{CC}+0.5$	V
Power ripple		0.1Vp-p Max. (10–100 kHz)	V
Storage temperature	TSTG	-20 to 60	°C

5.2 Recommended Operating Conditions

Item	Symbol	Condition	Min	Typ	Max	Unit
Power supply voltage	V_{DD}		4.5	5.0	5.5	V
Operating temperature	T_a	Non-condensing Non-freezing	0	-	45	°C
Input voltage	V_{in}		0	—	V_{DD}	V
Output voltage	V_{out}		0	—	V_{DD}	V

5.3 Electrical Characteristics

$V_{CC} = 5V$ $T_a = 25^\circ C$					
Parameter	Symbol	Min	Typ	Max	Unit
Operating current	I_{OP}	-	85	150	mA
Rush current peak	I_{PEEK}	-	400	1500	mA
Standby current	I_{PRE}	-	35	70	mA
Startup time	T_D	-	100	-	ms

Conditions:

- Connect 1Ω resistance to a power supply line in series and measure the current by the voltage between both ends of resistance.
- Power supply voltage is measured at a connector terminal area.
- The current value depends on the interface type and host computer to which the device is connected.

6 Optical Specifications

6.1 Laser Scan Specifications

Parameter	Specification	Unit
Light emitting diode	Red laser diode	-
Wavelength	650 ± 10	nm
Output power	< 1.0	mW
Scanning method	Bi-directional	-
Scanning rate	100 ± 20	scans/s
Scanning angle	54 ± 5	°
Effective scanning angle	44 (Min)	°

7 Technical Specifications

The conditions for technical specifications are as follows, unless otherwise specified in each section.

Conditions

Ambient temperature and humidity:	Room temperature (5 to 35° C) Room humidity (45% to 85% RH)
Ambient light:	500 to 900 lx
Background:	Barcode = black Space = white Margin = white Background of label = black
Power supply voltage:	5.0 V
Decoding test:	0.5 seconds or less for each decoding. Repeat this 10 times.

7.1 Print Contrast Signal (PCS)

0.45 or higher (over 70% of reflectivity of space and quiet zone).

$$PCS = \frac{\text{Reflectance of white bar} - \text{Reflectance of black bar}}{\text{Reflectance of white bar}}$$

Scanning performance may decline if dirt or scratches mar the optical window. Keep the optical window clean.

7.2 Minimum Resolution

0.127 mm

7.3 Scan Area and Resolution

7.3.1 Depth of Field

The depth of field is measured from the edge of the scanner. The scanning range is within the circular arc centered on the scan origin.

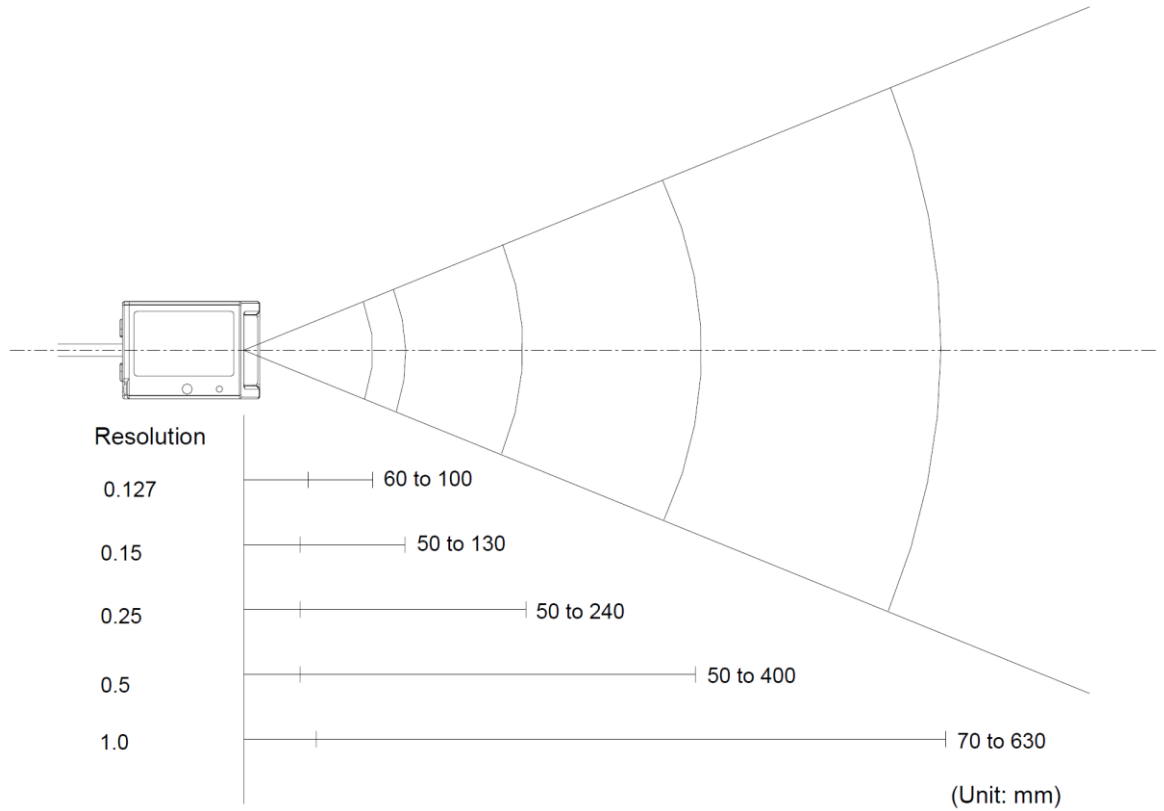

Figure 1: Scan area and resolution

Symbology	Resolution (mm)	Decode Depth (mm)	PCS
Code 39	1.0	70–630	0.9
Code 39	0.5	50–400	0.9
Code 39	0.25	50–240	0.9
Code 39	0.15	50–130	0.9
Code 39	0.127	60–100	0.9

Conditions:

Barcode Sample: OPTOELECTRONICS Test Sample

N/W Ratio: 1:2.5
 Angle: $\alpha = 0^\circ, \beta = 15^\circ, \gamma = 0^\circ$
 Curvature: $R = \infty$

Resolution	Symbology	PCS	Quiet Zone	Digit
1.0 mm	Code 39	0.9	25 mm	1
0.5 mm	Code 39	0.9	18 mm	3
0.25 mm	Code 39	0.9	10 mm	8
0.15 mm	Code 39	0.9	7 mm	10
0.127 mm	Code 39	0.9	5 mm	4

7.4 Pitch, Skew, and Tilt

7.4.1 Pitch Angle

$\alpha = \pm 35^\circ$

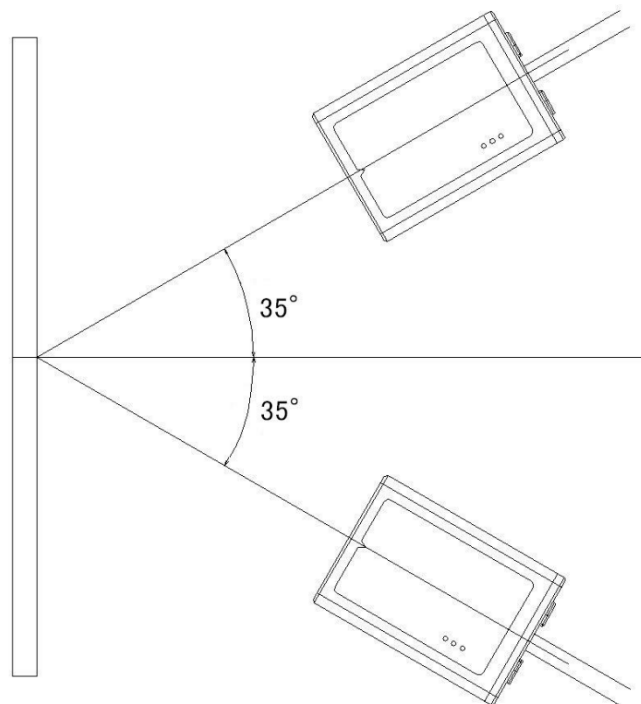

Figure 2: Pitch

7.4.2 Skew Angle and Dead Zone

Skew angle: $\beta = \pm 50^\circ$ (Excluding dead zone)

Dead zone: $\beta = \pm 8^\circ$ (Areas in which decoding fails due to specular reflection)

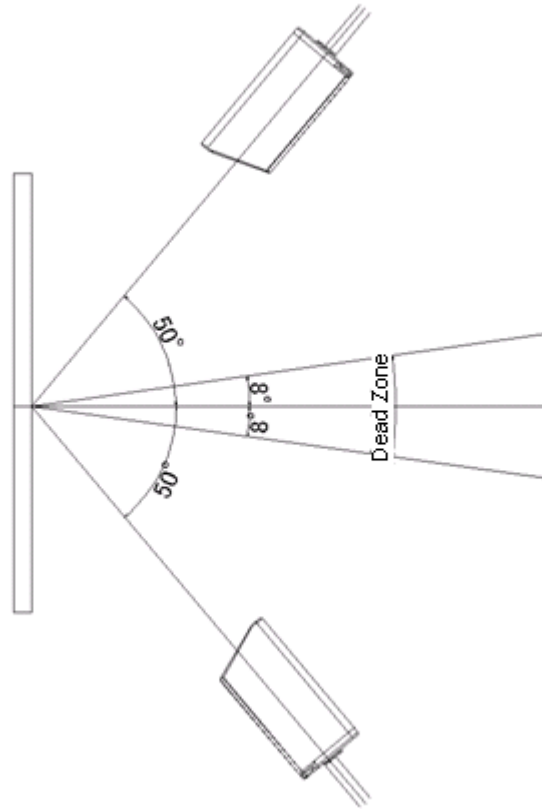

Figure 3: Skew angle and dead zone

7.4.3 Tilt Angle

$$\gamma = \pm 20^\circ$$

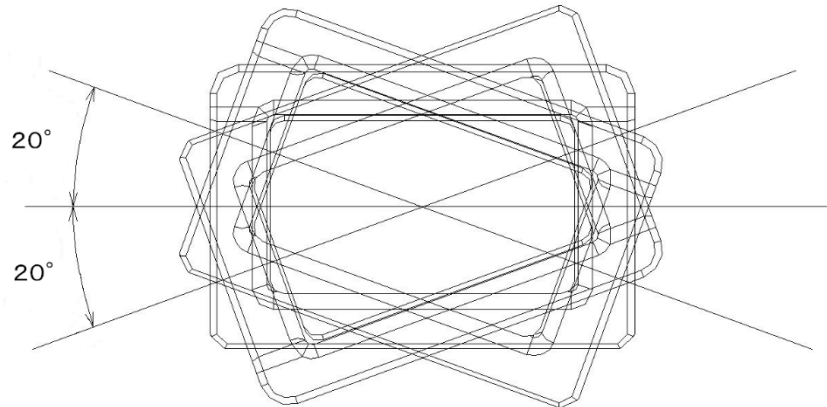

Figure 4: Tilt angle

Conditions:

Barcode Sample: OPTOELECTRONICS Test Sample

Distance: 100 mm from the edge of the scanner

Label: **Pitch Angle, Skew Angle, Dead Zone**

PCS = 0.9, Resolution = 0.25 mm, Symbology = 9-digit Code-39,
Quiet Zone = 10 mm, N/W Ratio = 1:2.5

Tilt Angle

PCS = 0.9, Resolution = 0.26 mm, Symbology = 13-digit JAN, Quiet Zone = 10 mm

Angle: Curvature: $R = \infty$, Skew Angle $\beta = +15^\circ$ (for measuring pitch angle and tilt angle)

7.5 Curvature

With 8-digit JAN barcodes, decoding performance is guaranteed when $R \geq 15$ mm.

With 13-digit JAN barcodes, decoding performance is guaranteed when $R \geq 20$ mm.



Figure 5: Curvature

Conditions:

Barcode Sample: OPTOELECTRONICS Test Sample

PCS = 0.9, Resolution = 0.26 mm, Quiet Zone = 10 mm

Distance: 100 mm from the edge of the scanner

Angle: Skew angle: $\beta = +15^\circ$

8 Interface Specifications

8.1 RS-232C Interface Spec

8.1.1 Settings and Communication

Reading menu barcodes [ZZ] + [U2] + [ZZ] can set the RS-232C interface default.

Item	[U2] setting
Baud rate	9600 BPS
Start/stop bits	1 bit
Data bits	8 bits
Parity bits	No parity
Handshaking	No handshake
Flow control time out	Indefinitely

- You can change the communication condition using the menu barcode.

8.1.2 Signal Level

Signal Name	I/O	RS-232C Level (V)	
		Mark/OFF	Space/ON
TxD	OUT	-5 to -15	+5 to +15
RxD	IN	-3 to -15	+3 to +15
RTS	OUT	-5 to -15	+5 to +15
CTS	IN	-3 to -15	+3 to +15

8.1.3 Interface Circuit

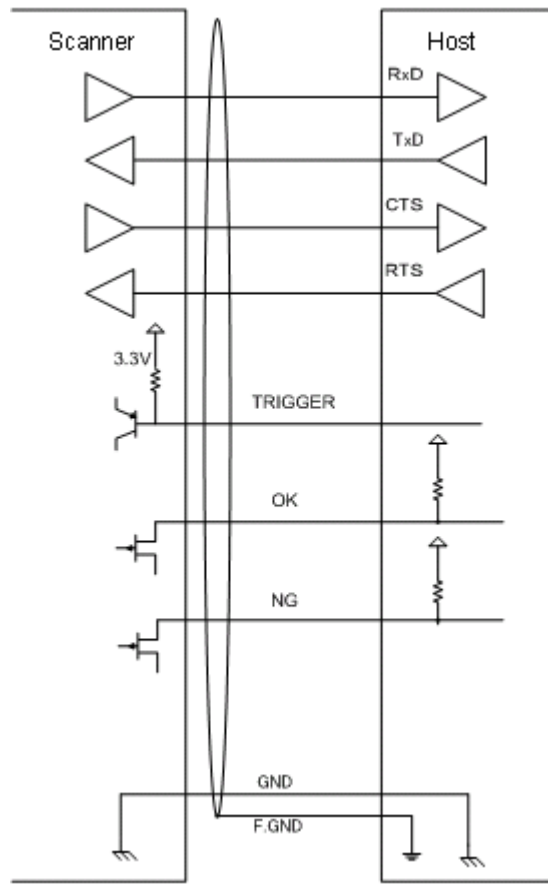

Figure 6: Interface circuit

8.1.4 Character Format

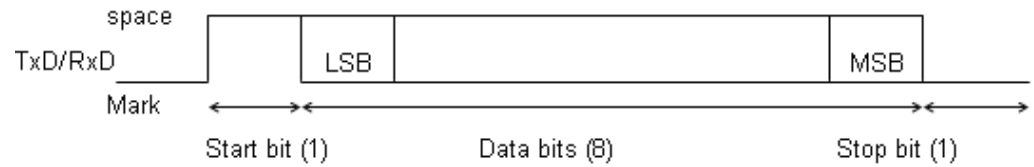

Figure 7: Character format (same for both sending and receiving)

8.1.5 Communication Format

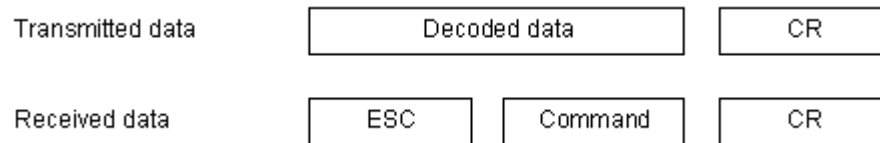

Figure 8: Communication format

8.1.6 Handshaking

Select handshaking options using the menu or command listed below.

Handshaking	Menu/Command
No handshake	P0
BUSY/READY	P1
MODEM	P2
ACK/NAK	P3
ACK/NAK NO RESPONSE	P4

8.1.6.1 No Handshake

The scanner attempts the communication regardless of the state of the host computer.

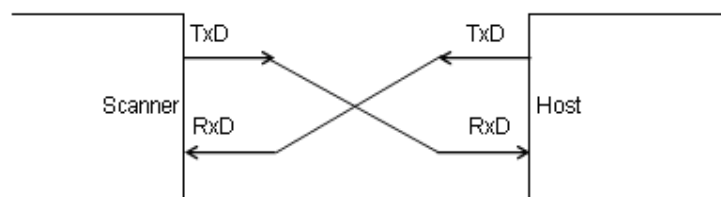

Figure 9: No handshaking

8.1.6.2 BUSY/READY

The scanner and the host computer notify each other of their state and whether they can receive data with BUSY/READY through an RS line. They can communicate state to each other through a CTS line when connected as in the following figure.

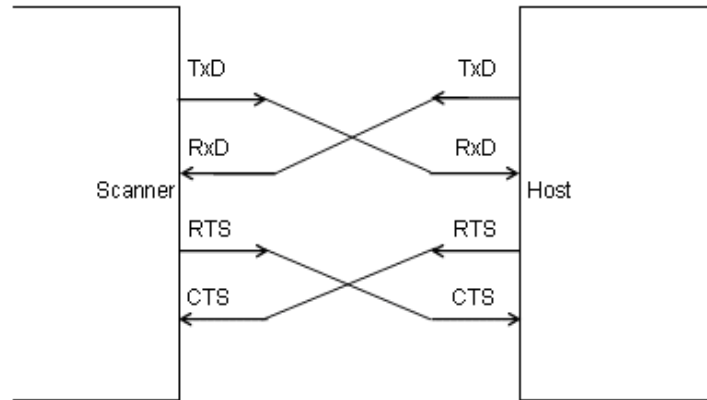

Figure 10: Busy/Ready communication

The scanner stays ON (is able to receive data) except during certain parts of the process, such as receiving data (buzzer command execution), transmitting data, and menu processing. The scanner checks the CTS line before transmitting data. When it is ON, the scanner transmits data. When it is OFF, the scanner waits for it to turn ON within a set time. The scanner will abort transmission with an error indication (buzzer) when the CTS line is not ON within a specified period. The Flow Control time-outs are as follows, and the default setting is “indefinitely“ (10).

Flow Control Time Out	Menu/Command
Indefinitely	10
100 ms	11
200 ms	12
400 ms	13

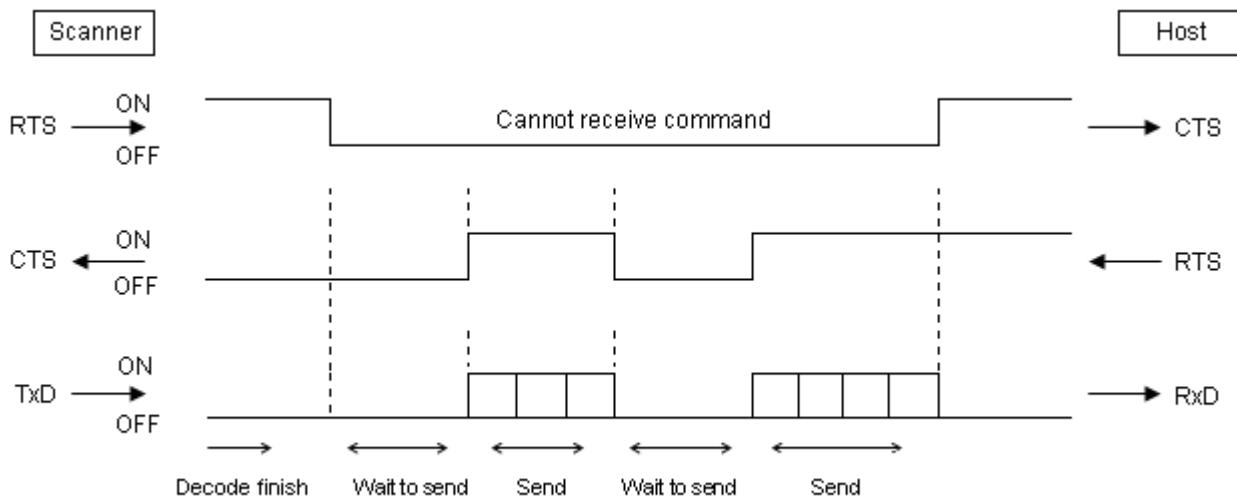

Figure 11: Cannot receive command

CTS, TxD signals timing

When the CTS line is turned OFF while sending a TxD signal, the scanner transmits one character and waits. When the CTS signal is turned ON while transmitting a character, the character will be transmitted.

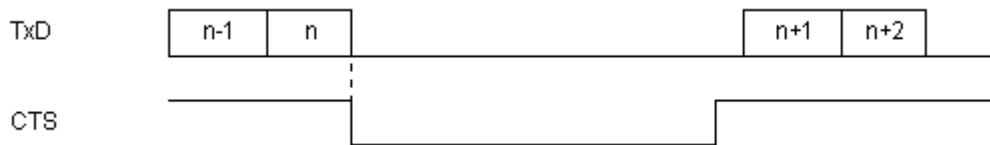

Figure 12: Signal timing

Note: When using loopback (wire connection) for RTS, CTS line of the scanner in this setting, No handshake is not enabled.

8.1.6.3 MODEM

The scanner turns the RTS line ON before transmitting data. Other processes are the same as BUSY/READY.

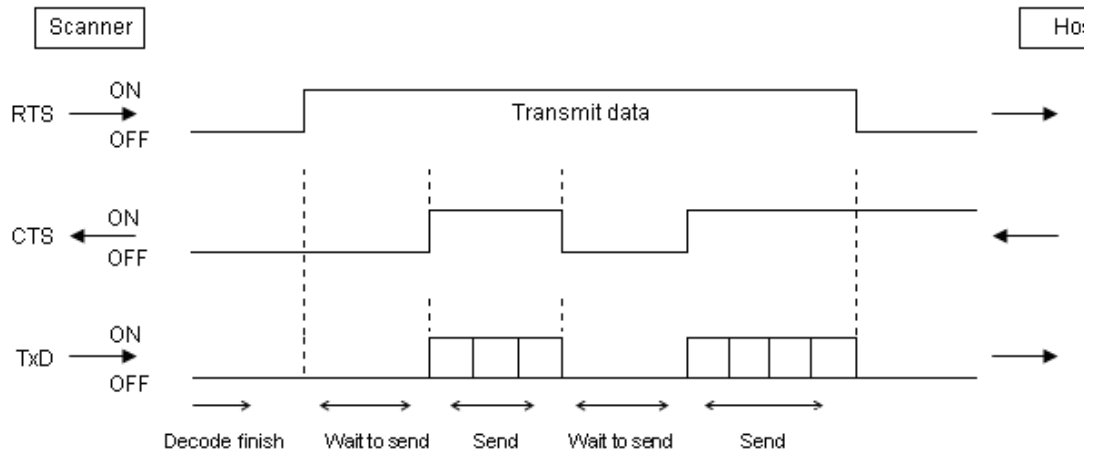

Figure 13: Handshaking—modem

8.1.6.4 ACK/NAK

After data has been transmitted, the scanner expects to receive one of the following responses from the host:

- ACK response—Action: The scanner completes transmission with the good-read buzzer and returns to the initial state.
- NAK response—Action: The scanner sends the data again and waits for the response from the host.
- DC1 response—Action: The scanner returns to waiting for the trigger, if it has a trigger (the initial state).
- *None* response—Action: The scanner sounds the error buzzer and returns to the initial state.

ACK/NAK timeout can be set as follows using the menu or commands.

- I4: Indefinitely (default)
- I5: 100 ms
- I6: 500 ms
- I7: 1000 ms

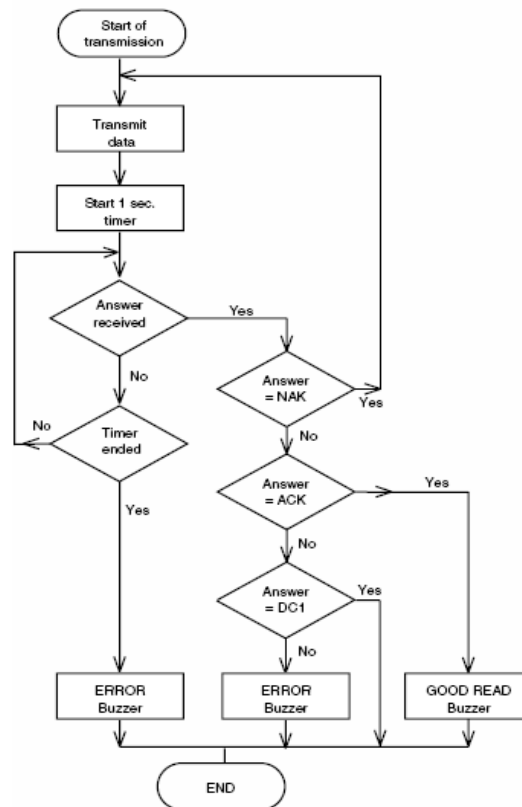

Figure 14: Handshaking—ACK/NAK

8.1.6.5 ACK/NAK—NO RESPONSE

When no response from the host is received within the setting time, the scanner assumes an ACK response, and returns to the initial state without the error buzzer. The other actions are the same as ACK/NAK.

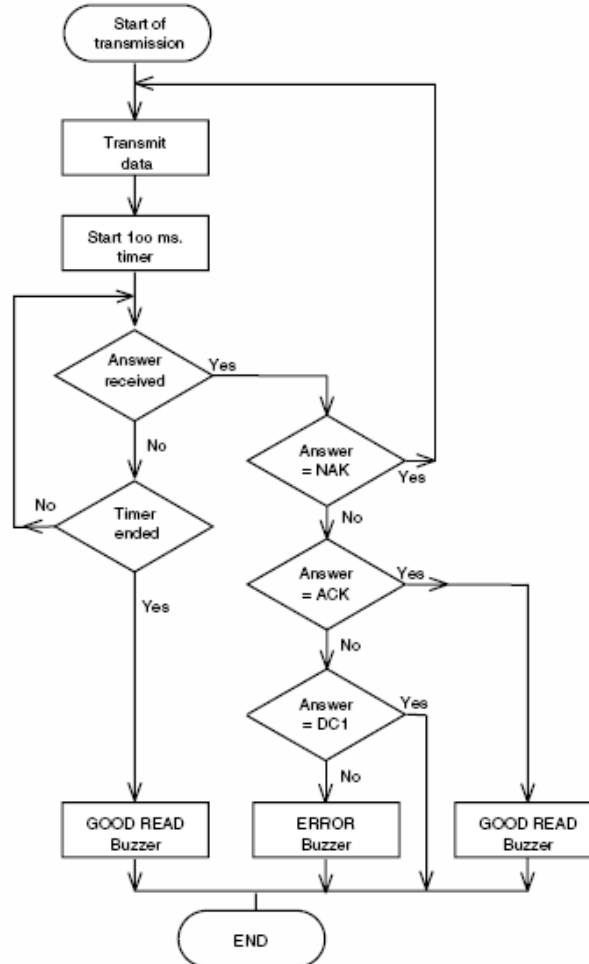

Figure 15: Handshaking—ACK/NAK, no response

8.1.7 OK/NG Signal Output Timing

(NLV 1000 RS-232C Standard Only) The output ON/OFF or the logic can be selected by the menus or commands listed below.

Functions	Menu/Command
SYNC Synchronous H active	X*C (default)
SYNC Synchronous L active	X*D
One shot H active	X*E
One shot L active	X*F
One shot time 10 ms	X*G
One shot time 20 ms	X*H
One shot time 30 ms	X*I
One shot time 40 ms	X*J
One shot time 50 ms	X*K
One shot time 60 ms	X*L
One shot time 70 ms	X*M
One shot time 80 ms	X*N
One shot time 90 ms	X*O
One shot time 100 ms	X*P (default)
Enable sequence output	X*Q (default)
Disable sequence output	X*R

The following figures show examples of output timing when using a pull-up resistor, since the OK/NG output is the FET open drain output.

8.1.7.1 Good Read (Synchronous)

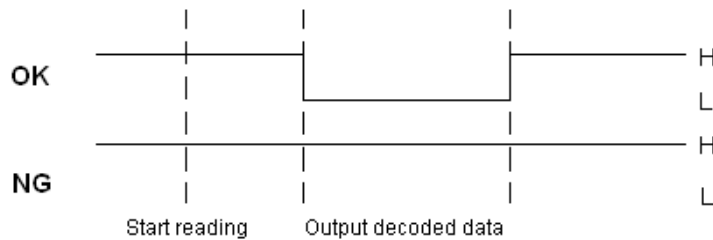

Figure 16: Good read (synchronous)

8.1.7.2 Read Error within Specified Time (Synchronous)



Figure 17: Read error (synchronous)

8.1.7.3 Good Read (One Shot)

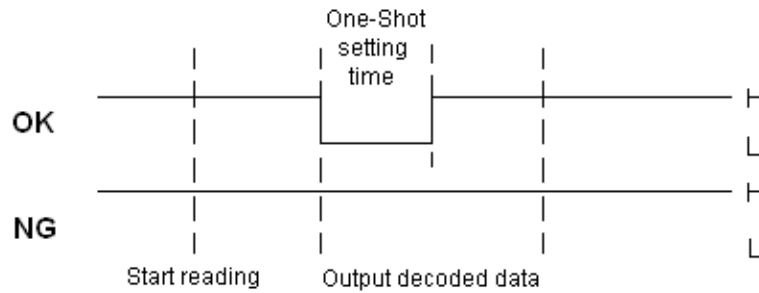

Figure 18: Good read (one shot)

8.1.7.4 Read Error within Specified Time (One Shot)

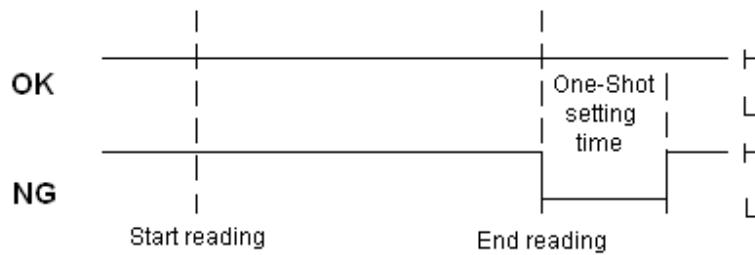

Figure 19: Read error (one shot)

8.2 USB Interface Specifications

8.2.1 Interface

The interface is full-speed USB 1.1.

8.2.2 Interface Circuit

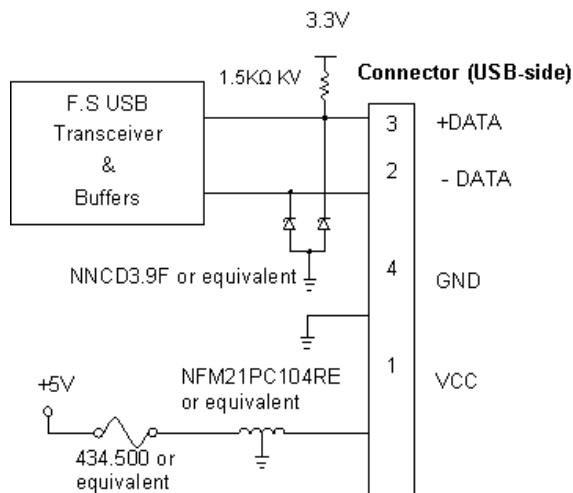

Figure 20: Interface circuit

9 Cable and Connector

9.1 RS-232C Cable

9.1.1 (Standard Specification)

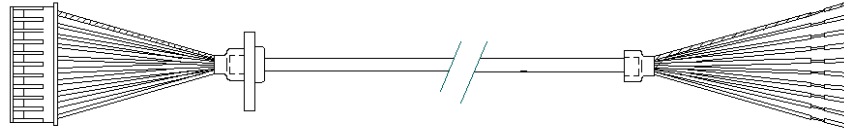

Figure 21: RS-232C cable (standard)

Type:	Straight
Diameter:	$\phi 3.8 \pm 0.5$ mm
Length:	1500 ± 50 mm
Cores:	8 insulated wires, 1 conductive wire
Weight:	Approximately 45 g

9.1.2 D-sub Specification

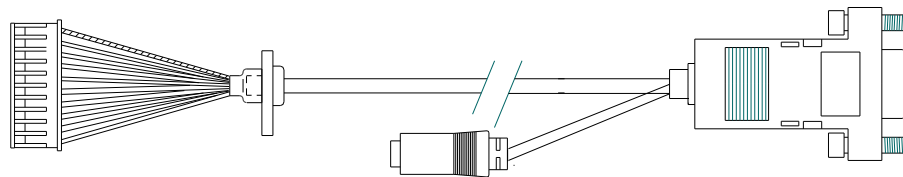

Figure 22: RS-232C cable (D-sub)

Type:	Straight
Diameter:	$\phi 3.8 \pm 0.5$ mm
Length:	1500 \pm 50 mm or 500 \pm 50 mm
Cores:	8 insulated wires, 1 conductive wire
Weight:	Approximately 65 g

9.1.3 Connector Pin-outs

9.1.3.1 Standard Specification

Signal	Pin	Remarks
F.GND	Shield (Black)	Cover shielded wire with heat-shrinkable tubing
GND	Black	
VCC	Red	
TxD	Green	
RxD	White	
RTS	Grey	
CTS	Blue	
NG	Orange	
OK	Yellow	
TRIGGER	Brown	

9.1.3.2 D-sub Specification

9.1.3.2.1 D-sub

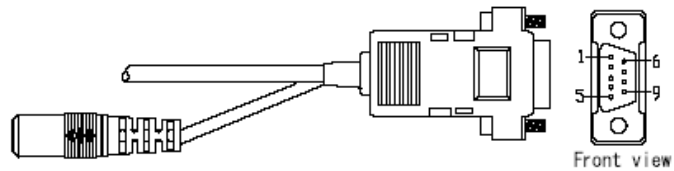

Figure 23: 9-pin D sub female connector (with power stereo jack)

Pin	Signal
1	F.GND
2	TxD
3	RxD
4	NC
5	GND
6	NC
7	CTS
8	RTS
9	NC

9.1.3.2.2 DC Jack

Pin	Signal	Remarks
1	VCC	Inside
2	GND	Outside

9.2 USB Cable

(Standard specification)

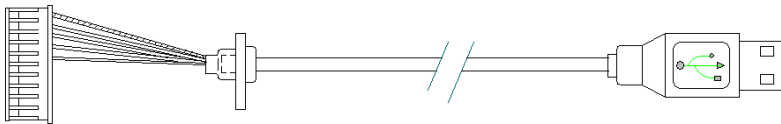

Figure 24: USB cable

Type:	Straight
Diameter:	$\varnothing 3.8 \pm 0.5$ mm
Length:	1500 \pm 50 mm
Cores:	4 insulated wires, 1 conductive wire
Weight:	Approximately 50 g

9.2.1 Connector

USB "A" Connector

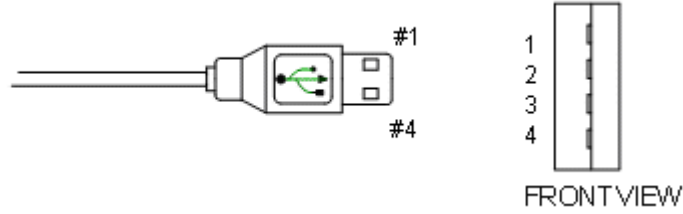

Figure 25: USB "A" connector

9.2.2 Connector Pin-outs

Contact Number	Signal Name
1	VCC
2	-DATA
3	+DATA
4	GND

Do not use the host keyboard while data is being transmitted to the host, or the data may be transmitted incorrectly.

9.3 Connector Specification (Scanner Side)

CN1 (10-pin)

Pin #	Specifications	
	RS-232C	USB
1	TRIGGER	NC
2	OK	NC
3	NG	NC
4	CTS	NC
5	RTS	NC
6	RxD	USB-
7	TxD	USB+
8	VCC	VCC
9	GND	GND
10	SHIELD	SHIELD

10 Default Settings



10.1 Set Default Interface

Scan the following menu barcodes to return to the default settings.

RS-232C



Functions	Menu labels	Menu codes
SET	 z z	ZZ
RS-232C	 u z	U2
END	 z z	ZZ

USB-HID

Functions	Menu labels	Menu codes
SET	 z z	ZZ
USB-HID	 s u	SU
END	 z z	ZZ

USB-VCP

A driver is required and can be downloaded from Opticon's support Web site:
<http://opticonfigure.opticon.com/>.

Functions	Menu labels	Menu codes
SET	 z z	ZZ
USB-VCP	 c 0 1	C01
END	 z z	ZZ

10.2 Default Settings 1: Readable Codes

Symbology	Read	Transmit Code Length	Transmit CD	Calculate CD	Set Prefix	Set Suffix	Other
UPC-A	■	X	■	■	—	CR	
UPC-A Add-on	X	X	■	■	—	CR	
UPC-E	■	X	■	■	—	CR	
UPC-E Add-on	X	X	■	■	—	CR	
EAN-13	■	X	■	■	—	CR	
EAN-13 Add-on	X	X	■	■	—	CR	
EAN-8	■	X	■	■	—	CR	
EAN-8 Add-on	X	X	■	■	—	CR	
Codabar/NW-7	■	X	■	X	—	CR	Not transmit ST/SP
Code 11	X	X	X	■	—	CR	
Code 39	■	X	■	X	—	CR	Not transmit ST/SP
Code 93	■	X	X	■	—	CR	
Code 128	■	X	X	■	—	CR	
EAN-128	X	X	X	■	—	CR	
IATA	■	X	■	X	—	CR	
Industrial2of5	■	X	■	X	—	CR	
Interleaved2of5	■	X	■	X	—	CR	
Matrix2of5	X	X	■	X	—	CR	
MSI/Plessey	■	X	■CD1	■CD1	—	CR	
UK/Plessey	■	X	■	■	—	CR	
RSS-14	X	X	■	■	—	CR	
RSS-limited	X	X	■	■	—	CR	
RSS-expanded	X	X	■	■	—	CR	
S-Code	■	X	■	X	—	CR	
Telepen	■	X	■	■	—	CR	
Trioptic	■	X	■	X	—	CR	Not transmit ST/SP

Notes:

In the “Reading” column, “■” means “Enable reading” and “X” means “Disable reading.”

In the “Transmit code length” column, “■” means “Transmit code length” and “X” means “Do not transmit code length.”

In the “Transmit CD” column, “■” means “Transmit check digit” and “X” means “Do not transmit check digit.”

In the “Calculate CD” column, “■” means “Calculate check digit” and “X” means “Do not calculate check digit.”

“— “ means “not supported.”

In the “Prefix” column, “—“ means “there is no prefix setting.”

10.3 Default Settings 2: Read Options, Trigger, Buzzer

Item		Default Setting
Setting the number of characters		Fixed length OFF all codes
Read mode		Multiple read
Multiple read reset time		500 ms
Add-on wait mode		500 ms
Multiple label read		Disable
Multiple column read		Disable
Redundancy	Default option ([X0] setting)	Read 1 times, redundancy = 0
	Other options ([X1 .. X3] setting) ([BS .. BW] setting)	Read n times, redundancy = n+1 for the following symbologies and lengths: <ul style="list-style-type: none"> • Code 11 with length <= 5 • Code 39 with length <= 5 • IATA, Industrial 2of5, Interleaved 2of5 with length <= 8 • Matrix 2of5 (& Chinese Post), Scode with length <= 8 • MSI/Plessey with length <= 4 • NW-7 (Codabar) with all lengths
Trigger switch		Enable
Trigger repeat		Disable
Auto trigger		Disable
Read time		2 seconds (when trigger enabled)
Margin check		Normal
Buzzer duration		50 ms
Buzzer tone		Single tone (3 kHz)
Buzzer loudness		Maximum
Buzzer transmission		Before transmission
Startup buzzer		Enable
Good read LED		Indicator duration 200 ms

11 Serial Number and Labeling

11.1 Serial Number

The serial number shown below is affixed to the scanner.

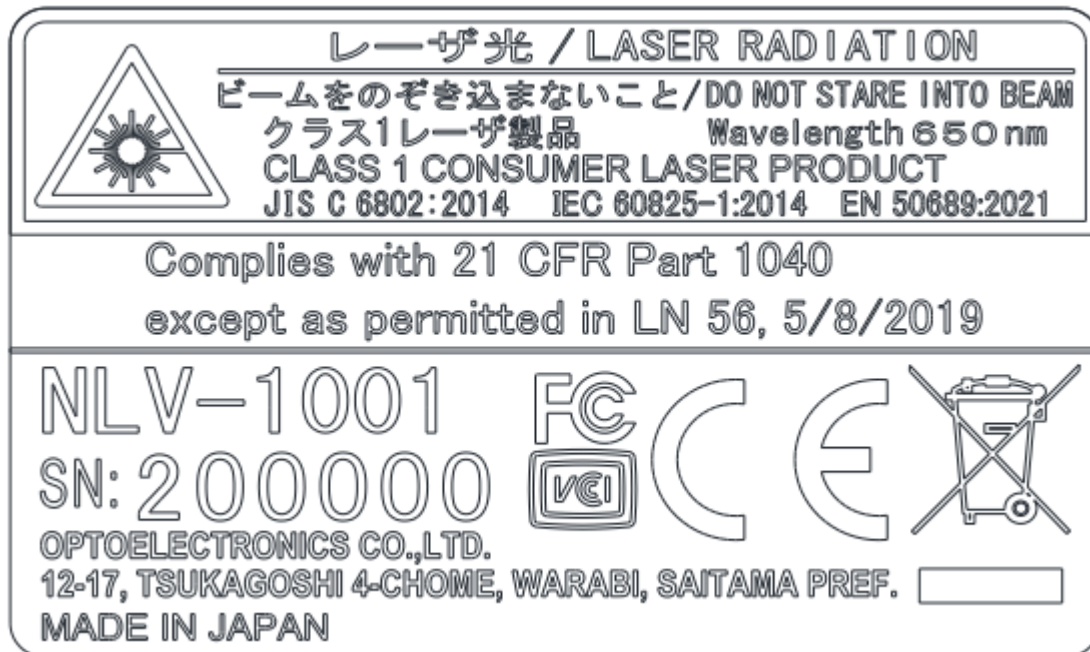

Figure 26: Serial number diagram

Serial numbers are six-digit numbers and start from number 000001 regardless of batch.

12 Packaging Specifications

12.1 Individual Packaging Specification

Put the scanner in a protective foam bag and place it in an individual packing box.

Size of the package (after assembly):

- USB: 120 (W) X 110 (D) X 40 (H) mm
- RS-232 240 (W) X 110 (D) X 40 (H) mm

12.2 Collective Packaging Specification

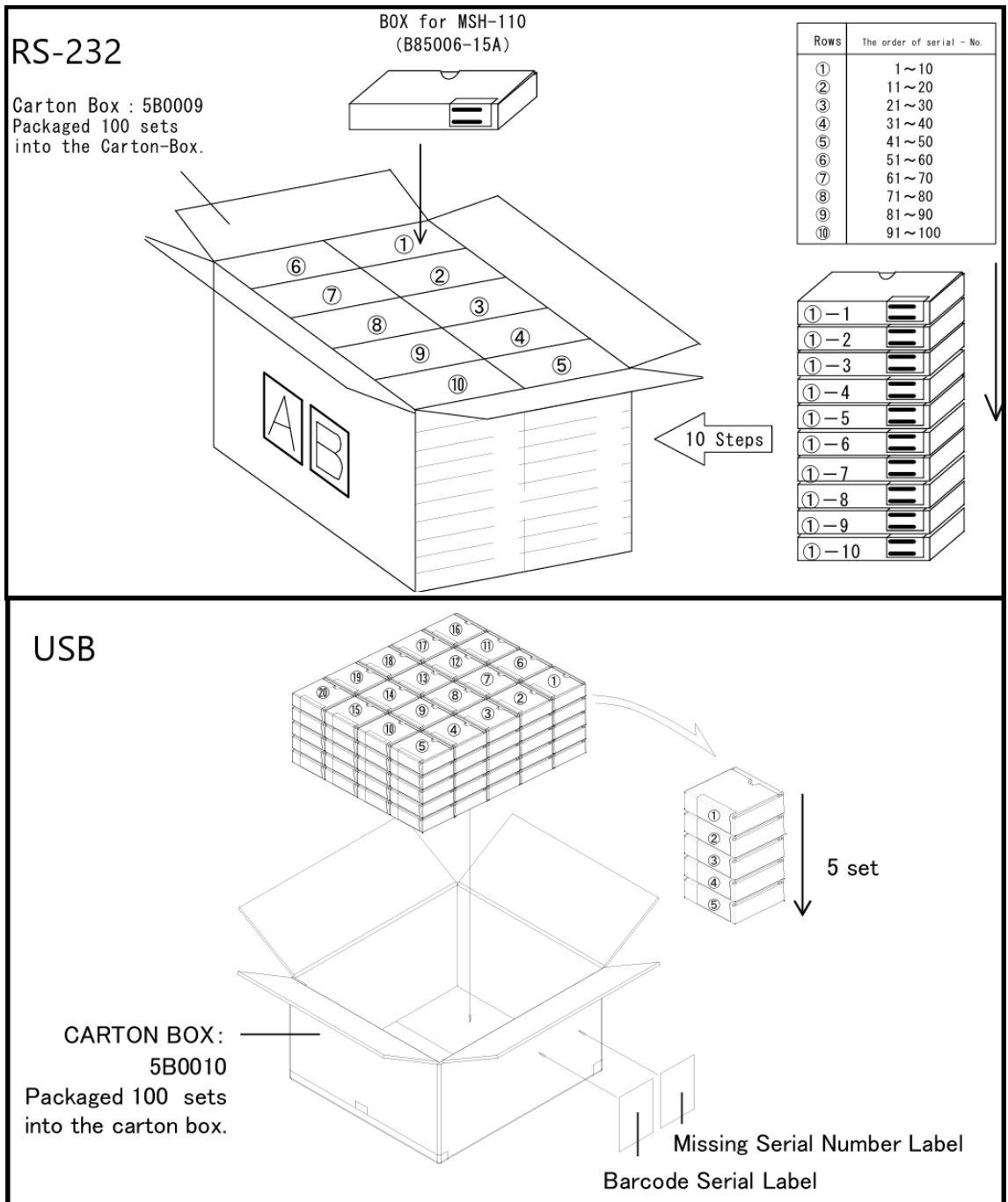

Figure 27: Packaging the NLV 1001

13 Durability

13.1 Electrical Noise

No malfunction occurred when sinusoidal electrical noise (50 Hz–100 kHz, < 0.1 Vp-p) was added to the power supply line.

Conditions

Barcode Sample: OPTOELECTRONICS Test Sample

PCS	0.9
Resolution	0.25 mm
Symbology	9-digit Code 39
Quiet Zone	10 mm
N/W Ratio	1:2.5
Distance	150 mm
Angle	$\alpha = 0^\circ \beta = 15^\circ \gamma = 0^\circ$
Curvature	$R = \infty$
Power Supply Voltage	5.0 V

13.2 Static Electricity

Air discharge:	± 8 kV max. (No malfunction) ± 10 kV max. (No destruction)
Measurement environment:	Use electrostatic testing device compliant with IEC 61000-4-2
Discharge resistance:	330 Ω
Capacitor charging:	150 pF

13.3 Shock

13.3.1 Drop Test (without packaging)

No malfunction occurred after the following drop test.

Drop Test: Drop the scanner from a height of 75 cm onto a concrete floor (once in each of five directions).

13.4 Vibration Strength

No malfunction occurred after the following vibration test.

Vibration test: Increase the frequency of the vibration from 12 Hz to 100 Hz with accelerated velocity 19.6 m/s^2 (2 G) for 60 minutes in non-operating state. Repeat this routine in each X, Y, Z direction once for 60 minutes each.

13.5 Dust and Drip Proof

IEC IP43

Dust Prevention

Level	Details
4	Prevention of objects larger than 1 mm. Most wires, screws, etc.

Water Prevention

Level	Details
3	Water falling as a spray at any angle up to 60° from the vertical shall have no harmful effect.

14 Reliability

MTBF (Mean Time Between Failures) of this product except for the laser diode and the mirror motor scan unit is 30,000 hours.

Life cycle of the laser diode is 10,000 hours and that of the mirror motor scan unit is also 10,000 hours.

The estimate of MTBF and product life cycle is based on standard operation of the product within the recommended temperature range and without extreme electronic or mechanical shock.

15 Trigger and Read Options

The NLV 1001 has read and trigger settings as follows:

15.1 Auto Trigger Sensor

When auto trigger is used, the scanner starts barcode reading after detecting a change in reflection in the detection area. The scanner will be triggered if the sensors detect changes in brightness in the detection area.

Auto trigger distance: 50 ±10 mm from the edge of the scanner.

Conditions

Moving speed:	100 ±10 mm/s
Angle:	Vertical to the edge of the scanner
Environmental temperature and humidity:	Room temperature and humidity
Environmental illuminance:	500 to 900 lx
Conditions for the auto trigger:	1. Barcode sheet: OPTOELECTRONICS Test Sheet (white) Background: OPTOELECTRONICS Test Sheet (black) 2. Barcode sheet: OPTOELECTRONICS Test Sheet (black) Background: OPTOELECTRONICS Test Sheet (white)

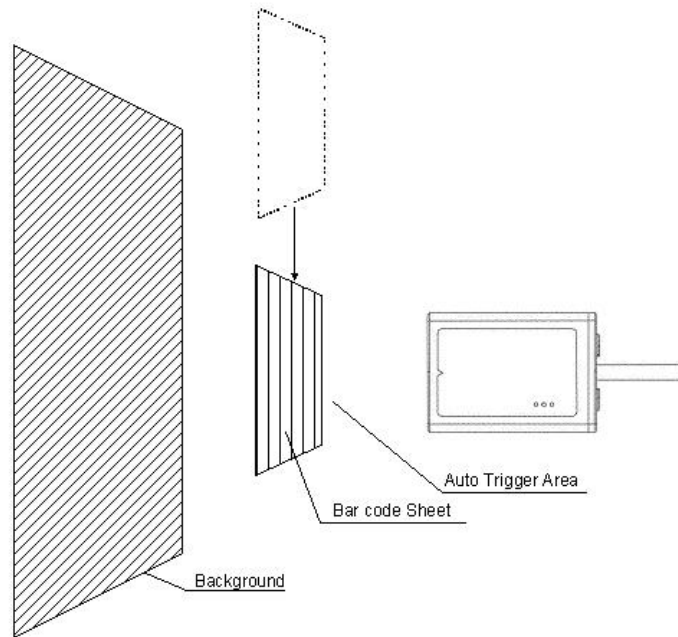

Figure 28: Auto trigger detection area

15.2 Auto Trigger Enable/Disable Settings

Use the following settings to enable or disable the auto trigger. (Auto trigger is disabled by default).

To enable auto trigger, scan “ZZ”, “+I” and “ZZ” in that order.

To disable auto trigger, scan “ZZ”, “+F” and “ZZ” in that order.

Functions	Menu labels	Menu codes
SET		ZZ
Disable auto trigger		+F
Enable auto trigger		+I
END		ZZ

16 Regulatory Compliance

Please see the Declaration of Conformity on the Opticon website download page.

17 Safety

Handle this product carefully. Do not deliberately subject it to any of the following.

17.1 Shock

Do not throw or drop the scanner.

Do not place heavy objects on the cables.

17.2 Temperature Conditions

Do not use the scanner at temperatures outside the specified range.

Do not pour boiling water on the scanner.

Do not throw the scanner into the fire.

Do not forcibly bend the cables at low temperatures.

17.3 Foreign Materials

Do not immerse the scanner in liquids.

Do not subject the scanner to chemicals.

17.4 Other

Do not plug/unplug the connectors before disconnecting the power.

Do not disassemble this product.

Do not place the product near a radio or a TV receiver, as the scanner may cause reception problems.

The scanner may be damaged by voltage drops.

The scanner may not perform properly in environments when placed near a flickering light, such as a computer monitor, television, etc.

18 Mechanical Drawing

Dimensions: 30 X 20 X 43.3 mm (cable not shown)

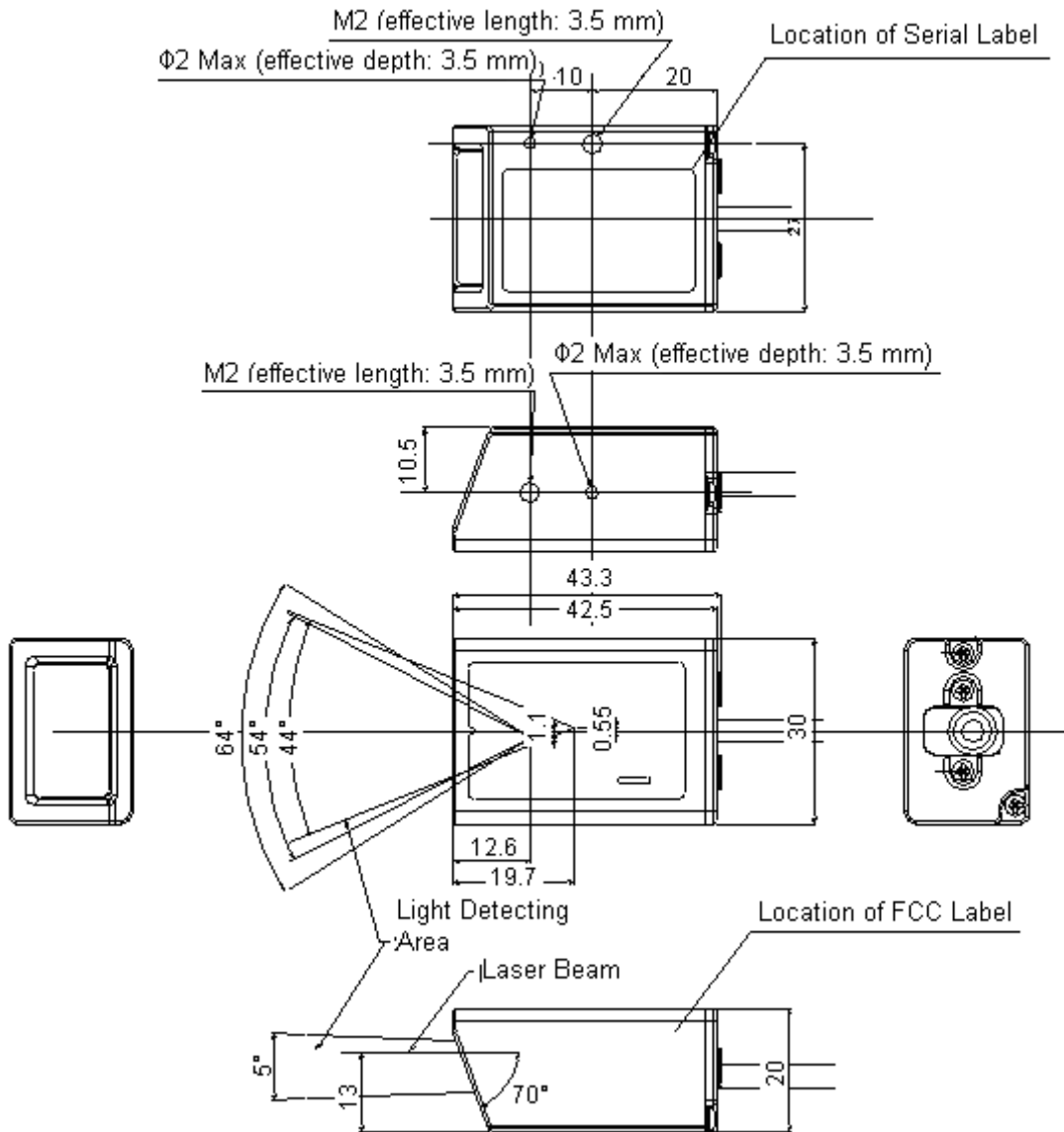

Figure 29: Mechanical drawing