

# Serial Interface Software Manual



**MDI-4600**

**MDI-4700**

**Low Profile High-Performance 2D Imager Engine**

The information in this document is subject to change without notice.

## Document History

Model Number:	MDI-4600/4700	Specification Number:	
Edition:	Serial Interface Software Manual	Original Spec Number:	(-)
Date:	2024/10/30		

## © 2024 Opticon. All rights reserved.

This manual may not, in whole or in part, be copied, photocopied, reproduced, translated or converted to any electronic or machine-readable form without prior written consent of Opticon.

## Limited Warranty and Disclaimers

Please read this manual carefully before installing or using the product.

### Serial Number

A serial number appears on all Opticon products. This official registration number is directly related to the device purchased. Do not remove the serial number from your Opticon device. Removing the serial number voids the warranty.

### Warranty

Unless otherwise agreed in a written contract, all Opticon products are warranted against defects in materials and workmanship for two years after purchase, excluding batteries. Opticon will repair or, at its option, replace products that are defective in materials or workmanship with proper use during the warranty period. Opticon is not liable for damages caused by modifications made by a customer. In such cases, standard repair charges will apply. If a product is returned under warranty and no defect is found, standard repair charges may apply. Opticon assumes no liability for any direct, indirect, consequential, or incidental damages arising out of use or inability to use both the hardware and software, even if Opticon has been informed about the possibility of such damages. Root cause analysis report services to troubleshoot defects or application issues are not covered under this limited warranty.

### Packaging

The packing materials are recyclable. We recommend that you save all packing material to use should you need to transport your imager engine or send it for service. Damage caused by improper packaging during shipment is not covered by the warranty.

### Trademarks

Trademarks used are the property of their respective owners.

Opticon Inc. and Opticon Sensors Europe B.V. are wholly owned subsidiaries of OPTOELECTRONICS CO.,LTD., 12-17, Tsukagoshi 4-chome, Warabi-shi, Saitama, Japan 335-0002. TEL +81-(0) 48-446-1183; FAX +81-(0) 48-446-1184

## SUPPORT

### USA

Phone: 800-636-0090  
Email: [support@opticonusa.com](mailto:support@opticonusa.com)  
Web: [www.opticonusa.com](http://www.opticonusa.com)

### Rest of World

Phone: +31235692728  
Email: [support@opticon.com](mailto:support@opticon.com)  
Web: [www.opticon.com](http://www.opticon.com)

## Revision History

Document Name : MDI-4600/4700

Edition	Date	Section	Description of Changes	Supported Firmware
1st	2024.04.18	-	Initial release	BJ01J01
2nd	2024.06.25	4.1.6	Update MODEM diagram.	
2.1	2024.10.30	-	Updated to new layout	

## Table of Contents

<b>Revision History</b> .....	<b>3</b>
<b>1. Overview</b> .....	<b>10</b>
1.1. About the MDI-4600 and MDI-4700 Imager Engine .....	11
1.2. Integration Flow .....	12
<b>2. Before Using</b> .....	<b>13</b>
2.1. Model Details .....	14
2.1.1. Standard Product Description	14
2.1.2. Model Description	14
2.2. Scan Area .....	15
2.3. Optional Accessories .....	16
<b>3. Configuring the MDI-4600 and MDI-4700</b> .....	<b>17</b>
3.1. Configuring with Commands .....	18
3.1.1. Configuring with a Command Packet	18
3.1.2. Configuring with 2D Menu Codes	20
3.1.3. Configuring with 1D Menu Codes	21
3.2. Command Packet Sending Precautions .....	22
3.2.1. Interface Default Setting	23
3.2.2. Save Settings	23
3.2.3. Custom Settings	23
3.3. Custom Command Line Settings (Change the Factory Default Settings) .....	24
3.4. Fast Boot Mode .....	25
3.5. Basic Commands .....	26
3.5.1. Trigger Command	26
3.5.2. Diagnostic Commands	27
3.5.3. ACK/NAK for Serial Commands	28
3.5.4. Reboot the Imager Engine	29
3.5.5. Enable/Disable 2D Menu Codes	29
3.5.6. Enable/Disable 1D Menu Code	29
3.5.7. Image Settings	30
3.5.8. Disable Reading Operation	31
3.5.9. Buzzer and Indicator	31
3.5.10. Direct Numerical Input Command	31
3.6. Forced Initialization .....	32
<b>4. Interface Options</b> .....	<b>33</b>
4.1. UART .....	34
4.1.1. Switch the Interface to UART	35
4.1.2. UART Interface Signal	36
4.1.3. UART Basic Information	37
4.1.4. Baud Rate (Transfer Speed)	37

4.1.5.	Character Format	38
4.1.6.	Handshaking (Flow Control)	38
4.1.7.	Inter Character Delay (UART)	43
4.1.8.	Troubleshooting UART	43
4.2.	USB-COM.....	44
4.2.1.	Switch the Interface to USB	45
4.2.2.	USB Interface Signal	46
4.2.3.	USB-COM Basic Information	47
4.2.4.	Integration (USB driver)	47
4.2.5.	USB-COM Connection Confirmation	48
4.2.6.	Fixed USB-COM Port	48
4.2.7.	Connection Method	49
4.2.8.	COM to HID Output (WIME)	49
4.2.9.	Troubleshooting USB-COM	50
4.3.	USB-HID.....	51
4.3.1.	Switch the Interface to USB-HID	52
4.3.2.	USB Interface Signal	53
4.3.3.	USB-HID Basic Information	54
4.3.4.	USB-HID Connection Confirmation	55
4.3.5.	NumLock and CapsLock Control	55
4.3.6.	Data Output Speed (USB-HID)	56
4.3.7.	USB-HID Inter Character Delay	56
4.3.8.	Keyboard Language	57
4.3.9.	Multi-Byte Character Output	58
4.3.10.	Multi-Byte Character Output Setting	59
4.3.11.	Troubleshooting USB-HID	64
4.3.12.	USB-HID Precautions	64
4.4.	Common Settings.....	65
4.4.1.	Data Buffer Mode	65
<b>5.</b>	<b>Power Management and Timing.....</b>	<b>66</b>
5.1.	Power Mode Transition .....	67
5.2.	Current Consumption .....	68
5.2.1.	Absolute Maximum Ratings	68
5.2.2.	Recommended Operating Conditions	68
5.2.3.	Peak Current Consumption	68
5.2.4.	Current Consumption of the MDI-4600 and MDI-4700	69
5.3.	Low Power.....	70
5.3.1.	Enable/Disable Low Power	70
5.3.2.	Transition Time	70
5.3.3.	USB Low Power Mode Transition Condition	71
5.3.4.	USB Low Power Mode Communication Sequence	72

- 5.4. Recovery from Low Power Mode ..... 73
  - 5.4.1. Recovery from Low Power Mode by Signal (UART) 73
  - 5.4.2. Recovery from Low Power Mode by Command (UART) 74
  - 5.4.3. Recovery from Low Power Mode (USB) 75
- 5.5. Power ON/OFF Timing ..... 76
  - 5.5.1. Power-On Timing 76
  - 5.5.2. Power-Off Timing 77
- 5.6. Read Timing ..... 78
  - 5.6.1. Read Effective Time 79
  - 5.6.2. Trigger Signal Control 80
  - 5.6.3. Command Trigger Control 81
  - 5.6.4. Trigger Delay 82
  - 5.6.5. Decode Timeout 82
- 6. Code Options ..... 83**
  - 6.1. Setting Readable Codes ..... 84
    - 6.1.1. 1D Codes 84
    - 6.1.2. Postal Code 85
    - 6.1.3. GS1 DataBar 86
    - 6.1.4. GS1 Composite Code 86
    - 6.1.5. 2D Codes 87
    - 6.1.6. OCR 88
    - 6.1.7. Code Type Settings 88
  - 6.2. Setting Code Common Options ..... 89
    - 6.2.1. GS1 Convert 89
    - 6.2.2. Positive and Negative Image of Barcodes (1D Code Common) 90
    - 6.2.3. Smart Quiet Zone (1D Code) 91
    - 6.2.4. Redundancy (1D Barcode Common) 92
    - 6.2.5. Add-On Waiting Time 92
    - 6.2.6. ECI Protocol Output 93
    - 6.2.7. OCR Free Edit 94
    - 6.2.8. DPM (Dot Peen Making) Code Reading 95
  - 6.3. Setting Code Specific Options ..... 96
    - 6.3.1. UPC 96
    - 6.3.2. EAN/JAN 99
    - 6.3.3. Code 39 and It. Pharm 103
    - 6.3.4. Codabar 105
    - 6.3.5. Interleaved 2 of 5 107
    - 6.3.6. Code128 108
    - 6.3.7. IATA 109
    - 6.3.8. MSI/Plessey 109
    - 6.3.9. UK/Plessey 109

- 6.3.10. Telepen 109
- 6.3.11. Code 11 110
- 6.3.12. Korean Postal Authority 110
- 6.3.13. GS1 DataBar 111
- 6.3.14. GS1 DataBar Composite 112
- 6.3.15. PDF417 113
- 6.3.16. QR Code 114
- 6.3.17. Data Matrix 117
- 6.3.18. Aztec Code 118
- 6.4. Setting the Number of Characters ..... 119
  - 6.4.1. Fixed Length ON, Minimum/Maximum Length for Selected Codes 119
  - 6.4.2. Command List: Fixed Length ON/Minimum/Maximum Length 120
- 7. String Options ..... 121**
  - 7.1. Case Conversion ..... 122
  - 7.2. Prefix/Suffix (Appending Characters) ..... 123
    - 7.2.1. Set Prefix/Suffix 124
    - 7.2.2. Command List: Prefix/Suffix Settings 125
    - 7.2.3. ASCII (Prefix/Suffix Values) 127
    - 7.2.4. Code ID 128
    - 7.2.5. Code Length 128
    - 7.2.6. Code Coordinates 129
    - 7.2.7. Code Tilt Angle 130
    - 7.2.8. Scan Time 131
    - 7.2.9. Bank Number 131
- 8. Read Options ..... 132**
  - 8.1. Read Modes ..... 133
    - 8.1.1. Read Modes 133
    - 8.1.2. High-Speed Slide Read Mode 135
    - 8.1.3. Toggle Trigger Mode 135
    - 8.1.4. Disable Trigger (Always Read) 135
    - 8.1.5. Central Reading 136
    - 8.1.6. Central Reading Range 137
  - 8.2. Manual Trigger ..... 138
    - 8.2.1. Trigger Repeat 138
  - 8.3. Auto Trigger ..... 139
    - 8.3.1. Normal Auto Trigger 139
    - 8.3.2. Auto Trigger Sensitivity 139
    - 8.3.3. Double Read Reset Time 139
    - 8.3.4. Read Time Adjustment 140
    - 8.3.5. Auto Trigger Sleep Transition Time 140
    - 8.3.6. Detection Mode 140

- 8.4. Illumination and Aiming ..... 141
  - 8.4.1. Reading LED Illumination 141
  - 8.4.2. External LED Illumination 142
  - 8.4.3. LED Aiming 142
- 8.5. Batch Reading/Data Edit Function ..... 143
  - 8.5.1. Batch Reading 143
  - 8.5.2. Data Edit Reading 144
- 8.6. Auto Exposure Control ..... 145
  - 8.6.1. Target Brightness 145
  - 8.6.2. Exposure Control Area 146
- 8.7. Exposure Fixation ..... 147
  - 8.7.1. Fixing the Exposure Time 147
  - 8.7.2. Fixing the Sensor Gain (Amplification Factor) 147
  - 8.7.3. Confirm the Fixed Status of Exposure Time and Sensor Gain 147
  - 8.7.4. Confirm the Fixed Values of the Exposure Time and Sensor Gain 148
- 8.8. Tuning Function ..... 149
  - 8.8.1. Tuning Function Overview 149
  - 8.8.2. Tuning Setting Flow 150
  - 8.8.3. Execute Tuning 151
  - 8.8.4. Motion Tolerance Setting (Setting the Exposure Adjustment Range of Tuning) 152
- 8.9. Bank Function ..... 153
  - 8.9.1. Bank Selection 153
  - 8.9.2. Bank Specify Trigger 153
  - 8.9.3. Confirm Current Bank 154
  - 8.9.4. Initialize Bank 154
  - 8.9.5. Bank Switching 154
- 8.10. Decode Area ..... 155
- 8.11. Reading Test Command ..... 157
- 8.12. Error Message ..... 158
- 9. Indicator Options ..... 159**
  - 9.1. Buzzer (BUZZERn Signal) ..... 160
    - 9.1.1. Buzzer Loudness 160
    - 9.1.2. Good Read Buzzer 160
    - 9.1.3. Start-Up Buzzer 161
    - 9.1.4. Read Timeout Buzzer 161
    - 9.1.5. Intermediate Buzzer 161
    - 9.1.6. Idle Level of BUZZERn Pin 161
  - 9.2. Good Read LED (GR\_LEDn Signal) ..... 162
    - 9.2.1. Good Read LED 162
    - 9.2.2. Inversion of Good Read LED 162
  - 9.3. Good Read Aiming ..... 163

9.4.	Common Indicator Settings .....	164
9.4.1.	Indicator Timing	164
<b>10.</b>	<b>Appendix.....</b>	<b>165</b>
10.1.	Code ID Table.....	166
10.1.1.	Opticon Code ID Prefix/Suffix Value	166
10.1.2.	Code Option AIM/ISO15424 Code ID Prefix/Suffix Values	167
10.2.	MDI-4600 and MDI-4700 Specification Overview .....	171
10.2.1.	Common Specification Overview	171
10.2.2.	MDI-4700 Drawing	174
10.3.	Sample Codes .....	177
10.3.1.	1D Code	177
10.3.2.	Postal Code	181
10.3.3.	GS1 DataBar	182
10.3.4.	GS1 Composite Code	183
10.3.5.	2D Code	185
10.3.6.	OCR Font (Machine Readable Travel Document)	187
10.3.7.	OCR Font (Free OCR Edit)	188
10.4.	Imager Engine Software Information .....	189

## 1 Overview

This document provides the serial interface specifications for the MDI-4600 and MDI-4700 imager engine (hereafter called “imager engine”)

1.1 [About the MDI-4600 and MDI-4700 Imager Engine](#)

1.2 [Integration Flow](#)

## 1.1 About the MDI-4600 and MDI-4700 Imager Engine

The MDI-4600 and MDI-4700 are low-profile, imager-based, barcode imager engines with an integrated decoder that enables high-speed scanning of 1D (linear) and 2D codes, as well as OCR fonts.

The MDI-4600 and MDI-4700 includes these features:

- **Best-in-class depth of field (DOF) and minimum resolution.**  
The MDI-4600 and MDI-4700 provide best-in-class DOF and minimum resolution, such as a 0.127 mm (5 mil) 2D barcode with a high-quality optical design and components and an enhanced decoder.
- **World's fastest motion tolerance**  
The MDI-4600 and MDI-4700 provide the world's fastest motion tolerance (10 m/s), which enables snappy scanning performance.
- **Low power consumption**  
The high-performance and customized low-power 800MHz CPU has drastically minimized the power consumption in operating, standby, low power states, and booting.
- **Upward compatibility**  
The MDI-4600 and MDI-4700 have the same form factor, mounting holes, and 12-pin connector as the MDI-4xx0 series to enable quick migration.
- **High-speed image sensor**  
The high-speed CMOS image sensor in the MDI-4600 and MDI-4700 captures images at a speed of up to 120 fps. Combined with the fastest global shutter speed in the industry, this enables fast and accurate scanning.
- **Green LED aiming and warm-white LED illumination**  
A well-defined single line of green LED light and efficient warm-white LED illumination supports easy aiming while ensuring safety and long-life.
- **Data Edit Programing**  
Capable of batch reading 1D codes (up to 16 pieces), 2D codes, and OCR. The combined output is highly configurable using regular expressions. Also supports GS1 data conversion and code coordinate output.
- **RoHS compliance**  
The MDI-4600 and MDI-4700 are RoHS compliant products, as declared by Optoelectronics Co., Ltd.

## 1.2 Integration Flow

Follow these steps to integrate the imager engine.

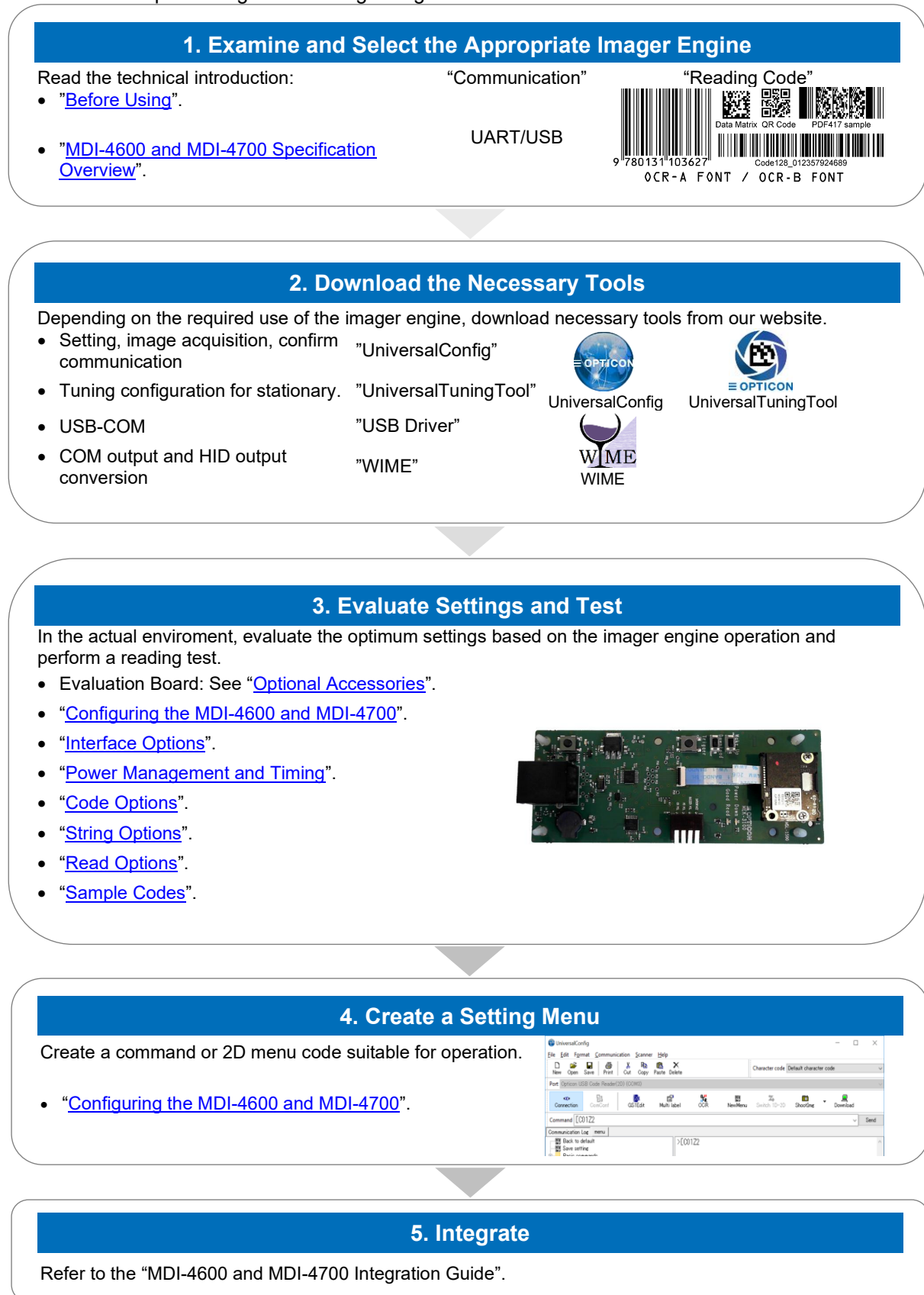

## 2 Before Using

Following explains the items required before using.

### 2.1 [Model Details](#)

#### 2.2 [Scan Area](#)

#### 2.3 [Optional Accessories](#)

## 2.1 Model Details

The imager engine model name is comprised of these elements.

Model Name	Focus	Interface
MDI-4700	SR	B
MDI-4600	HD	DC
	UD	D

### 2.1.1 Standard Product Description

The standard product models have these specifications.

Model	Description
MDI-4700 SRB	Decoder board integrated, Standard focus, Interface: UART
MDI-4600 SRB	Decoder board separated, Standard focus, Interface: UART

**Note:** You may be able to special order additional combinations. For help, contact your local sales office.

### 2.1.2 Model Description

The model number indicates the shape of the imager engine.

Model	Description
MDI-4700	Decoder board integrated imager engine. Low-power consumption mode installed.
MDI-4600	Decoder board separated imager engine. Low-power consumption mode installed.

#### Focus

Symbol	Description
SR	Standard focus (115 mm).
HD	High-resolution focus (65 mm).
UD	Ultra high-resolution (45 mm).

#### Factory Interface Initial Setting

Symbol	Description
B	UART
DC	USB-COM
D	USB-HID

## 2.2 Scan Area

The imager engine reads the code by acquiring the image. The dashed square box is not actually visible. When reading, the target is the LED Aiming beam.

For reading depth of field, see “[Common Specification Overview](#)”. To configure the imager engine to only read the center of LED aiming, see “[Central Reading](#)”.

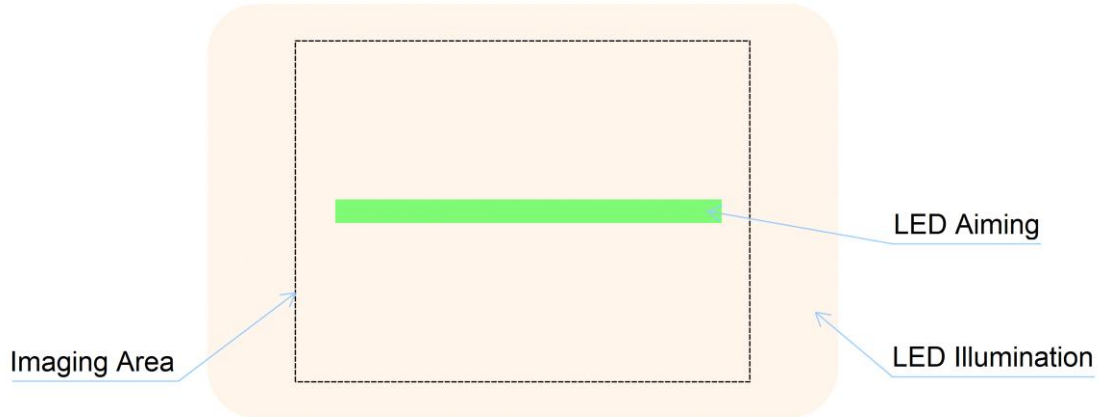

Correct LED aiming:

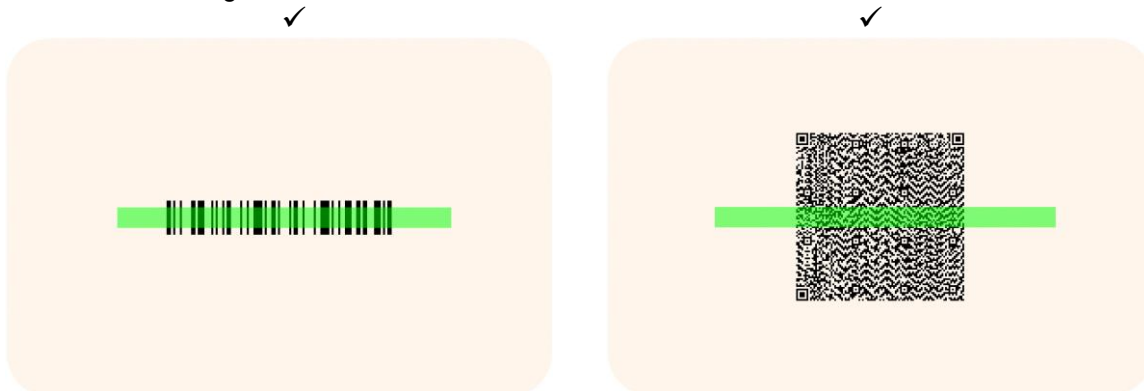

Note: If the code (including the quiet zone) is within the view angle, the code can be read from any angle.

Incorrect LED aiming:

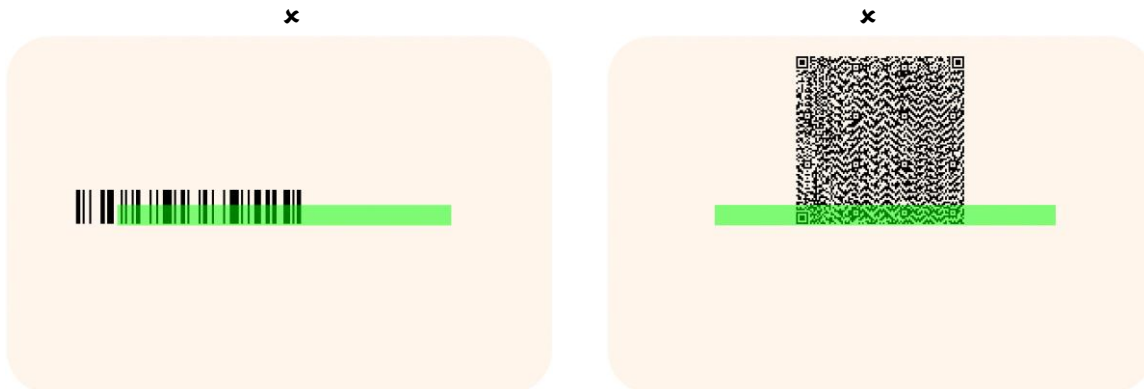

## 2.3 Optional Accessories

### Evaluation Board (MEK-3100)

Use the MEK-3100 evaluation board to:

- Confirm the connection: Connect the MEK-3100 to the imager engine and connect to the host using an RS-232C or USB interface. Observe each signal in the connection.
- Confirm the connection or reading function: Use a terminal emulator or Opticon's "UniversalConfig" for Windows to confirm communication or reading function.
- Evaluate power consumption: Use the MEK-3100 for electricity evaluation, such as imager engine power consumption.



Accessories:

- MEK-3100 interface evaluation board
- FFC (for connecting the imager engine)
- RS-232C cable
- AC adapter (for RS-232C)
- USB cable
- Hardware (such as screws)

### **3 Configuring the MDI-4600 and MDI-4700**

This chapter explains the imager engine configuration, default setting and saving setting, and basic commands.

#### **3.1 [Configuring with Commands](#)**

##### **3.2 [Command Packet Sending Precautions](#)**

##### **3.3 [Custom Command Line Settings](#)**

##### **3.4 [Fast Boot Mode](#)**

##### **3.5 [Basic Commands](#)**

##### **3.6 [Forced Initialization](#)**

## 3.1 Configuring with Commands

The imager engine can be configured by sending commands via the serial interface or by reading 1D or 2D menu labels. This section describes the serial commands.

### 3.1.1 Configuring with a Command Packet

The command packet, from header to terminator, is defined as follows.

Command Header* <sup>2</sup>	Command ID* <sup>1</sup>		Command Terminator* <sup>2</sup>
<ESC> (0x1B)	None	1 - 2 digits (ASCII)	<CR> (0x0D)
	[(0x5B)	3 digits (ASCII)	

\*1 Multiple command IDs can be sent between a single header and terminator, except for single digit IDs.

\*2 A command header <STX>(0x02) can be combined with a terminator <ETX>(0x03).

Input examples:

- 1-digit command                                   <ESC>Δ<CR>
- 2-digit command                                   <ESC>ΔΔ<CR>
- 3-digit command                                   <ESC>[ΔΔΔ<CR>
- Two 2-digit commands                           <ESC>ΔΔΔΔ<CR>
- 2-digit and 3-digit command                   <ESC>ΔΔ[ΔΔΔ<CR>



To send commands, use “UniversalConfig”

Enter the command in the “command:” box with a character string (not ASCII code). Commands entered do not require the beginning command header <ESC> or <CR>. The command or commands are sent to the reader when the ENTER key is pressed or the [Send] button is clicked.

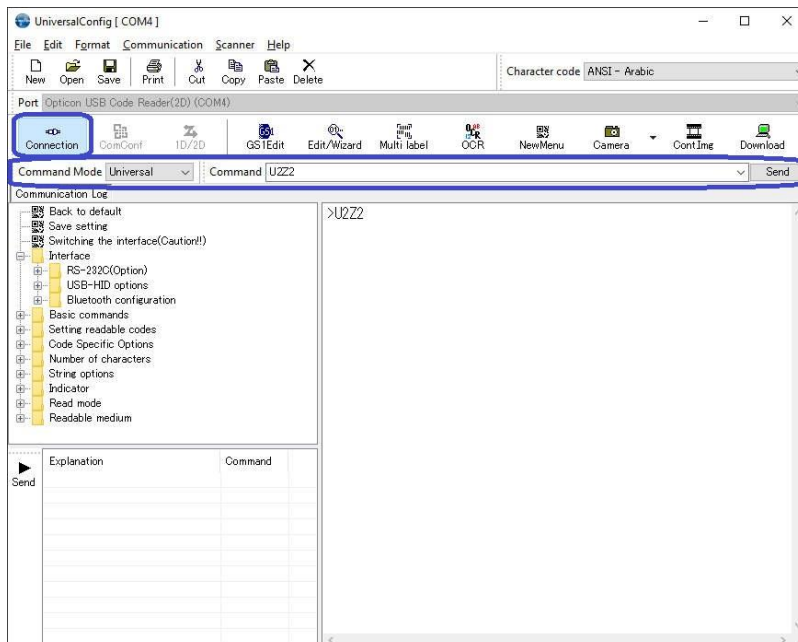

### Command Packet Sending Guidelines

- The maximum length of any command packet is 1000 characters. When more characters than this limit are sent, some characters may be lost and the execution will not be performed correctly.
  - Do not send commands for 30 ms from these timings, because the command may not be received correctly:
    - Start reading (trigger press or send Z command)
    - Start auto trigger
    - Execute save process
    - Start image acquisition function
- Note:** When sending auto trigger enable (+I) or save commands (Z2, [BAQ, [EFY) together with multiple commands in one command packet, the number of commands included in the command packet x 1ms + 30ms
- Any settings configured by commands are not retained in non-volatile memory. So, these settings are lost when the power is turned off. When the power turns back on, the imager engine will be in the configuration state saved in non-volatile memory. To save the settings made with commands, end the string by sending the Z2 command to save all the parameters in non-volatile memory.
  - Communication may be disrupted when Baud rate, Data length, Parity and Stop bit are configured, so they will not be reflected until they are written in non-volatile memory using the Z2 command.
 

**Note:** Settings made by reading 2D or 1D menu codes will be saved in non-volatile memory. Any settings made prior via commands will be saved as well. For help, see [“Configuring with 2D Menu”](#). and [“Configuring with 1D Menu Code”](#).
  - Use the ACK/NAK command to check if the command was executed correctly. For help, see [“ACK/NAK for Serial Commands”](#).

### 3.1.2 Configuring with 2D Menu Codes

A single 2D menu code can contain multiple settings that will be processed in order, in one operation. So, you can configure the imager engine with multiple settings by reading only one 2D menu code. Scanning a 2D menu code always performs a 'save settings' action upon completion, so a Z2 command to save current settings is not needed.

Data Packet:

@MENU\_OPTO@ZZ@MenuCommand 1@MenuCommand 2@ZZ@OTPO\_UNEM@

"@MENU_OPTO"	(Start key)	
"@"	(Separator)	
"ZZ"	(Start menu)	
"@"	(Separator)	← Multiple sets allowed
"Any menu command"	(U2 etc)	
"@"	(Separator)	
"ZZ"	(END menu)	
"@"	(Separator)	
"OTPO_UNEM@"	(Stop key)	



Use "UniversalConfig" to create a 2D menu code.

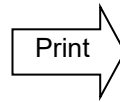
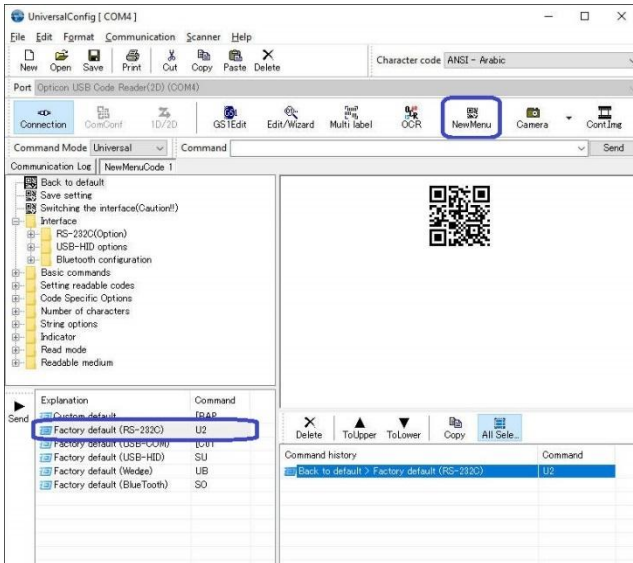

\*To order "Universal Config," contact your local sales office.

### 3.1.3 Configuring with 1D Menu Codes

By scanning a series of 1D menu codes specifically designed to configure the required functions, you can set up the imager engine to optimize its performance for your particular application.

The basic procedures are as follows:

Scan SET menu code (ZZ). The imager engine now enters menu mode.



Scan one or more desired options.

Multiple menu codes can be read when you want to configure more than one option.



Read END menu code (ZZ). All the settings are saved in non-volatile memory.

\* 1D menu codes encode an ID consisting of two to three alphanumeric characters. 1D menu codes are Code 39 labels with modified start/stop characters, so the imager engine will not acknowledge a 1D menu code as a normal barcode.

Use “UniversalConfig” to create a 1D menu code.

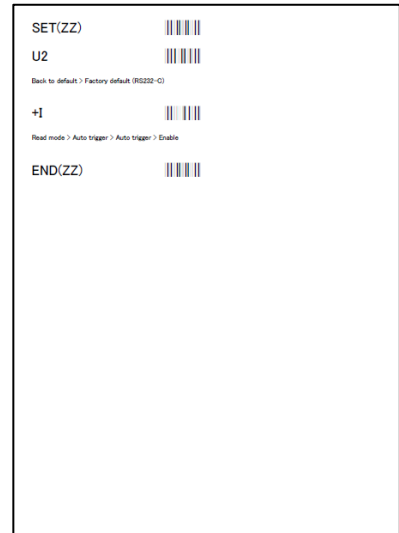
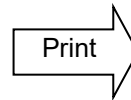
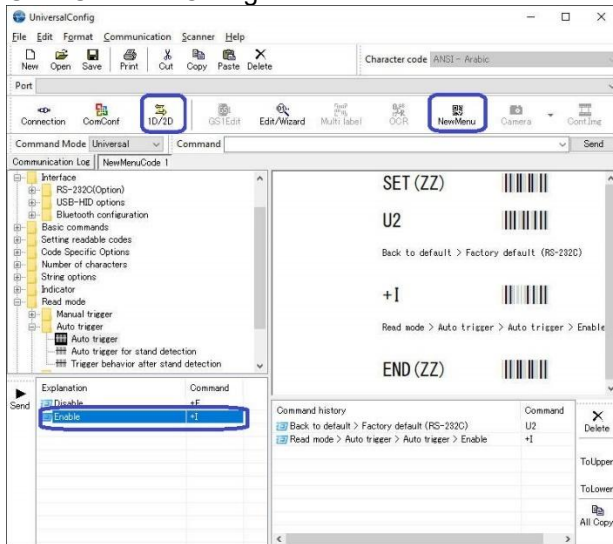

\* To order “Universal Config,” contact your local sales office.

## 3.2 Command Packet Sending Precautions

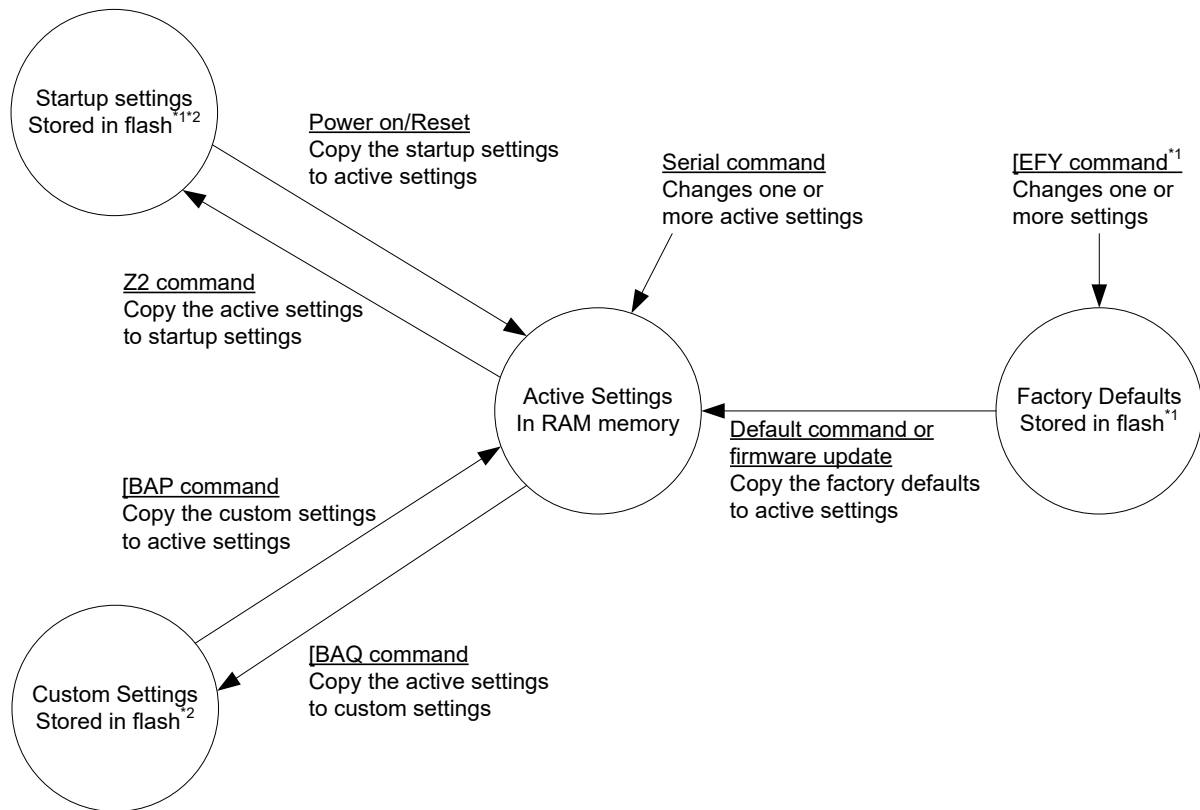

\*1 Only configures the factory defaults in an environment where power is stable.

\*2 These regions maintain the settings when a firmware update is loaded for firmware.

\*3 They can be rewritten up to 30,000 times

Setting	Description
Active Settings	Active Settings are an area contained in RAM memory, so they are lost after a power cycle. This area contains the currently active settings, so the imager engine is operating based on these settings. These settings are loaded from one of the other areas, and also contain new settings added via serial commands or menu labels.
Startup Settings	Startup Settings are an area in non-volatile memory. The data here is copied to the Active Settings area in RAM when the imager engine is powered up.
Custom Settings	Custom Settings are an area in non-volatile memory. The data here is copied to the Active Settings area in RAM when the [BAP command is sent to the imager engine. This area is overwritten with the current Active Settings when reading or sending the command "[BAQ".
Factory Default Settings	Factory Default Settings is an area in non-volatile memory. These are the default settings for the imager engine that are loaded into the Active Settings area when the default command (U2) is read or sent. Factory Default Settings can be modified using Custom Command Line Settings. For help, see " <a href="#">Custom Command Line Settings (Change the Factory Default Settings)</a> ".

### 3.2.1 Interface Default Setting

The Active Settings can be returned to the factory default settings. Set the command that corresponds to the interface being used.

#### Factory Default Setting Commands

Command	Interface	Description
U2	UART	Restore UART to factory default settings
[C01	USB-COM	Restore USB-COM to factory default settings
SU	USB-HID	Restore USB-HID to factory default settings

### 3.2.2 Save Settings

The Active Settings can be written into the “Startup Settings”.

#### Save Settings Commands

Command	Description	Notes
Z2	Save the Active Settings as Startup Settings	Command only

\* Add “Z2” to the end of the command packet to be saved.

\* Saving settings more than 30,000 times may destroy memory. Avoid saving every time.

\* Some options (like baud rate) will not be enabled until “Save settings” is sent.

### 3.2.3 Custom Settings

#### Custom Settings Commands

Command	Description
[BAP	Read out Custom Settings
[BAQ	Save to Custom Settings

\* Add “[BAQ” to the end of the command packet to be saved.

\* To save both “Custom Settings” and “Active Settings” at same time, send “[BAQZ2”.

\* Saving Custom Settings more than 30,000 times may destroy memory. Avoid saving every time.

### 3.3 Custom Command Line Settings (Change the Factory Default Settings)

The Factory Default Settings the imager engine was shipped with can be permanently changed via Custom Command Line commands. These settings will even persist through a firmware update. The new Factory Default Settings become active after a reboot and initialization of the imager engine.

**Note:** Be careful with Custom Command Line commands, because they may corrupt the flash memory when the power is turned off during the setting operation. Only use these commands in an environment where the power is stable.

These settings are suggested for Custom Command Line Settings:

- Image settings. For help, see “[Image Settings](#)” .
- Baud rate, Data length, Parity, Stop bit etc. For help, see “[UART](#)”.

Command Header	Command	Separator	Command IDs <sup>(*)</sup>	Separator	Command Terminator
<ESC>	[EFY	,	Custom Commands	,	<CR>
		(0x27)		(0x27)	

\*1 Multiple commands allowed.

To activate the new Factory Defaults, the “RV” command must be sent or scanned, which will reset the imager engine. To load the new Factory Defaults, send or scan the U2 command to save the new settings so that they will be loaded after a power up.

Sample Custom Command Line Settings:

- Set “ACK/NAK” enable: “WC”
- Set “2D Menu Code” disable: “[D1Z”
- Set “Upside Down Image” enable: “[EFV[E8I”
- Set “Baud rate” to 115200 bps: “SZ”
- Set “Low Power standby” enable: “[EB8”
- Set “Low Power standby Transition Time” to 2 seconds: “[EBAQ0Q0Q0Q2”
- Reboot the imager engine: “RV”
- Initialize the imager engine: “U2”

Example of packets sent to configure Custom Command Line Settings:

```
<ESC>[EFY'WC[D1Z[EFU[E8ISZ[EB8[EBAQ0Q0Q0Q2'<CR>
<ESC>RV<CR>
<ESC>U2Z2<CR>
```

#### Output Configured Custom Command Line Commands

Currently configured commands in Custom Command Line Settings can be output.

Type of Commands	Command	Description
Output Commands	[EFZ	Output configured commands in custom command line

Example of output

```
[EFXQ1WC[D1Z[EFU[E8ISZ[EB8[EBAQ0Q0Q0Q2
```

**Note:** The imager engine will not send anything if no Custom Command Line commands have been configured.

### 3.4 Fast Boot Mode

In the MDI-40x0 and MDI-41x0, fast boot mode shortens the boot time. But, the MDI-4600 and MDI-4700 have a faster normal boot mode, so fast boot mode has no effect.

When fast boot mode is enabled, all settings saved with the “Z2” command are ignored and the imager engine starts with the default settings. For help, see “[Interface Default Setting](#)”. The default settings can be changed with Custom Command Line commands. For help, see “[Custom Command Line Settings \(Change the Factory Default Settings\)](#)”.

Configuration	Command	Description	Default
Fast Boot Mode Enable/Disable	[EFX	Get the current mode (*)	
	Q0	Disable Fast Boot Mode	✓
	Q1	Enable Fast Boot Mode	

\*Return values:  
 Disable Fast Boot Mode<CR>  
 Enable Fast Boot Mode<CR>

#### Boot Time Specification

(IF:UART/USB, VCC = 3.3V, 5.0V TA = 25°C)

Mode	Description	Min.	Typ.	Max.	Unit
Normal Boot	Time taken to be ready after supplying the power	-	360	1000	ms
Fast Boot					

This illustration shows the transition diagram in fast boot mode.

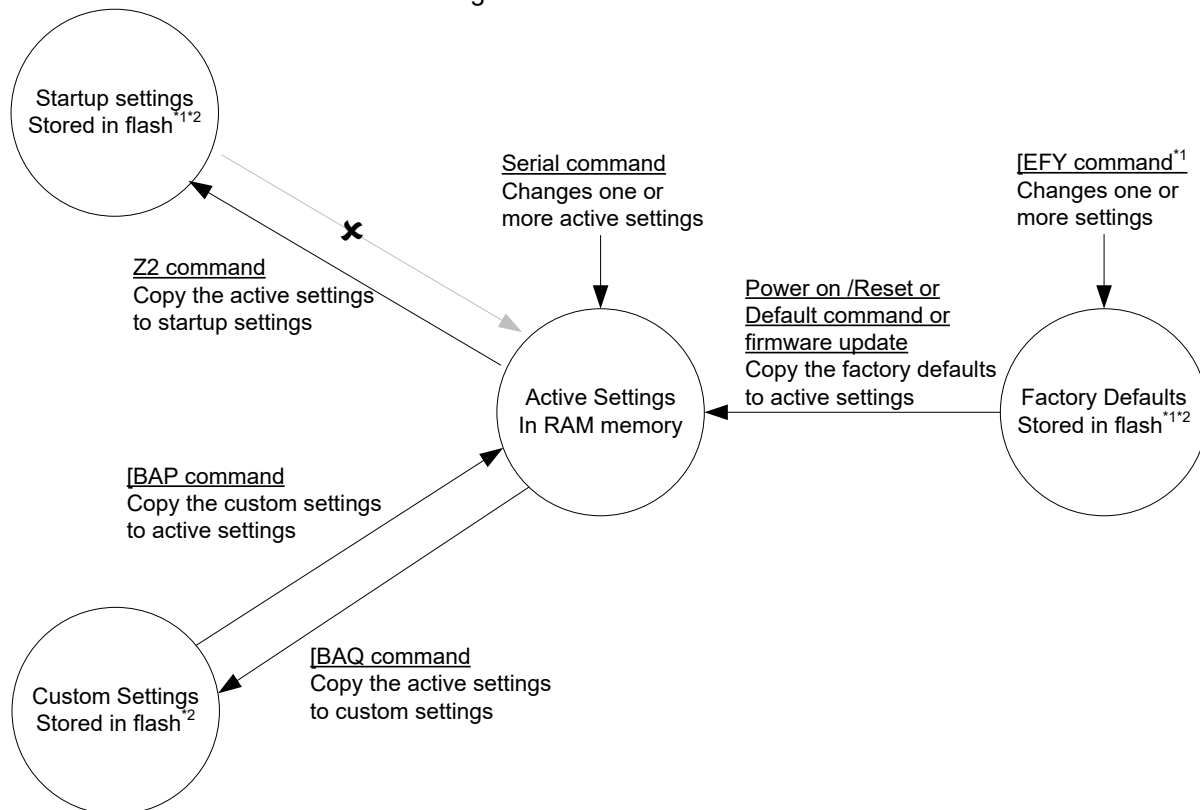

\*1 Only configures the factory defaults in an environment where power is stable.

\*2 These areas are erased when a firmware update is loaded depending on the firmware version, and can be rewritten up to 30,000 times.

## 3.5 Basic Commands

### 3.5.1 Trigger Command

The reading operation can be started and terminated by sending commands. When the read cycle timeout is set to 0 seconds (Y0 command), the read time with the Z command is 'Indefinitely' and reading will continue until a Y command is received. For timeout limited reading, use the Yx commands. For help, see "[Read Timing](#)".

#### Trigger Commands

Command	Description	Notes
Z	Start the read cycle	Command only
Y	Stop the read cycle	

#### Add New Software Trigger Command

In addition to the Z and Y trigger commands, a new command using any character string to start/stop the read cycle can be added.

#### Set Character String for the Command to Start/Stop the Read Cycle

Command	Description	Default	
[EHK	Available characters	Set the start read cycle command by entering the [EHK command followed by the ASCII command.	None
	ASCII (*)		
	0 – 32 characters		
[EHL	Available characters	Set the end read cycle command by entering the [EHL command followed by the ASCII command.	None
	ASCII (*)		
	0 – 32 characters		

Notes:

- NULL, STX, ETX, CR, and ESC cannot be set.
- Even if new software trigger commands are added, the "Z" and "Y" trigger commands will always function.
- To clear the start read cycle command character string, set only [EHK without an ASCII command.
- To clear the end read cycle command character string, set only [EHL without an ASCII command.

The command string with the previous settings can also be executed without the command header (ESC or STX) or command terminator (CR or ETX).

#### Execute With or Without Command Header or Terminator

Command	Description	Default	
[EHN	Q0	Execute without command header or terminator.	
	Q1	Execute with command header or terminator.	✓

#### Example Setting 1

Start the read cycle "<ESC>STR<CR>", stop the read cycle "<ESC>STP<CR>"

Command: [EHK0S0T0R[EHL0S0T0P

#### Example Setting 2

Start the read cycle "E", stop the read cycle "D"

Command: [EHK0E[EHL0D[EHNQ0

### 3.5.2 Diagnostic Commands

These commands can be used to get diagnostics information from the imager engine.

#### Diagnostics Commands

Command	Description	Notes
Z1	Transmit software version	
Z3	Transmit settings	*
[EAR	Transmit only changes from default	
ZA	Transmit ASCII printable string	
YV	Transmit ASCII control string	

\* The Z3 output result is subject to change when the firmware version is changed.

#### Device Information Commands

Command	Description	Example	Possible Values	
[EFK	Q0	Model Number	MDI-4700	MDI-4600, MDI-4700
	Q1	Firmware Version	BJ01J01	BJ01Jxx, where xx=revision number.
	Q2	Interface	U2	U2 = Serial Standard I/F mode U* = Serial S-Mode I/F mode SU = USB (HID/Keyboard) I/F mode C01 = USB-Virtual COM I/F mode
	Q3	Focus type	SR	SR = Standard Range (115 mm fixed focus) HD = High Density (65 mm fixed focus) UD = Ultra-High Density (45 mm fixed focus)
	Q4	ID (32 digits)	765987D894C A53918218FB0 D31A54AAF	Unique number for every imager engine
	Q5	Serial number	1000001	Serial number of the imager engine

### 3.5.3 ACK/NAK for Serial Commands

When "ACK/NAK for serial commands" is enabled, the imager engine sends an ACK (0x06) when a command is received and accepted, and a NAK (0x15) when a command is rejected.

#### ACK/NAK Commands

Command	Description	Default
WC	Enable ACK/NAK for serial commands	
WD	Disable ACK/NAK for serial commands	✓

The next diagram illustrates the ACK/NAK response.

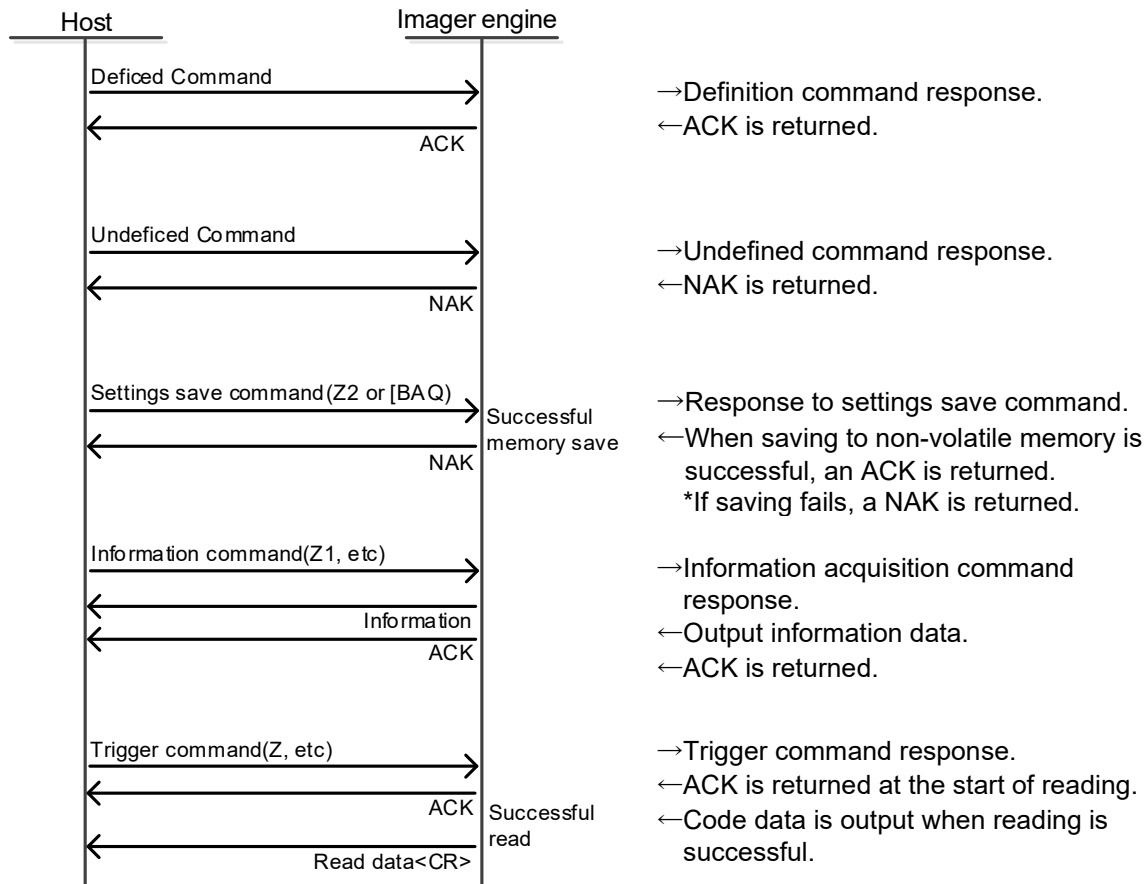

### 3.5.4 Reboot the Imager Engine

Use this command to restart the imager engine.

**Note:** The “Custom Factory Default Settings” operation requires a reboot.

#### Software Reboot Command

Command	Description
RV	Reboot the imager engine

### 3.5.5 Enable/Disable 2D Menu Codes

Use these commands to enable or disable processing 2D menu codes. If 2D menu codes are not being used, they should be disabled.

#### Enable/Disable 2D Menu Codes Commands

Command	Description	Default
[D1Y	Enable 2D menu code	✓
[D1Z	Disable 2D menu code*	

\* Disable indicates that 2D menu codes will be read as normal 2D codes. When reading is successful, 2D menu code data is output.

### 3.5.6 Enable/Disable 1D Menu Code

Use these commands to enable or disable decoding 1D menu codes. If 1D menu codes are not used, they should be disabled.

#### Enable/Disable 1D Menu Codes Commands

Command	Description	Default
[DFB Q0 Q1	Enable 1D menu code when using TRIGn signal.	✓
Q0 Q0	Disable 1D menu code when using TRIGn signal.*	
Q2 Q1	Enable 1D menu code when using software trigger.	
Q2 Q0	Disable 1D menu code when using software trigger.*	✓

\* Disable indicates that 1D menu codes will not be read.

### 3.5.7 Image Settings

When the imager engine is mounted upside down, it should rotate the sensor data by 180°. This configuration is required, especially for image acquisition and OCR reading.

When an external mirror is installed in front of the imager engine, the imager engine should mirror the sensor data. Two options are available for that, horizontal mirror and vertical mirror.

#### Horizontal and Vertical Mirrored Image Commands

Mirrored Image Orientation	Command	Description	Default
Horizontal mirrored image	[EFU	Disable horizontal mirrored image configuration	✓
	[EFV	Enable horizontal mirrored image configuration	
Vertical mirrored image	[E8J	Disable vertical mirrored image configuration	✓
	[E8I	Enable vertical mirrored image configuration	

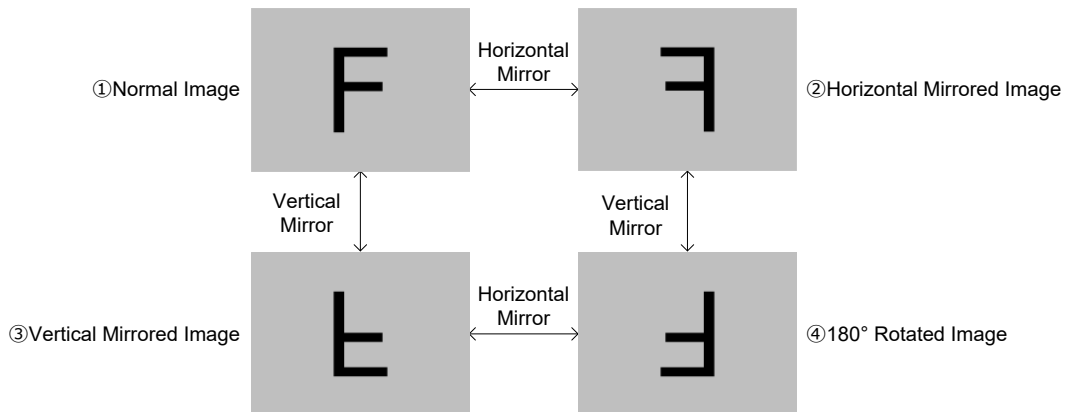

#### Horizontal and Vertical Mirrored Image Style Commands

Style	Commands	Horizontal Mirror	Vertical Mirror
Normal image	[EFU][E8J	Disable	Disable
Horizontal mirror image	[EFV][E8J	Enable	Disable
Vertical mirror image	[EFU][E8I	Disable	Enable
180° rotated image	[EFV][E8I	Enable	Enable

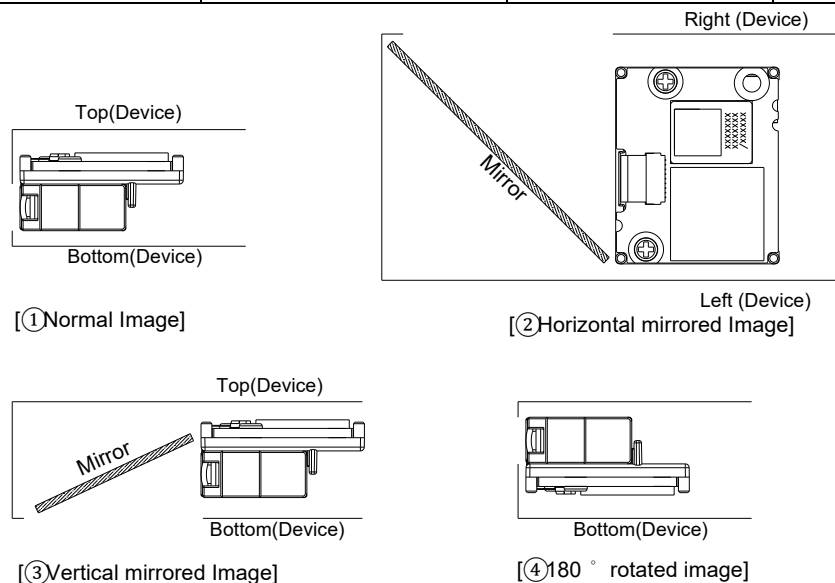

### 3.5.8 Disable Reading Operation

Use these commands to enable or disable reading. Auto trigger and TRIGn signal becomes invalid if reading is disabled. In this setting, menu labels cannot be read, only commands via serial communication are supported.

#### Enable or Disable Reading Operation Commands

Command	Description	Default	Notes
[EAT	Enable module reading operation	✓	Command only
[EAU	Disable module reading operation		Command only

### 3.5.9 Buzzer and Indicator

These commands are described in “[Buzzer \(BUZZERn Signal\)](#)” and “[Good Read LED \(GR\\_LEDn Signal\)](#)”.

#### Buzzer and Indicator Commands

Buzzer or LED	Command	Description	Notes
BUZZERn	B	Send the confirm buzzer signal from BUZZERn.	Command only
	E	Send the error buzzer signal from BUZZERn.	
GR_LED	L	Flash the GR_LEDn	

### 3.5.10 Direct Numerical Input Command

Use these commands when a command requires additional numerical input. Add these commands to one packet with the command that requires the numerical input.

#### Direct Input Numerical Values Commands

Command	Description	Notes
Q0	0	Input in a specified format
Q1	1	
Q2	2	
Q3	3	
Q4	4	
Q5	5	
Q6	6	
Q7	7	
Q8	8	
Q9	9	

### **3.6 Forced Initialization**

---

If the scanner is unable to read barcodes, use this recovery method.

To force initialization:

1. Turn off the imager engine.
2. Turn on the power while keeping TRIGn Low.
3. Wait for at least 10 seconds. TRIGn becomes active and the imager engine should be able to read barcodes.

## 4 Interface Options

The Imager engine support USB-COM, USB-HID and UART interface. This chapter explains each interface in detail.

### 4.1 [UART](#)

### 4.2 [USB-COM](#)

### 4.3 [USB-HID](#)

### 4.4 [Common Settings](#)

## 4.1 UART

---

This chapter explains UART interface settings.

- 4.1.1 [Switch the Interface to UART](#)
- 4.1.2 [UART Interface Signal](#)
- 4.1.3 [UART Basic Information](#)
- 4.1.4 [Baud Rate \(Transfer Speed\)](#)
- 4.1.5 [Character Format](#)
- 4.1.6 [Handshaking \(Flow Control\)](#)
- 4.1.7 [Inter Character Delay \(UART\)](#)
- 4.1.8 [Trouble Shooting \(UART\)](#)

### 4.1.1 Switch the Interface to UART

To switch the interface from USB to UART from USB, send a command or read a 2D menu Code. When using the UART interface, make sure the 12-pin FFC cable is connected to UART signals.

**Caution: UART is a standard factory default setting. If the host side is USB, communication will fail.**

**Note:** This setting will persist through a firmware update.

#### Change Interface to UART

Command	Menu Code
[X.ZU2[X.ZZ2	 @MENU_OPTO@ZZ@X.Z@U2@X.Z@ZZ@OTPO_UNEM@

### 4.1.2 UART Interface Signal

An IRISO Electronics co. .ltd 9681-12(12-PIN) (bottom contact) equivalent connector is used.

No.	Name	Function	I/O	Conditions	State	Notes
1	TRIGn	Trigger	In		L: Start operation H: No action	100kΩ pull up on imager engine
2	AIM/WAKEn	Recovery signal from Low Power state	In		L: Recover from low power state H: No action	100kΩ pull up on imager engine
		Aiming control signal in states other than Low Power	In		L: Aiming LED on H: Aiming LED off	
3	GR_LEDn	Good read LED	Out		L: LED on H: LED off	4.7kΩ pull up on imager engine
	EX_ILLUM	Control of an external light source.	Out	Configured*1	L: External Illumination On H: External Illumination Off	
4	BUZZERn	Buzzer	Out			A transistor or FET should be used to drive a buzzer.
5	POWERDWN	Indicates Low Power state	Out		L: Normal state H: Low Power state	100kΩ pull up on imager engine
6	RTS	Communication control signal to host system	Out			10kΩ pull up on imager engine
7	CTS	Communication control signal from host system	In			100kΩ pull up on imager engine
8	TxD	Transmitted data signal	Out			10kΩ pull up on imager engine
9	RxD	Received data signal	In			100kΩ pull up on imager engine
10	GND	System ground				
11	V <sub>CC</sub>	Power input	In		3.3V or 5.0V	
12	Reserve		In			N.C

\*1 When this signal is set, Good Read LED cannot be used.

\*2 Tone/sound pressure is adjustable by using the Pulse Width Modulation (PWM) signal.

### 4.1.3 UART Basic Information

#### Basic UART Parameters

Parameter	Value	Default
Transfer speed	300 to 921600 bps	9600 bps
Data length	7 bits, 8 bits	8 bits
Parity bit	None, Even, Odd	None
Stop bit	1 bit, 2 bits	1 bit
Handshaking (Flow control,)	None, BUSY/READY, Modem, ACK/NAK	None
Inter Character Delay	No delay, 20 ms, 50 ms, 100 ms	No delay

#### 4.1.4 Baud Rate (Transfer Speed)

The baud rate is the rate at which bits are transmitted from the imager engine to the host and vice versa. Both the reader and the host must be set to the same baud rate.

To activate and save the new configuration, you need to use the Z2 command (save settings in non-volatile memory).

**Note:** You should configure these settings at “Custom Factory Default.”

#### Baud Rate Commands

Command	Description	Default
K1	300 bps	
K2	600 bps	
K3	1200 bps	
K4	2400 bps	
K5	4800 bps	
K6	9600 bps	✓
K7	19200 bps	
K8	38400 bps	
K9	57600 bps	
SZ	115200 bps	
[D90	230400 bps	
[D91	460800 bps	
[D92	921600 bps	

### 4.1.5 Character Format

The data characters are transferred in the format shown below. A parity bit is added to every character so that the total number of 1's in the data bits, together with the parity bit, is odd for odd parity and even for even parity.

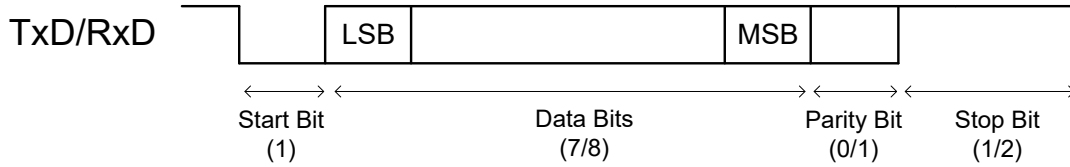

After setting Data Bits, Parity, and Stop Bits, use the Z2 command (save settings in non-volatile memory) to activate and save the new configuration.

#### Data Bits, Parity, and Stop Bits

Parameter	Command	Description	Default
Data Bits	L0	7 data bits	
	L1	8 data bits	✓
Parity	L2	No parity	✓
	L3	Even parity	
	L4	Odd parity	
Stop Bits	L5	1 stop bit	✓
	L6	2 stop bits	

### 4.1.6 Handshaking (Flow Control)

Use Handshaking commands to set the communication control method. After setting Handshaking, use the Z2 command (save settings in non-volatile memory) to activate and save the new configuration.

#### Handshaking Commands

Command	Description	Default
P0	No handshaking	✓
P1	Busy/Ready	
P2	Modem	
P3	ACK/NAK	
P4	ACK/NAK NO RESPONSE	

### No Handshaking

The imager engine communicates regardless of the state of the host system. With no handshaking, commands from the host system may not be received correctly.

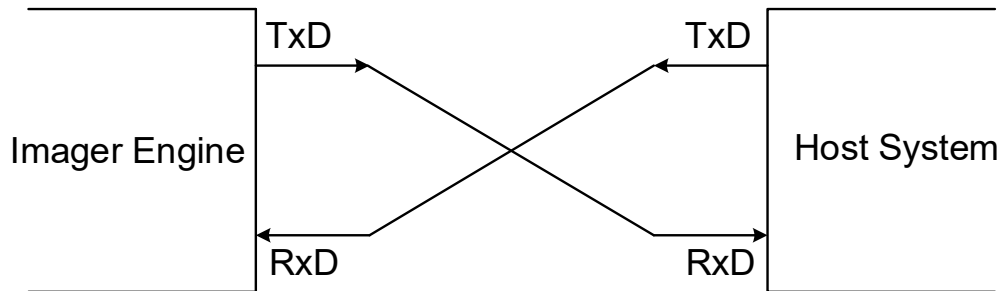

### Busy/Ready

The imager engine and the host system notify each other when they are ready to receive data (Busy/Ready) via their RTS line. When they are connected as shown in the next illustration, the CTS line can be used to check if the other side is busy (off) or ready to receive data (on).

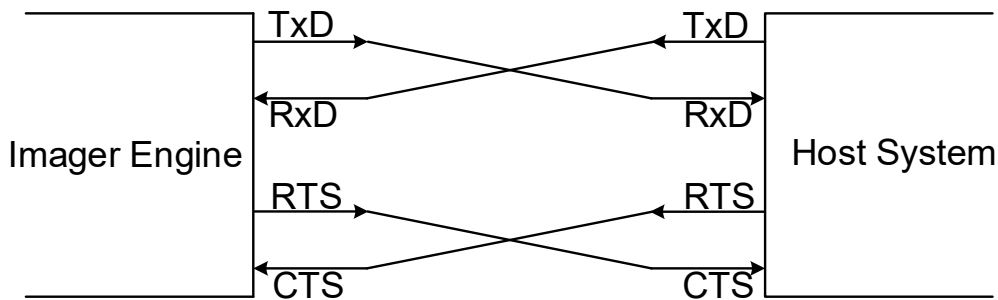

The imager engine's RTS is normally on (ready to receive data) except during the processing of received data, while transmitting data, and while it is busy processing 1D or 2D menu codes. When the imager engine wants to send data, the imager engine checks if its CTS line is on (host is ready to receive data). If the CTS line is off, the imager engine does not send the data but waits for a specific timeout period for the CTS line to be turned on. If the CTS line is not turned on within the specified time, the data transmission is aborted.

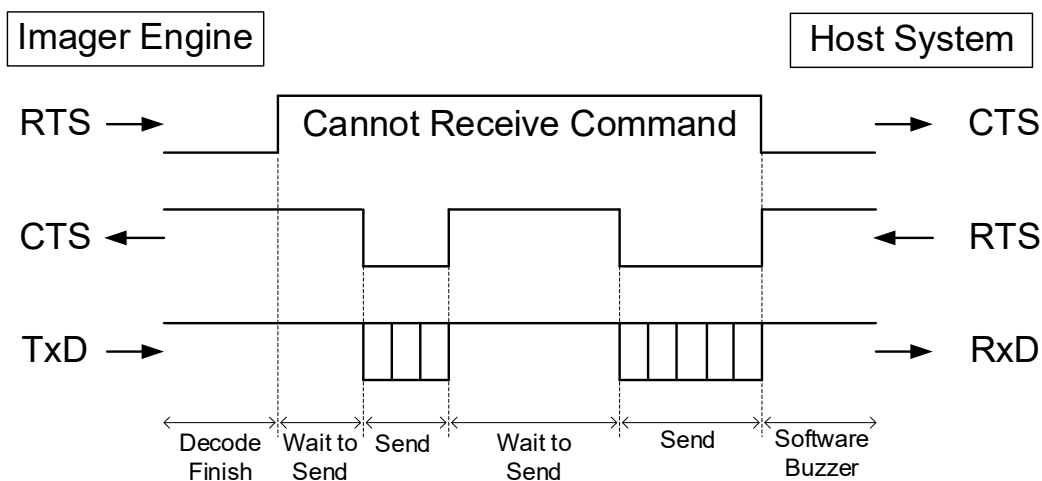

### <CTS, TxD Signal Timing>

When the CTS line (RTS signal on the host side) is turned off during a TxD signal transmission, the imager engine stops the transmission. When the CTS signal is turned on during signal transmission, characters will be transmitted.

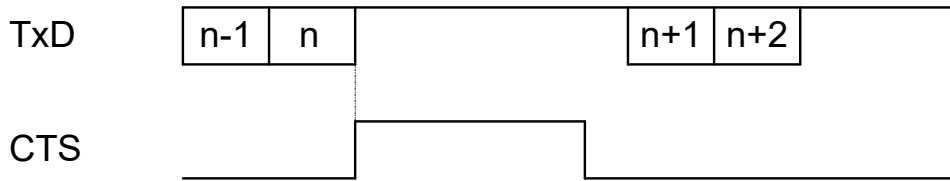

After setting CTS Timeout, use the Z2 command (save settings in non-volatile memory) to activate and save the new configuration.

### CTS Timeout Commands

Command	Description	Default
I0	Flow Control timeout: Indefinitely	✓
I1	Flow Control timeout: 100 ms	
I2	Flow Control timeout: 200 ms	
I3	Flow Control timeout: 400 ms	

### Modem

The imager engine's RTS is OFF as soon as power is supplied to the imager engine. The imager engine will turn RTS ON when it wants to transmit data to the host. The host should respond with CTS ON when it is ready to receive data. While the host CTS is ON, the imager engine is allowed to transmit data. When all data has been transmitted, the imager engine will turn RTS OFF. In response, the host should turn OFF the imager engine's CTS. If, while RTS is ON, the CTS line is not ON for a certain configurable amount of time, the imager engine will terminate the transmission with a buzzer error.

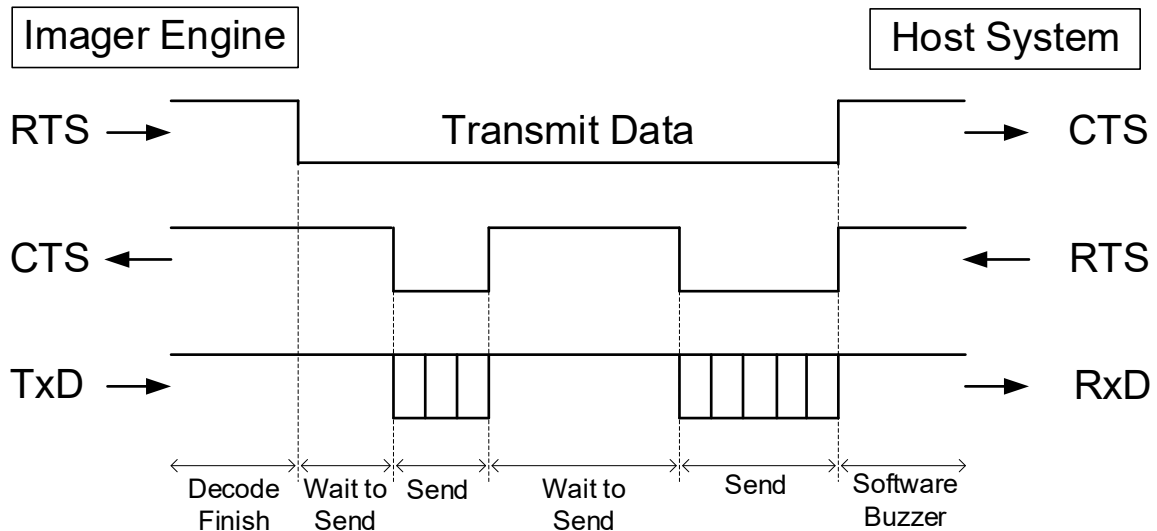

### ACK/NAK Control

In ACK/NAK mode, the imager engine transmits data and expects to receive a specific response from the host.

### ACK/NAK Host Responses

Response	Description
"ACK" (ASCII:0x06)	The imager engine terminates transmission with the good read sound.
"NAK" (ASCII:0x15)	The imager engine sends the data again.
"DC1" (ASCII:0x11)	The imager engine terminates transmission without the good read or error sound.
Timeout	If there is no response within 1 second, the imager engine terminates transmission with the error sound.

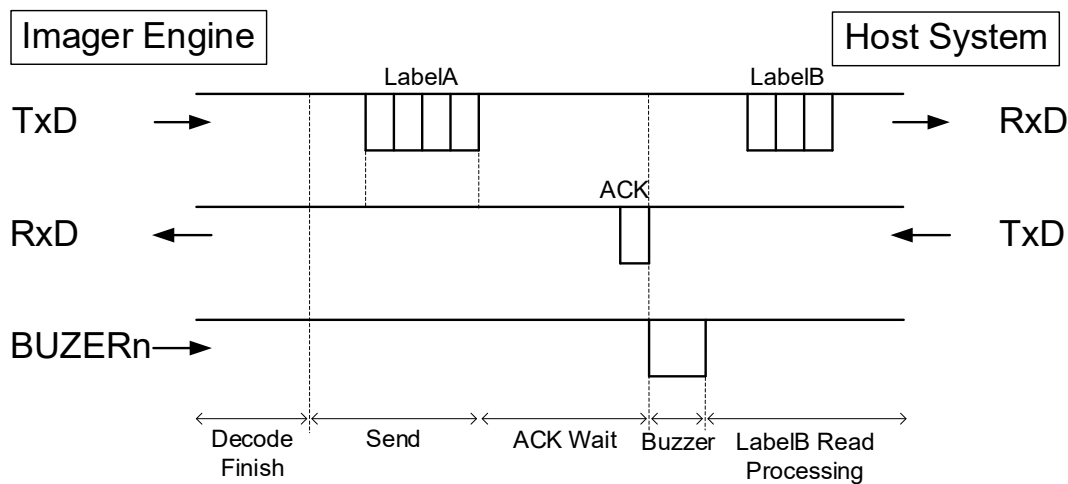

### <ACK/NAK Flow Chart>

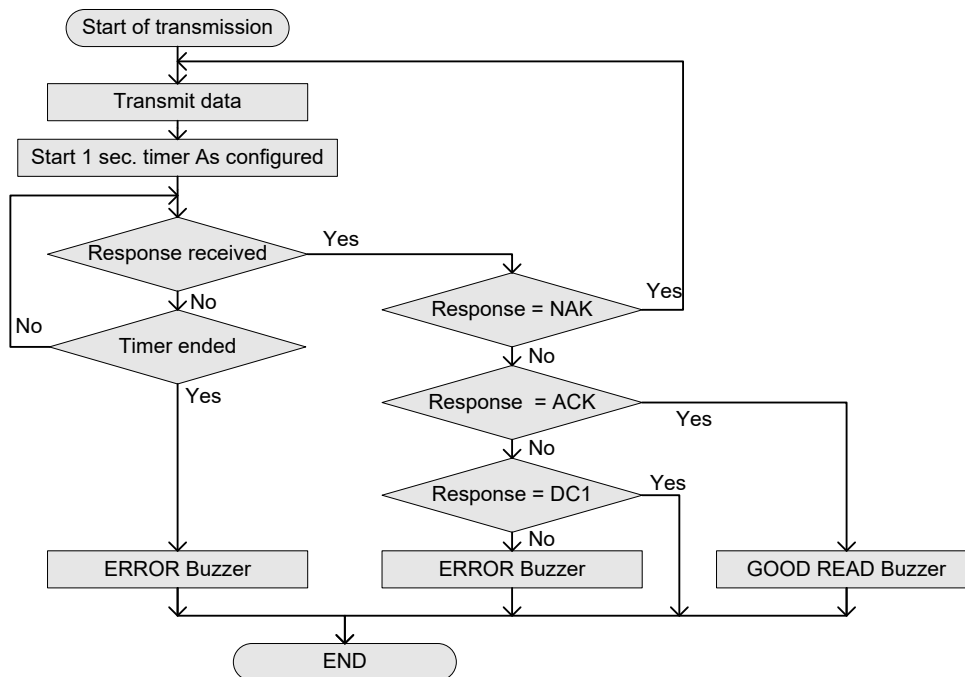

### ACK/NAK Timeout Commands

Command	Description	Default
[XI4]	ACK/NAK timeout: Indefinitely	
[XI5]	ACK/NAK timeout: 100 ms	
[XI6]	ACK/NAK timeout: 500 ms	
[XI7]	ACK/NAK timeout: 1s	✓

### ACK/NAK No Response

ACK/NAK No Response is different from ACK/NAK mode in that if no response is received from the host within 100 ms, the imager engine assumes that the data has been successfully received by the host.

### ACK/NAK No Response Host Responses

Response	Description
"ACK" (ASCII:0x06)	The imager engine terminates transmission with the good read sound.
"NAK" (ASCII:0x15)	The imager engine sends the data again.
"DC1" (ASCII:0x11)	The imager engine terminates transmission without the good read or error sound.
Timeout	If there is no response within 100 ms, the imager engine terminates transmission with the good read sound.

### <ACK/NAK No Response Flow Chart>

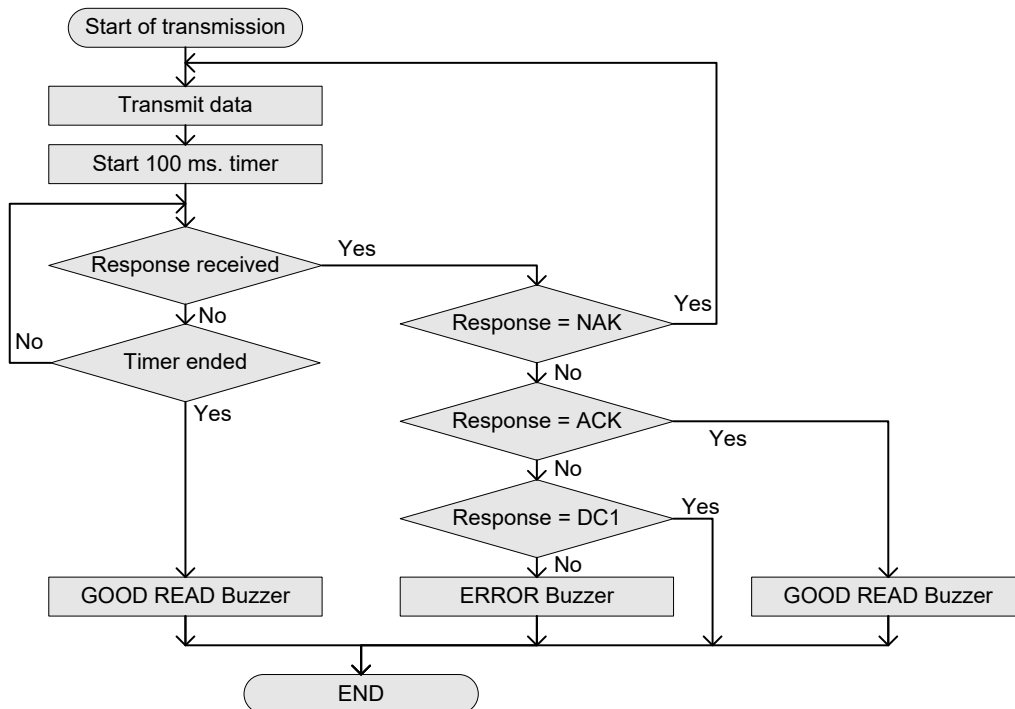

### 4.1.7 Inter Character Delay (UART)

The inter character delay introduces a configurable delay after each transmitted character. This may be used if the host does not support flow control and is not capable of handling the received data.

After setting Inter Character Delay, use the Z2 command (save settings in non-volatile memory) to activate and save the new configuration.

#### Inter Character Delay Commands

Command	Description	Default
KA	No delay	✓
KB	20 ms delay	
KC	50 ms delay	
KD	100 ms delay	

### 4.1.8 Troubleshooting UART

Use this table to find possible solutions to common UART problems.

Problem	Possible Solution
Cannot communicate No response when sending command	<ul style="list-style-type: none"> <li>• Verify the communication settings.</li> <li>• After changing communication setting, make sure to send the Z2 command.</li> <li>• Verify Handshaking. For help, see "<a href="#">Handshaking (Flow Control)</a>".</li> </ul>
Garbled characters	<ul style="list-style-type: none"> <li>• Verify the communication settings.</li> <li>• Make sure the barcode you are trying to read matches the character code of the communication tool.</li> </ul>
Line-break is doubled	Check the line break setting of the communication tool.

## 4.2 USB-COM

---

This chapter explains USB-COM interface related settings.

- 4.2.1 [Switching the Interface to USB-COM](#)
- 4.2.2 [USB Interface Signal](#)
- 4.2.3 [USB-COM Basic Information](#)
- 4.2.4 [Integration \(USB driver\)](#)
- 4.2.5 [USB-COM Connection Confirm](#)
- 4.2.6 [Fixed USB-COM Port](#)
- 4.2.7 [Connection Method](#)
- 4.2.8 [COM to HID Output \(WIME\)](#)
- 4.2.9 [Trouble shooting \(USB-COM\)](#)

### 4.2.1 Switch the Interface to USB

To switch the interface from UART or USB-HID to USB-COM, send a command or read a 2D menu code. When using the USB-COM interface, make sure the 12-pin FFC cable is connected to USB signals.

**Caution:** UART is a standard factory default setting. If the host side is USB, communication will fail.

**Note:** This setting will persist through a firmware update.

#### Change Interface to USB-COM

Command	Menu Code
[X.Z[C01[X.ZZ2	 <p data-bbox="477 730 884 750">@MENU_OPTO@ZZ@X Z@C01@X Z@ZZ@OTPO_UNEM@</p>

#### 4.2.2 USB Interface Signal

An IRISO Electronics co. .ltd 9681-12(12-PIN) (bottom contact) equivalent connector is used.

No.	Name	Function	I/O	Conditions	State	Notes
1	TRIGn	Trigger	In		L: Start operation H: No action	100kΩ pull up on imager engine
2	AIM/WAKEn	Recovery signal from Low Power state	In		L: Recover from low power state H: No action	100kΩ pull up on imager engine
		Aiming control signal in states other than Low Power	In		L: Aiming LED on H: Aiming LED off	
3	GR_LEDn	Good read LED	Out		L: LED on H: LED off	4.7kΩ pull up on imager engine
	EX_ILLUM	Control of an external light source.	Out	Configured*1	L: External Illumination On H: External Illumination Off	
4	BUZZERn	Buzzer	Out			A transistor or FET should be used to drive a buzzer.
5	POWERDWN	Indicates Low Power state	Out		L: Normal state H: Low Power state	100kΩ pull up on imager engine
6	RTS	Communication control signal to host system	Out		Set to Open	10kΩ pull up on imager engine
7	USB+	Communication control signal from host system	In/Out			
8	TxD	Transmitted data signal	Out		Set to Open	10kΩ pull up on imager engine
9	USB-	Received data signal	In/Out			
10	GND	System ground				
11	Vcc	Power input	In		3.3V or 5.0V	
12	Reserve		In			N.C

\*1 When this signal is set, Good Read LED cannot be used.

\*2 Tone/sound pressure is adjustable by using the Pulse Width Modulation (PWM) signal.

### 4.2.3 USB-COM Basic Information

#### Basic USB-COM Parameters

Parameter	Description	Notes
Transfer Speed	Full Speed USB 2.0 (FS mode)	
Required power supply capability	500 mA	Actual current value is different.
Vendor ID	065A	
Product ID	A002	
Suspend mode Remote wakeup	Used when the host system is using suspend.	Default: Valid
Other	CDC-ACM compliance	
Fixed COM number	Fixing the COM number is possible.	Default: not fixed

### 4.2.4 Integration (USB driver)

A USB driver is required to connect to the PC via the USB-COM interface. Download the USB driver from the Opticon website, and follow the instructions to install the driver.

### 4.2.5 USB-COM Connection Confirmation

For a USB-COM interface, the connection needs to be confirmed the connection by following procedure.

To install the Opticon USB driver (Windows 10):

1. Connect the imager engine to the PC.
2. Right-click the Windows icon and select **Device Manager**.
3. Open "Ports(COM & LPT)".

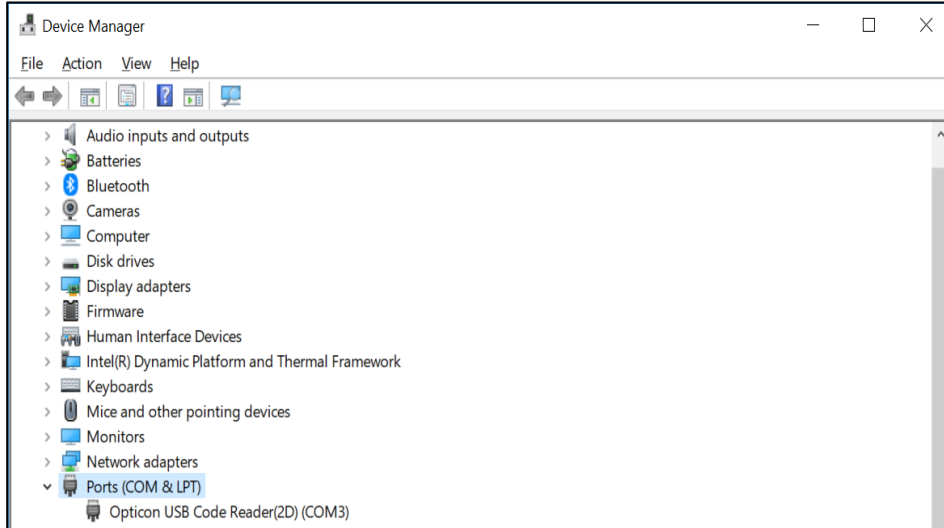

### 4.2.6 Fixed USB-COM Port

You can set whether to fix or not fix the USB-COM port number assigned when the imager engine is connected to a Windows PC. For changes to this setting to take effect, restart the imager engine after saving the settings. When you change and save the settings and reboot, a different COM port number is assigned.

#### Fixed USB-COM Port Number and Driver Selection Command

Command	Description	Default
[EGC] Q0	Not to fix assigned COM port number	✓
Q1	Fix assigned COM port number	

\* Fixed USB-COM Port settings will become active after a reboot and initialization of the imager engine.

When the imager engine is connected to a Windows PC, the Windows OS assigns an unused port number to the USB-COM port number when the imager engine is connected for the first time. The default setting of "Not to fix assigned COM port number" assigns a different port number to each USB port regardless of the imager engine.

When set to "Fix assigned COM port number", the Windows OS recognizes the imager engine and assigns a port number, so all USB ports on the PC will have the same port number. If you connect different imager engines they are assigned different port numbers. If you want to change the COM port number to any number, you can use the Windows OS device manager.

### 4.2.7 Connection Method

To connect to the host PC:

1. Start the serial communications tool (emulator or UniversalConfig).
2. Connect to the appropriate COM port.

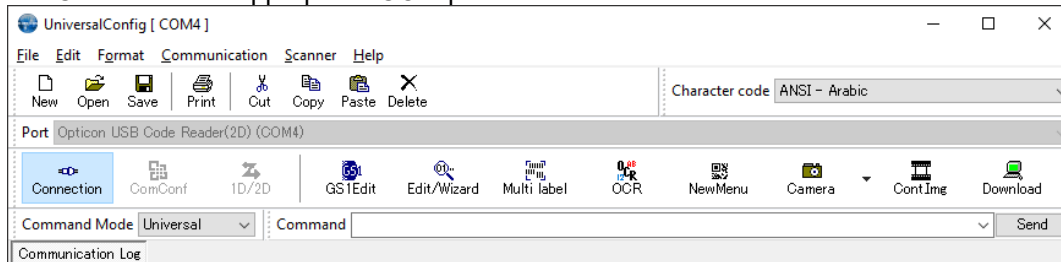

3. To use a command packet, see “[Configuring with a Command Packet](#)”.

### 4.2.8 COM to HID Output (WIME)

WIME (Windows .NET Application) converts data received by the imager engine via the virtual COM port (USB-COM) to HID-like data and transfers the data to the application that has focus.

WIME can resolve the issue of multi-byte characters not being correctly output as USB-HID.

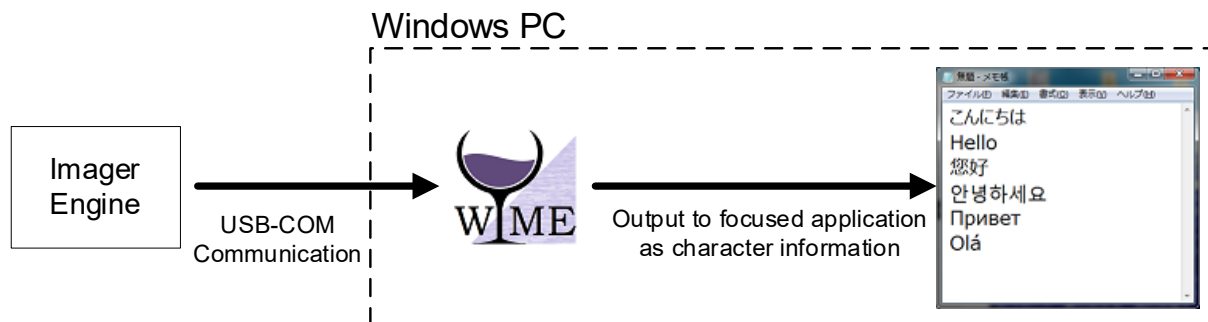

#### 4.2.9 Troubleshooting USB-COM

Use this table to find possible solutions to common USB-COM problems.

Problem	Possible Solution
Not recognized by the PC (Imager engine does not appear in the device manager)	<ul style="list-style-type: none"> <li>• Make sure the USB cable is properly connected.</li> <li>• Make sure the connected USB port is operating properly.</li> <li>• If you are trying to connect to wireless devices, like Bluetooth disconnect and reconnect the device.</li> <li>• Check the USB port power supply capability. When using a laptop or hub, the power supply capacity may not be sufficient.</li> <li>• Disconnect the imager engine from the USB, wait for a few seconds, and reconnect the imager engine.</li> <li>• Connect the imager engine to a different port.</li> </ul>
Error beep sounds and does not output by reading	<ul style="list-style-type: none"> <li>• Try the possible solutions to the previous problem.</li> <li>• Open the COM port with the communication tool.</li> </ul>
Cannot connect (cannot open COM port)	<ul style="list-style-type: none"> <li>• Use the device manager to confirm the COM port number. For help, see "<a href="#">USB-COM Connection Confirmation</a>".</li> <li>• Close the tool and re-open it. Operation and countermeasures vary depending on the tool. Please refer to the tool help or manual.</li> <li>• Reboot the PC.</li> </ul>
Garbled characters	Make sure the barcode you are trying to read matches the character code of the communication tool.
Line-break is doubled	Check the line-break setting of the communication tool.

## 4.3 USB-HID

---

This chapter explains USB-HID interface related settings.

- 4.3.1 [Switching the Interface to USB-HID](#)
- 4.3.2 [USB Interface Signal](#)
- 4.3.3 [USB-HID Basic Information](#)
- 4.3.4 [USB-HID Connection Confirmation](#)
- 4.3.5 [NumLock and CapsLock control](#)
- 4.3.6 [Data Output Speed \(USB-HID\)](#)
- 4.3.7 [USB-HID Inter Character Delay](#)
- 4.3.8 [Keyboard Language](#)
- 4.3.9 [Multi Byte Characters Output](#)
- 4.3.10 [Multi Byte Characters Output setting](#)
- 4.3.11 [Troubles Shooting USB-HID](#)
- 4.3.12 [USB-HID Precautions](#)

### 4.3.1 Switch the Interface to USB-HID

To switch the interface from UART or USB-COM to USB-HID, send a command or read a 2D menu code. When using the USB-HID interface, make sure the 12-pin FFC cable is connected to USB signals.

**Caution: UART is a standard factory default setting. If the host side is USB, communication will fail.**

#### Change Interface to USB-HID

Command	Menu Code	Notes
[X.ZSU[X.ZZ2	 @MENU_OPTO@ZZ@X.Z@SU@X.Z@ZZ@OTPO_UNEM@	Confirm host

### 4.3.2 USB Interface Signal

An IRISO Electronics co. .ltd 9681-12(12-PIN) (bottom contact) equivalent connector is used.

No.	Name	Function	I/O	Conditions	State	Note
1	TRIGn	Trigger	In		L: Start operation H: No action	100kΩ pull up on imager engine
2	AIM/WAKEn	Recovery signal from Low Power state	In		L: Recover from low power state H: No action	100kΩ pull up on imager engine
		Aiming control signal in states other than Low Power	In		L: Aiming LED on H: Aiming LED off	
3	GR_LEDn	Good read LED	Out		L: LED on H: LED off	4.7kΩ pull up on imager engine
	EX_ILLUM	Control of an external light source.	Out	Configured*1	L: External Illumination On H: External Illumination Off	
4	BUZZERn	Buzzer	Out			A transistor or FET should be used to drive a buzzer.
5	POWERDWN	Indicates Low Power state	Out		L: Normal state H: Low Power state	100kΩ pull up on imager engine
6	RTS	Communication control signal to host system	Out		Set to Open	10kΩ pull up on imager engine
7	USB+	Communication control signal from host system	In/Out			
8	TxD	Transmitted data signal	Out		Set to Open	10kΩ pull up on imager engine
9	USB-	Received data signal	In/Out			
10	GND	System ground				
11	Vcc	Power input	In		3.3V or 5.0V	
12	Reserve		In			N.C

\*1 When this signal is set, Good Read LED cannot be used.

\*2 Tone/sound pressure is adjustable by using the Pulse Width Modulation (PWM) signal.

### 4.3.3 USB-HID Basic Information

#### Basic USB-HID Parameters

Parameter	Description	Notes
USB	USB2.0 Full Speed	
Required power supply capacity	500 mA	Differs from actual power consumption.
Vendor ID	065A	
Product ID	A001	
Num/Caps Lock control	Set when using NumLock/CapsLock	Initial value: No control
Data transmit speed	Use when outputting data with high speed.	Initial setting: 4 ms (Setting range 1 ms -16 ms)
Data transmit interval (Inter character delay)	Use when data is missing.	Initial value: no interval
Suspend mode (Remote wakeup)	Use when host system is using suspend.	Initial value: Valid
Keyboard language	Set according to the keyboard language.	Initial value: English (USA)
Character code	Set according to reading symbol encode data.	Initial value: not use character code
Output mode	Set when outputting Chinese-character.	Initial value: output as it is

### 4.3.4 USB-HID Connection Confirmation

The USB-HID interface operates by being connected to the computer.

To confirm the USB-HID connection (Windows 10):

1. Connect the imager engine to the PC.
2. Right-click the Windows icon and select **Device Manager**.
3. Expand **Human Interface Devices**. "USB Input Device" appears in the list.

**Note:** When using a USB-connected device like a mouse or keyboard, multiple devices are displayed.

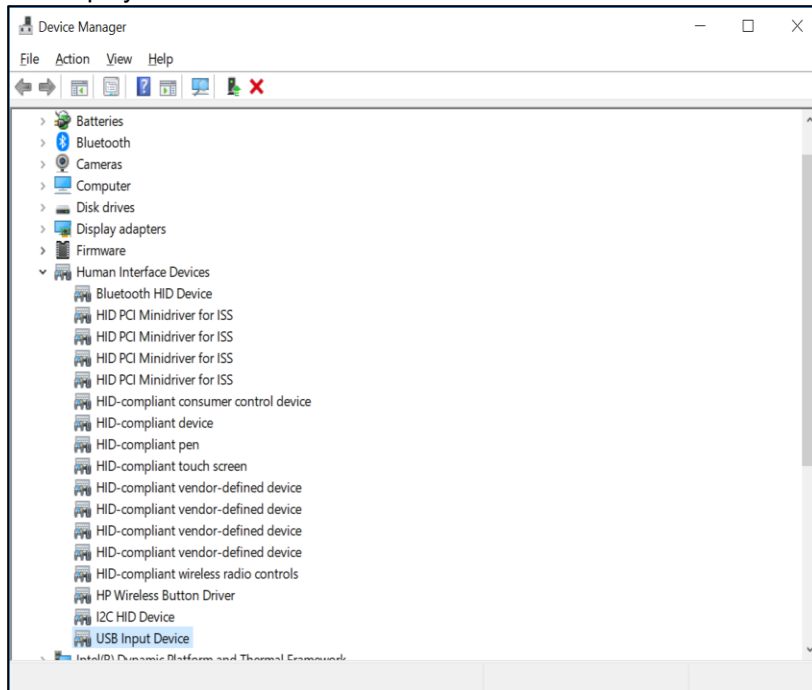

### 4.3.5 NumLock and CapsLock Control

Set NumLock and CapsLock control when sending data.

#### NumLock and CapsLock Control Commands

Parameter	Command	Description	Initial Setting	Notes
NumLock Control	RN	Numeric value does not use numeric keypad	✓	
	RM	Numeric value use numeric keypad		
	/A	Follow NumLock status		*1
CapsLock Control	5Q	No control	✓	
	8A	Invert CapsLock status		*2
	2U	CapsLock automatic control		*3

\*1 Only use numeric keypad when NumLock is ON.

\*2 When starting transmits, send CapsLock and invert status. Use this when CapsLock is always ON. Return to CapsLock status when sending is completed.

\*3 CapsLock status is controlled to appear as the original string. Return to original CapsLock status when transmit is complete.

### 4.3.6 Data Output Speed (USB-HID)

Adjust data output speed in USB-HID. Selecting shorter time will make output faster, but depend on host system, outputting all character may fail.

To enable this setting, reboot is necessary after saving the setting.

#### USB-HID Data Transfer Interval Command

Command			Description	Default(Effective Range)
[E9M	Qa	Qb	Set transfer interval Interval: (10a+b) ms 「Unit」	4 ms 1 ms – 16 ms

Example: Set the transmit interval to 1ms (fastest).

Command: [E9MQ1

Example: Set the transmit interval to 10ms.

Command: [E9MQ1Q0

### 4.3.7 USB-HID Inter Character Delay

The inter character delay introduces a configurable delay after each transmitted character.

This may be used if the host does not support flow control and is not capable of handling the received data at full speed.

#### USB-HID Inter Character Delay Commands

Command	Description	Default
LA	No delay	✓
LB	Delay = 1	
LC	Delay = 2	
LD	Delay = 3	
LE	Delay = 4	
LF	Delay = 5	
LG	Delay = 6	
LH	Delay = 7	
LI	Delay = 8	
LJ	Delay = 9	
LK	Delay = 10	

### 4.3.8 Keyboard Language

Set the keyboard language used on the host PC connected to the imager engine to be connect. Keyboard arrangement differs depending on the country or language. If the setting is incorrect, output will be incorrect.

#### Keyboard Language Commands

Command	Description	Code Page
KE	USA	✓
KV	UK	
KG	German	
KI	French	
OW	Italian	
KJ	Spanish	
PH	Portuguese	
PL	Swiss French	
PK	Swiss German	
PI	Dutch	
PJ	Belgian	
PD	Swedish	
PG	Finnish	
KK	Danish	
PE	Norwegian	
WF	Czech	
[BAY	Hungarian	
[BPJ	Turkish	
[EF4	Russian English	
[EF5	Russian Cyrillic	
[BAZ	Brazilian	
[E76	Chinese	
[E77	Korean	
[E78	Taiwanese	
PM	Japan	
[EGK	Croatia	
[BPP	Poland (214)	
[BP2	Poland (programmer)	
[EGS	Greece	
[EGT	Greece (English)	
[EGU	Greece (Latin)	
[EGV	Greece (220)	
[EGW	Greece (319)	

### Keyboard Language Commands (continued)

Command	Description	Code Page
[EGX	Greece (220 Latin)	
[EGY	Greece (319 Latin)	
[EGZ	Greece (polytonic)	
[EHD	Indonesia	
[EHE	Latin America	
[EHF	Vietnam	
[EHG	America (International)	
[EHH	Canada (France)	
[EHI	Canada (France) Legacy	
[EHJ	Canadian Multilingual Standard	

### 4.3.9 Multi-Byte Character Output

If a barcode contains multi-byte characters or country-specific characters, you need to configure the imager engine for multi-byte character output.

#### Configure Multi-Byte Character Output

To configure the imager engine for multi-byte character output:

1. Set the keyboard language to match the connected PC. For example, if you are connecting to a PC that uses US OS, set the keyboard language to “USA.” For help, see [“Keyboard Language”](#).
2. Use UniversalConfig to configure the multi-byte character output setting. For help, see [“Multi-Byte Character Output Setting”](#).

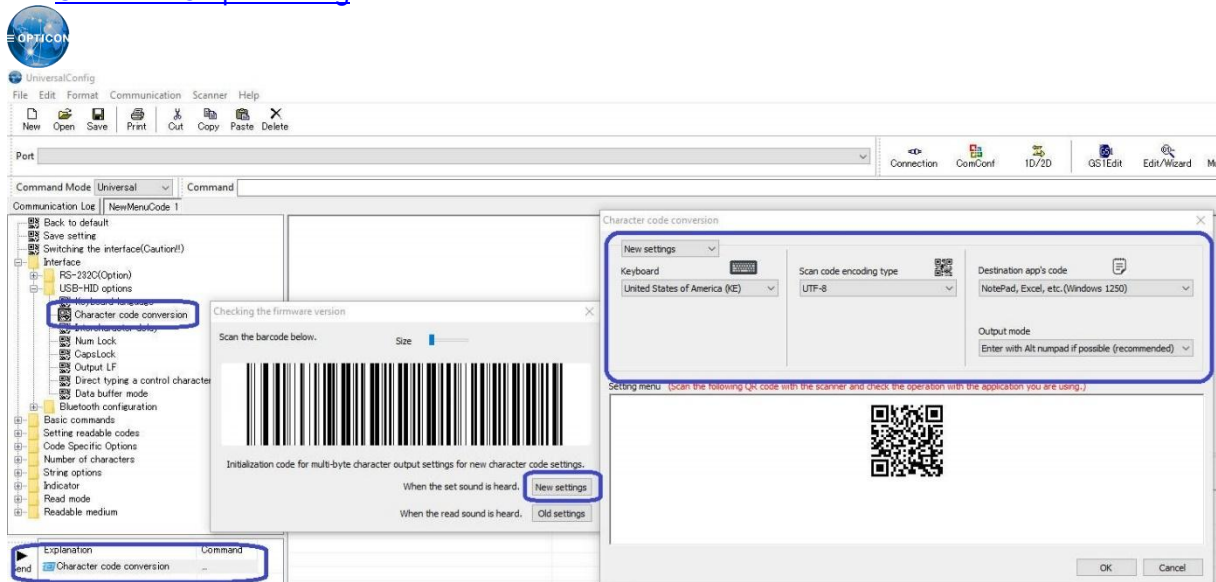

3. Configure additional settings as necessary.

### 4.3.10 Multi-Byte Character Output Setting

In multi-byte character output, two types of character code type (code encoded type and application code type) and output mode are set.

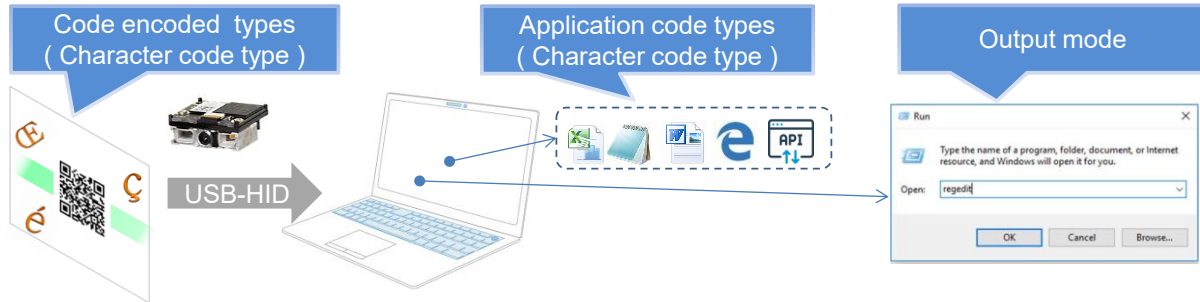

Codes created in UTF-8 can be output to Notepad (Windows 1252).

Character code types:

- Code encoded type: The encoding type of the code that contains multi-byte characters depends on the purpose and the barcode label creation tool. For example, in the US, select “Windows 1252” or “UTF-8”.
- Application code type: The application code type depends on the Windows application. For US English, select “Windows 1252” or “UFT-16”.

#### Application Code Types

Application	Character Code Type*
Microsoft Excel	Default character code type (Windows 1252)
Microsoft Notepad	Default character code type (Windows 1252)
Microsoft Word	UTF-16
Web application	See the next procedure, <a href="#">“To confirm application code type.”</a>
Own application	See the next procedure, <a href="#">“To confirm application code type.”</a>
Other	See the next procedure, <a href="#">“To confirm application code type.”</a>

\* Character code type descriptions may change based on Windows updates.

To confirm application code type:

1. Press and hold the **Alt** key.
2. On the numeric keypad, enter 0128.  
Or, enter 8364
3. Release the **Alt** key.

If you entered 0128 and € is displayed, Windows1252 is supported.

If you entered 8364 and € is displayed, UTF-16 is supported.



**Character Code Setting Commands**

Command					Description
[CCL	Qa	Qb	Qc	Qd	
	a	b			Set code encoding type: QaQb
			c	d	Set application code type: QcQd

Character Code Type	Characters and Regions Mainly Used	Parameter
Windows 1250	Central Europe	Q0Q0
Windows 1251	Cyrillic	Q0Q1
Windows 1252	Western Europe, USA	Q0Q2
Windows 1253	Greece	Q0Q3
Windows 1254	Turkey	Q0Q4
Windows 1255	Hebrew	Q0Q5
Windows 1256	Arabia	Q0Q6
Windows 1257	Baltic	Q0Q7
Windows 1258	Vietnam	Q0Q8
Windows 874	Thai	Q0Q9
Windows 932 (Shift-JIS)	Japan	Q1Q0
Windows 936 (GB2312)	China	Q1Q1
Windows 949 (UHC)	Korea	Q1Q2
Windows 950 (Big-5)	Taiwan	Q1Q3
UTF-8	Universal	Q5Q0
UTF-16		Q5Q1
No character code	Default setting	Q9Q9

### Output Mode

Set the output mode when outputting multi-byte characters. If you set “Keyboard language” and “Character code type”, select “Alt decimal number mode (characters other than keyboard layout)”.

### Output Mode Command

Command	Description
[C20 Qx	Select output mode: Qx

### Output Modes

Output Mode	Output Method	Parameter
Output all values as is	Default setting	Q0
Alt decimal number mode (characters other than keyboard layout)	Press and hold the <b>Alt</b> key, and then press keys on the numeric keypad to output the specific character. Characters in the keyboard layout are output by pressing the key.	Q4
Alt decimal number mode (always)	Press and hold the <b>Alt</b> key, and then press the keys on the numeric keypad to output the specific character. The characters in the keyboard layout are output in the same way.	Q5
Alt + hexadecimal number mode (characters other than keyboard layout)	Press and hold the <b>Alt</b> key, and then press the <b>Full</b> key to output the specific character. Characters in the keyboard layout are output by pressing the key. (registry setting is required)	Q6
Alt + hexadecimal number mode (always)	Press and hold the <b>Alt</b> key, and then press the <b>Full</b> key to output the specific character. Characters in the keyboard layout are output in the same way. (registry setting is required)	Q7

In Windows OS (NT series), characters can be output by entering numerical values while pressing the **Alt** key:

- Alt decimal number mode: Below keyboard keys in the green box. (Left Alt key and numeric keypad 0 to 9 keys)
- Alt hexadecimal number mode: Below keyboard keys in the red box. (Left Alt key, numeric keypad + key, 0 to 9 keys and A to F keys)

Example: Output “€”

Alt decimal number mode:

Press and hold the **Alt** key, and then press “0128” (decimal number of Windows1252 0x80)

Alt hexadecimal number mode:

Press and hold the **Alt** key, and then press “+ 2 0 A C” (UTF-16[Unicode] U+20AC)

### Output Mode Characteristics

Characteristics	Alt Decimal Number Mode	Alt + Hexadecimal Number Mode
Code type of output application	Set according to application	Optional *(Set to UTF-16)
Registry value setting	Not required	Required

\*Normal output for all applications is not guaranteed.

Alt decimal number mode must be set based on the application to output. But, the PC registry setting is not required. Conversely, setting Alt + hexadecimal number mode based on the application to output is optional, but the PC registry setting is required.

Many Japanese multi-byte characters (including Chinese characters) can be supported by the output of Alt decimal number mode. Use Alt + hexadecimal number mode for special cases, like “Some Chinese character output fail” or “Output result differs in each application which is scheduling to use”.

For registry setting, see the next procedure, .refer to “Alt + hexadecimal number mode registry setting method”.

### Alt + Hexadecimal Number Mode Registry

Start the registry editor and create or change the indicated key. After execution, reboot the PC.

Characteristic	Alt Decimal Number Mode	Alt + Hexadecimal Number Mode
Code type of output application	Set according to application	Optional *(Set to UTF-16)
Registry value setting	Not required	Required

To configure the Alt + hexadecimal number mode registry:

1. From the Run command line, execute “regedit”.

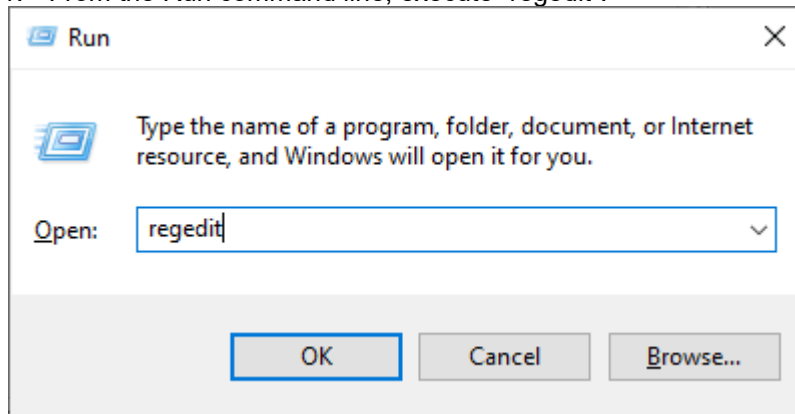

2. Go to **HKEY\_CURRENT\_USER > Control Panel > Input Method**.

3. Right-click **Input Method**, select **New**, and click **String Value**.

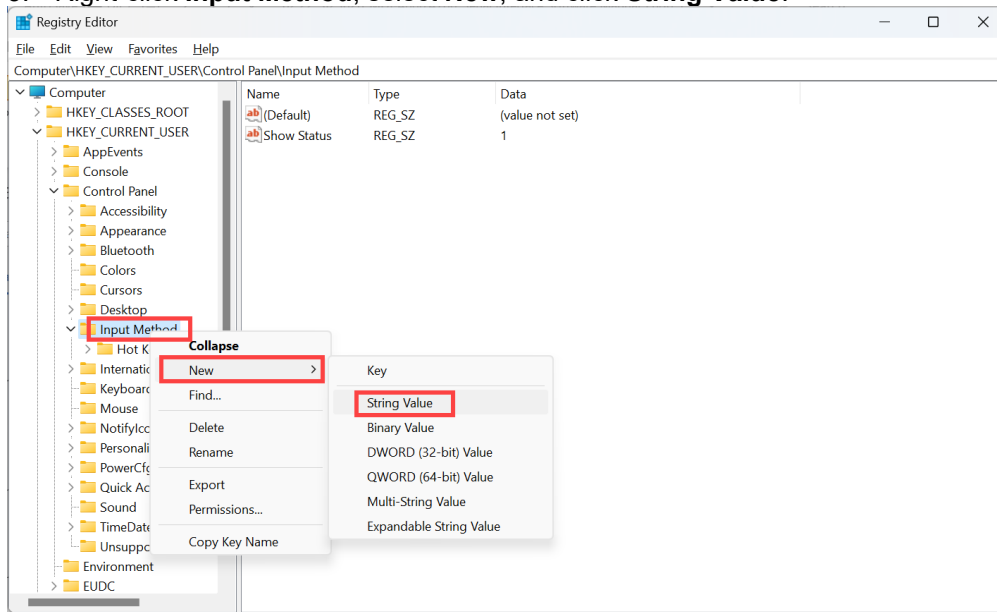

4. For **New Value #1** enter “EnableHexNumpad”. key and input “1” as for the value.

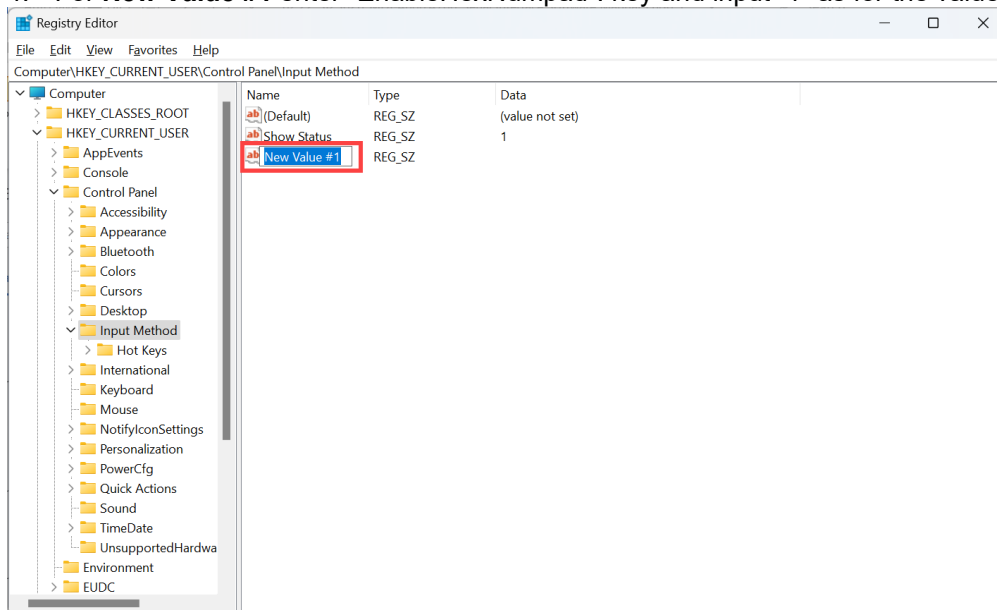

5. Right-click **EnableHexNumpad** and click **Modify**.

6. For **Value data**, enter “1” and click **OK**.

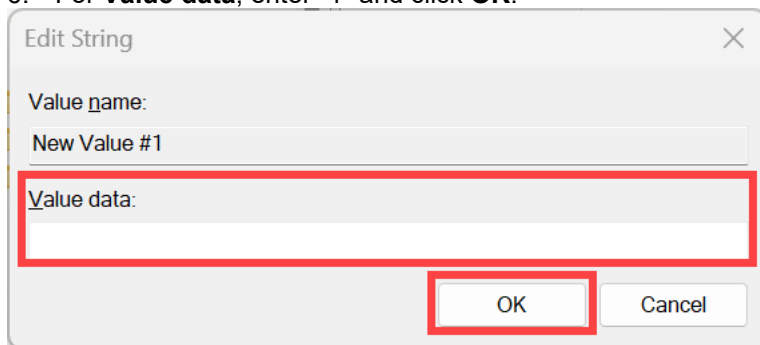

### 4.3.11 Troubleshooting USB-HID

Use this table to find possible solutions to common USB-HID problems.

Problem	Possible Solution
Output is not correct	<ul style="list-style-type: none"> <li>Set the keyboard language and output destination application setting correctly.</li> </ul>
Garbled characters	<ul style="list-style-type: none"> <li>If the host side processing speed is not sufficient, configure an inter character delay.</li> <li>If a control string is included, make sure that Ctrl + “any alphabet key” does not overlap with the shortcut key on the host side.</li> </ul>
Line-break is doubled	<ul style="list-style-type: none"> <li>Set the suffix additional setting based on the host side application’s line-break.</li> </ul>
Cannot output images	<ul style="list-style-type: none"> <li>Images cannot be output.</li> </ul>
The imager engine does not appear in Device Manager.  Restart unexpectedly.  Error beep sounds and does not output by reading	<ul style="list-style-type: none"> <li>Make sure the USB cable is properly connected.</li> <li>Make sure the connected USB port is operating properly.</li> <li>Verify the USB port power supply capability. If you are using a laptop or hub, make sure power supply capacity is sufficient.</li> <li>Disconnect the imager engine from the USB port. Connect the imager engine again.</li> <li>Connect the imager engine to a different port.</li> </ul>

### 4.3.12 USB-HID Precautions

When emulating keyboard operation the output destination environment affects the result, especially when using control character output (Ctrl + “any alphabet key”) and multi-byte output setting. Make sure to verify that the code used is appropriate for the output destination environment.

## 4.4 Common Settings

---

This section describes settings that are common to all interfaces.

### 4.4.1 Data Buffer Mode

This option allows you to specify whether to read an object during data output. When buffer mode is enabled, the imager engine can perform other operations, such as barcode scanning, while outputting decoded data. But, reading performance may degrade during the data output. When buffer mode is disabled, the imager engine stops other operations until decoded data output is complete.

#### Data Buffer Mode Commands

Command	Description	Default
[D80	Data buffer disable	
[D81	Data buffer enable *	✓

## **5 Power Management and Timing**

This chapter describes the power management and various timings of the imager engine. The configurations available are:

### **5.1 [Power Mode Transition](#)**

#### **5.2 [Current Consumption](#)**

#### **5.3 [Low Power](#)**

#### **5.4 [Recovery from Low Power Mode](#)**

#### **5.5 [Power ON /OFF Timing](#)**

#### **5.6 [Read Timing](#)**

## 5.1 Power Mode Transition

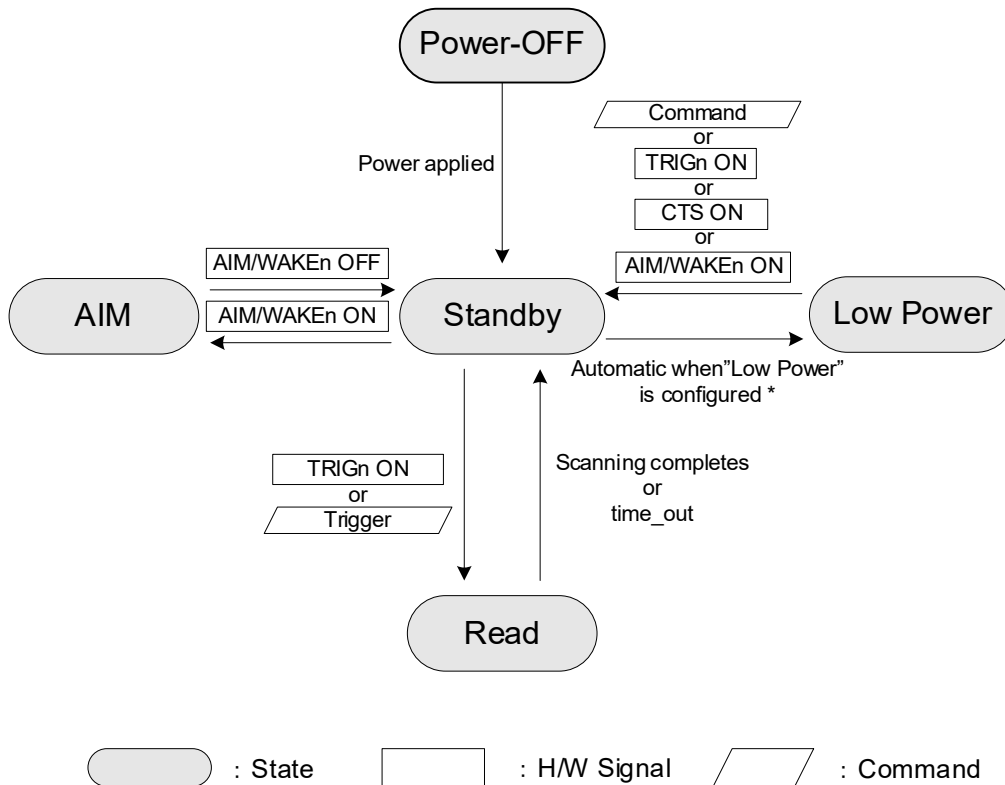

\* When Low Power is enabled, the MDI-4600 and MDI-4700 automatically enter Low Power mode after being in Standby for the specified time.

### Power Mode Status Descriptions

Status	Description
Read	White LED illumination and laser aiming light. Reading is processed.
Standby	Ready to read. The state that can read immediately.
Low Power	Low current consumption status. The amount of time to move from Standby is configurable.
AIM	When the AIM signal is ON, a single line green aiming light is on.

## 5.2 Current Consumption

Each electrical specifications of the imager engine are as follows.

### 5.2.1 Absolute Maximum Ratings

**Note:** Stresses beyond those listed under Absolute Maximum Ratings may cause permanent damage to the device. These are stress ratings only and functional operation of the device at these or any other conditions beyond those indicated under Recommended Operating Conditions is not implied. Exposure to absolute maximum rated conditions for extended periods of time may affect device reliability.

Voltage	Symbol	Rated Value	Unit
Power Supply Voltage ( $V_{CC}$ to GND)	$V_{CC}$	-0.3 to 6.0	V
Input Voltage	$V_i$	-0.3 to $V_{CC} + 0.3$	V

### 5.2.2 Recommended Operating Conditions

Voltage or Current	Symbol	Conditions	Min.	Typ.	Max.	Unit	
Supply Voltage	$V_{CC}$		3.0	3.3/5.0	5.5	V	
Input Voltage	Low	$V_{IL}$	$V_{CC}=3.0$ to $3.6V$	0	-	0.8	V
			$V_{CC}=4.5$ to $5.5V$	0	-	$0.3 \cdot V_{CC}$	
	High	$V_{IH}$	$V_{CC}=3.0$ to $3.6V$	2.0	-	$V_{CC}$	V
			$V_{CC}=4.5$ to $5.5V$	$0.7 \cdot V_{CC}$	-	$V_{CC}$	
Output Voltage	Low	$V_{OL}$	$I_{OL} = 100\mu A$	-	0.1	V	
	High	$V_{OH}$	$I_{OH} = -100\mu A$	$V_{CC}-0.1$	-	$V_{CC}$	V
Output current	Low	$I_{OL}$			-25	mA	
	High	$I_{OH}$			25	mA	

### 5.2.3 Peak Current Consumption

( IF:UART/USB,  $V_{CC} = 3.3V$   $T_A = 25^\circ C$ )

Current	State	Symbol	Conditions	Min.	Typ.	Max.	Unit
Peak Rush Current *	Boot	$I_{PK}$	-	-	1000	-	mA

\* Measured at the MDI-4600 and MDI-4700 connector.

**Note:** In-rush current waveform is equivalent to the MDI-40x0/MDI-41x0.

## 5.2.4 Current Consumption of the MDI-4600 and MDI-4700

### UART

 [ V<sub>CC</sub> = 3.3V]

 ( IF:UART, T<sub>A</sub> = 25°C)

Current	State	Recovery Time *	Symbol	Conditions	Min.	Typ.	Max.	Unit
Operating Current	Read	-	I <sub>OP</sub>	-	-	240	300	mA
Standby Current	Standby	0 ms	I <sub>STB</sub>	-	-	29	-	mA
Low Power Current	Low Power	37 ms	I <sub>LOW</sub>	Configured**	-	0.8	-	mA

 [ V<sub>CC</sub> = 5.0V]

 ( IF:UART, T<sub>A</sub> = 25 °C)

Current	State	Recovery Time *	Symbol	Conditions	Min.	Typ.	Max.	Unit
Operating Current	Read	-	I <sub>OP</sub>	-	-	150	210	mA
Standby Current	Standby	0 ms	I <sub>STB</sub>	-	-	19	-	mA
Low Power Current	Low Power	37 ms	I <sub>LOW</sub>	Configured**	-	0.6	-	mA

\* Recovery time is time until ready to scan.

\*\*Refer to the “Serial Interface Specifications” for details.

### USB

 [ V<sub>CC</sub> = 3.3V]

 ( IF:USB, T<sub>A</sub> = 25°C)

Current	State	Recovery Time *	Symbol	Conditions	Min.	Typ.	Max.	Unit
Operating Current	Read	-	I <sub>OP</sub>	-	-	290	380	mA
Standby Current	Standby	0 ms	I <sub>STB</sub>	**	-	65	-	mA
Low Power Current	Low Power	37 ms	I <sub>LOW</sub>	Configured**	-	1.0	-	mA

 [ V<sub>CC</sub> = 5.0V]

 ( IF:USB, T<sub>A</sub> = 25°C)

Current	State	Recovery Time *	Symbol	Conditions	Min.	Typ.	Max.	Unit
Operating Current	Read	-	I <sub>OP</sub>	-	-	175	250	mA
Low Power Current	Standby	0 ms	I <sub>STB</sub>	**	-	42	-	mA
Low Power Current	Low Power	37 ms	I <sub>LOW</sub>	Configured**	-	0.8	-	mA

\* Recovery time is time until ready to scan.

\*\* Current value when USB is “Selective Suspend” mode. When using as USB-COM (USB as virtual COM), use USB driver “Opticon USB Code Reader driver” version 3.x.x.x. Refer to the “Serial Interface Specifications” for details.

## 5.3 Low Power

Low power mode helps to further reduce power consumption when in the Standby mode. Also, the contents set in the imager engine will not be disposed when shifting to the low power mode.

### 5.3.1 Enable/Disable Low Power

The following commands are provided for the low power standby setting.

#### Low Power Standby Commands

Command	Description	Default
[XSC	Disable low power mode	✓
[EB8	Enable low power mode	

\* When low power mode is enabled, the initial value of the transition time is set to 5 seconds.

### 5.3.2 Transition Time

The following commands are provided for setting the transition time  $t_1$  to low power. The transition time  $t_1$  means that the imager engine is in “Standby mode”. After the transition time  $t_1$ , the low power becomes effective and the POWERDWN signal becomes high.

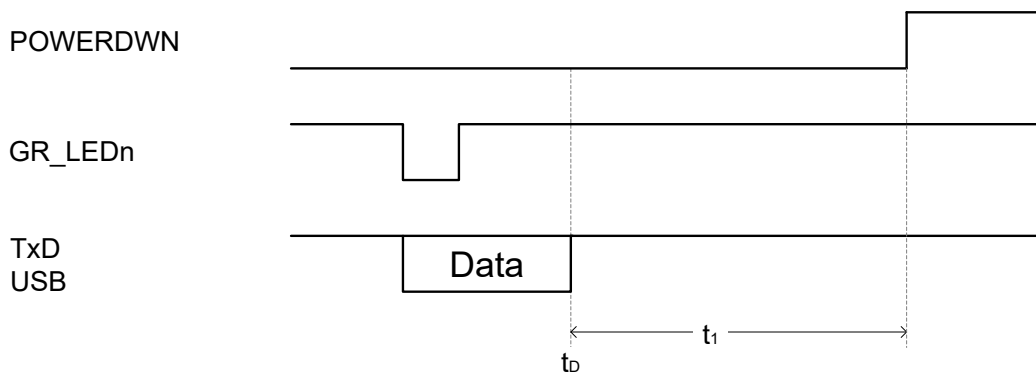

#### Low Power Transition Time Commands

Command	Description	Default
[EBA Qa Qb Qc Qd	Set low power transition time with numerical values (1000a+100b+10c+d [s])	5 s (0 - 9999)

\* When low power transition time is set to 0, the time is set to 150 ms.

Example: command input

Enable “low power mode” and set the transition time to low power to 3 seconds

<ESC>[EB8[EBAQ0Q0Q0Q3<CR>

**Note:** You should set low power transition time as a factory default setting. For help, see [“Custom Command Line Settings \(Change the Factory Default Settings\)”](#).

### 5.3.3 USB Low Power Mode Transition Condition

For USB, the imager engine transitions to low power mode when these conditions are met:

- The imager engine's low power mode is enabled.
- The imager engine passed the specified time (transition time) in standby state.
- The USB bus shifted to SUSPEND mode.

**Note:** The USB bus can be placed in SUSPEND mode when effective USB communication, such as read data or command data, is not performed for a certain period of time. The USB host device controls the management of this mode. Following are the setting method for USB-COM and USB-HID communication Selective suspend.

With USB-COM (USB virtual COM), you can shift USB bus to SUSPEND mode when valid communication is not available by using Opticon USB Code Reader drive version 3.0.0.0 or later and enabling USB Selective suspend. For help, see the Opticon USB Code Reader drive installation manual.

With USB-HID (key code input), when connecting a imager engine and PC that has Windows OS installed, the Windows inbox driver creates the HID connection. By controlling the registry that controls the inbox driver, you can enable USB Selective suspend. For more information about Microsoft MSDN HID USB peripherals, go to [https://msdn.microsoft.com/library/dn672268\(v=vs.85\).aspx](https://msdn.microsoft.com/library/dn672268(v=vs.85).aspx).

### 5.3.4 USB Low Power Mode Communication Sequence

The imager engine detects USB bus shifting to SUSPEND mode and transitions to low power mode. This diagram illustrates the imager engine and USB host device communication sequence.

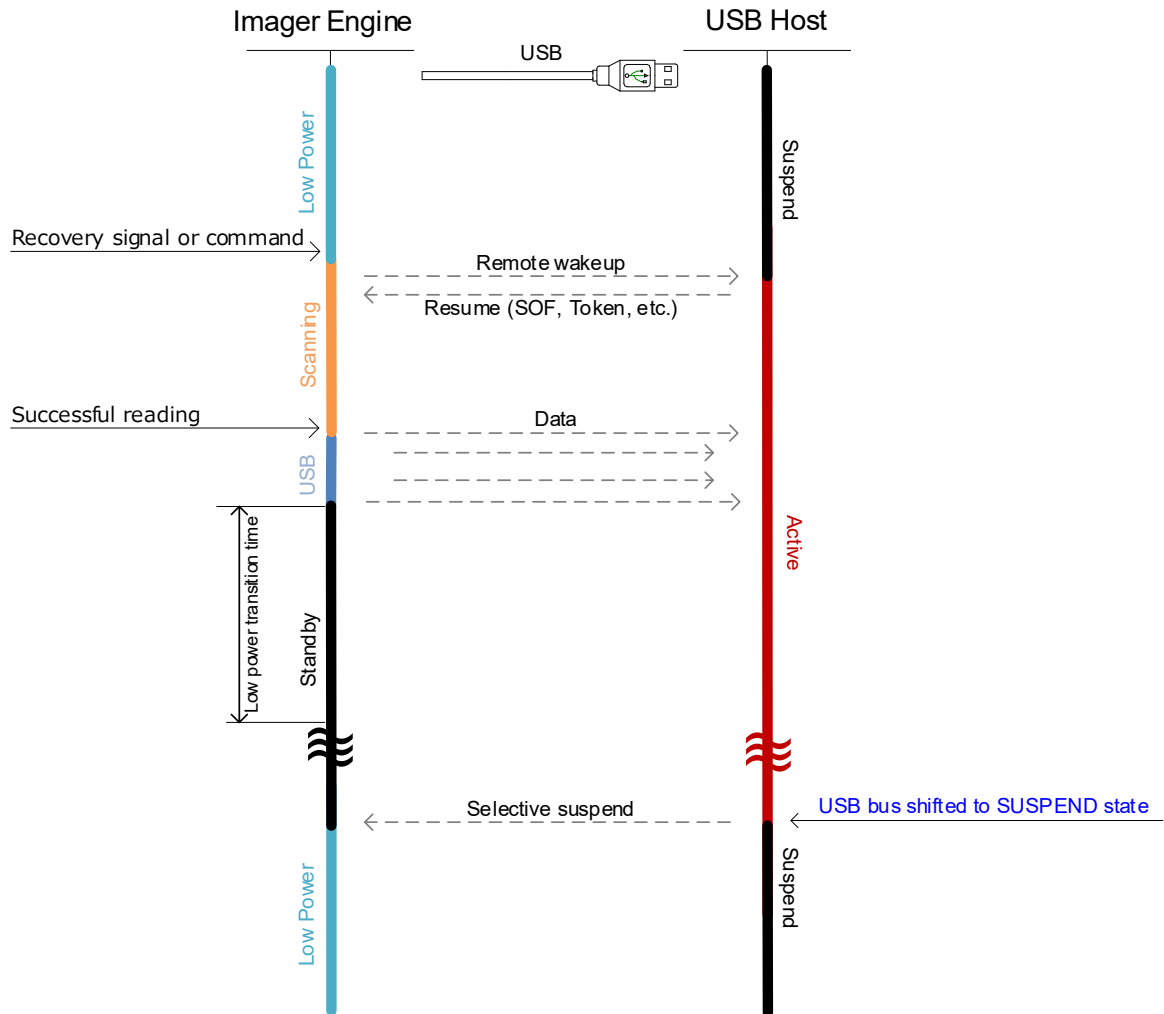

## 5.4 Recovery from Low Power Mode

To recover from low power mode, conditions such as the signal to use and timing must be met.

### 5.4.1 Recovery from Low Power Mode by Signal (UART)

To recover from low power mode, use these signals: TRIGN, CTS, and AIM/WAKEn. If additional setting commands are required, they will be acceptable from the time when the RTS or POWERDOWN signal become low.

Example: Recover using TRIGN signal

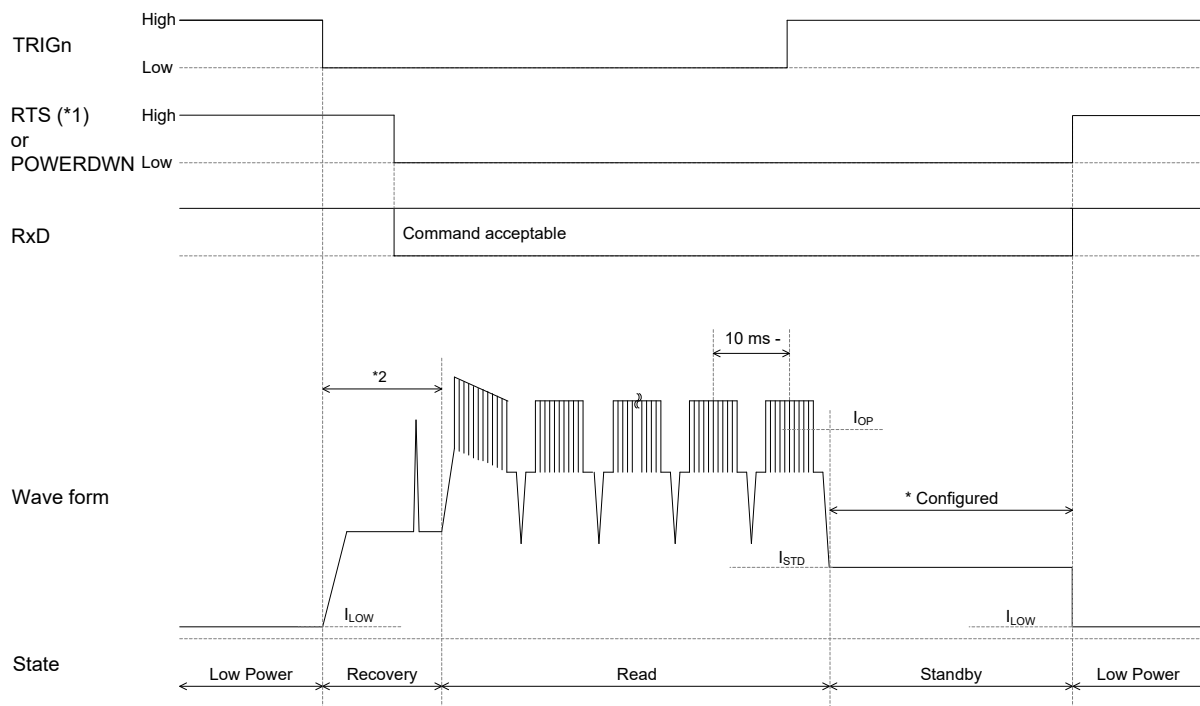

\* For more information about low power mode, see ["Low Power"](#).

\*1 When communication control is set to "MODEM", low power recovery mode cannot be used because the RTS signal becomes "High".

\*2 The typical recovery time for the MDI-4600 and MDI-4700 is 37 ms.

### 5.4.2 Recovery from Low Power Mode by Command (UART)

To recover from the low power mode, you need to send a command.

To recover from low power mode:

1. Sending null or dummy data. For these high baud rates, you need to send null or dummy data multiple times:
  - 230400 bps: 2 times
  - 460800 bps: 3 times
  - 921600 bps: 5 times
2. When the RTS or POWERDWN signal becomes low, send the trigger command "Z".
 

**Note:** If there is no RTS or POWERDWN signal, send the command 20 ms after the recovery starts.

#### Example: Recover from Low Power Mode Using Commands

If additional setting commands are required, confirm the RTS or POWERDWN signal and then send the commands.

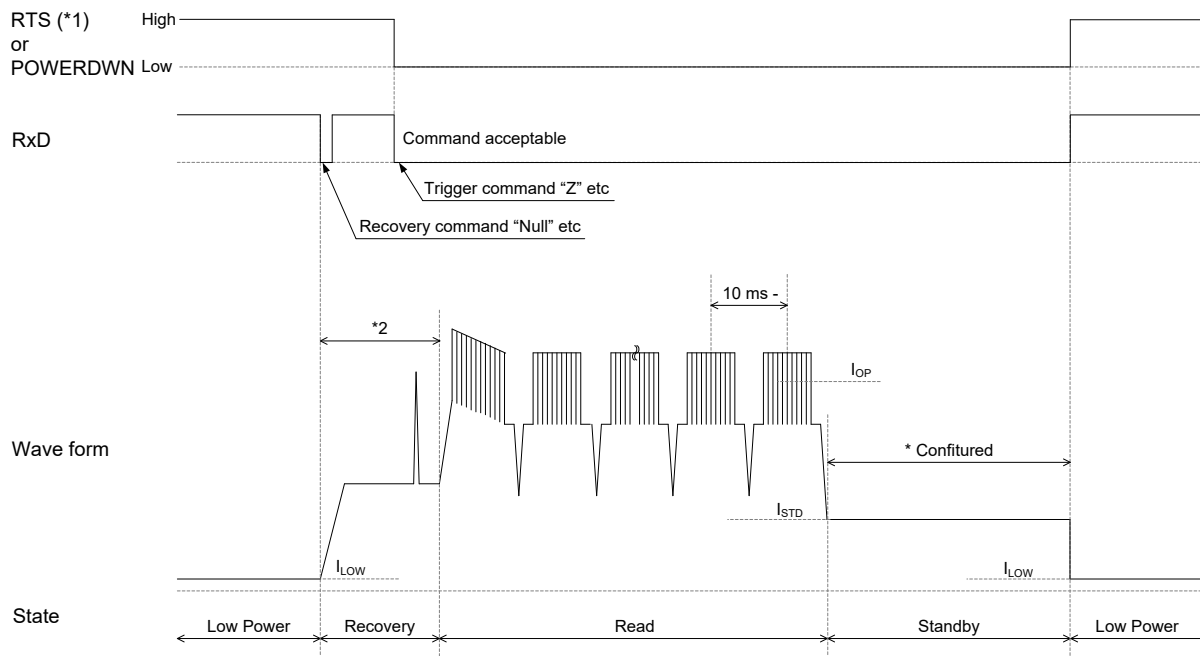

\* For more information about low power mode, see "[Low Power](#)".

\*1 When communication control is set to "MODEM", low power recovery mode cannot be used because the RTS signal becomes "High".

\*2 The typical recovery time for the MDI-4600 and MDI-4700 is 37 ms.

### 5.4.3 Recovery from Low Power Mode (USB)

Recover from low power mode using the TRIGn and AIM/WAKEn signals and a command. Recovery starts with the signal and becomes readable in about 37 ms.

USB always accept the command. USB shifts to Active when the command is sent.

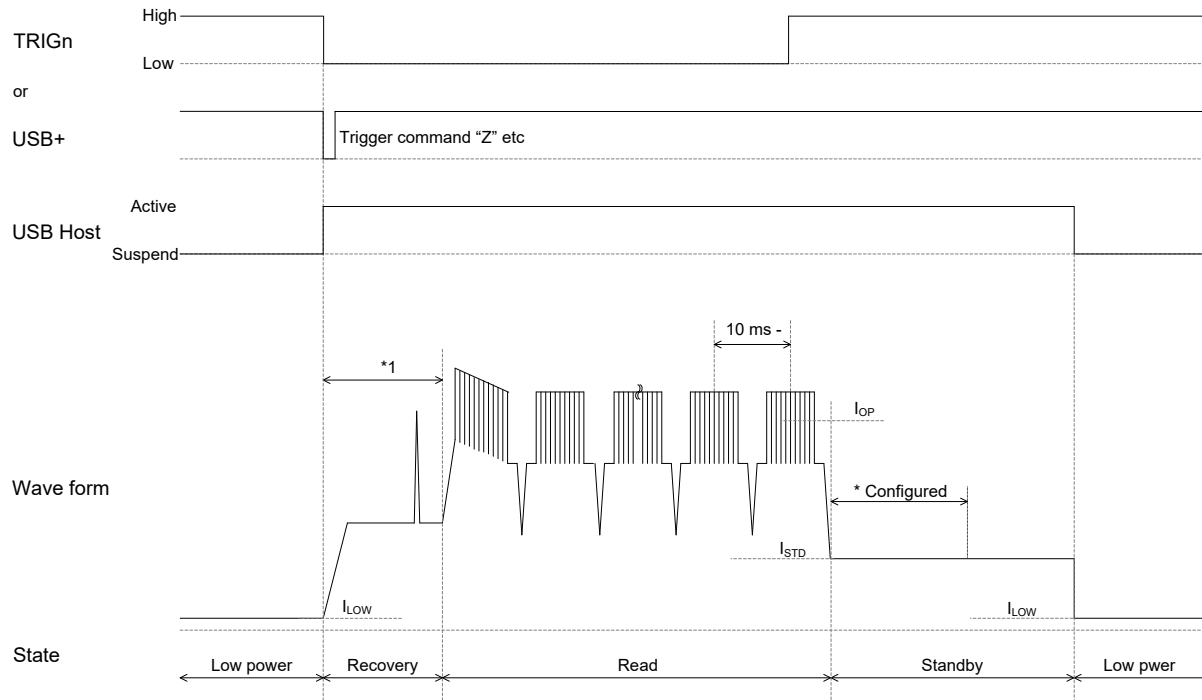

\* For more information about low power mode, see "[Low Power](#)".

\*1 The typical recovery time for the MDI-4600 and MDI-4700 is 37 ms.

## 5.5 Power ON/OFF Timing

### 5.5.1 Power-On Timing

Power-On Timing is the time from when the imager engine is powered on until it is able to read barcodes.

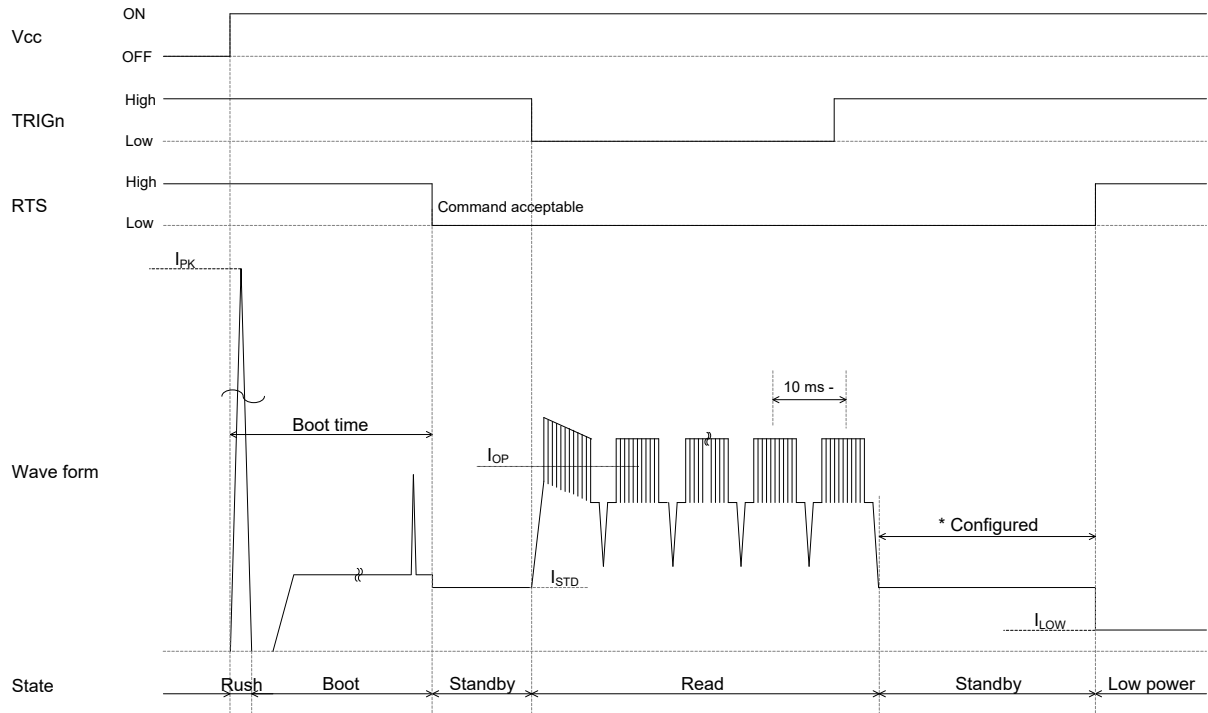

\*1 When communication control is set to "MODEM", Power-On Timing cannot be used because the RTS signal becomes "High".

#### Boot Time

(IF:UART/USB VCC = 3.3V/5.0V TA = 25°C)

Min.	Typ.	Max.	Unit
-	360	1000	ms

## 5.5.2 Power-Off Timing

When the power is turned off while an input signal to the imager engine is high, leakage current is drawn from that signal. So, all input signals to the imager engine should be set to “High impedance” or “Low”.

**Note:** If the time from when the imager engine powers off to when it turns on is 10 ms or more, Vcc 1V or lower is required.

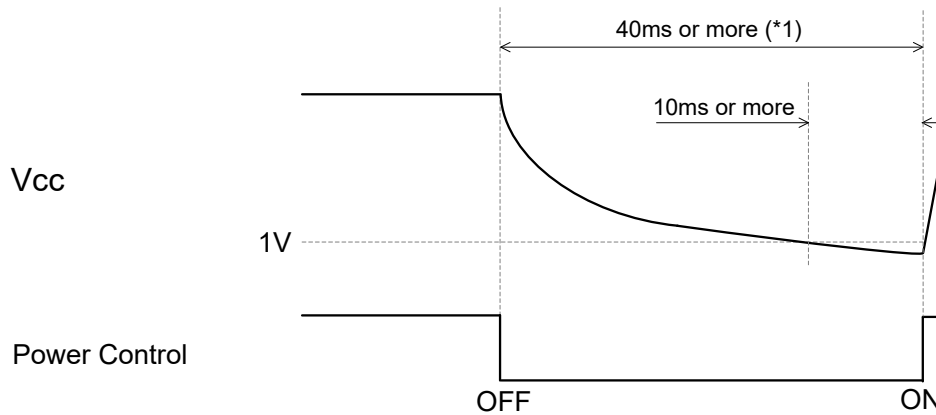

\*1 For MEK-3100 circuit configuration, 40 ms or more is required.

When saving Power-Off Timing settings, note that the settings are stored in the imager engine when:

- the Z2 command is sent to save the parameters.
  - Note:** If “ACK/NAK for serial command” is enabled, the imager engine will send an ACK after configuration data is written, which allows the correct timing to be set.
- after 1D or 2D menu codes are processed.

Writing the settings into the flash ROM can take up to 10 seconds. Make sure the power is not turned off during this period, or the settings may be corrupted.

## 5.6 Read Timing

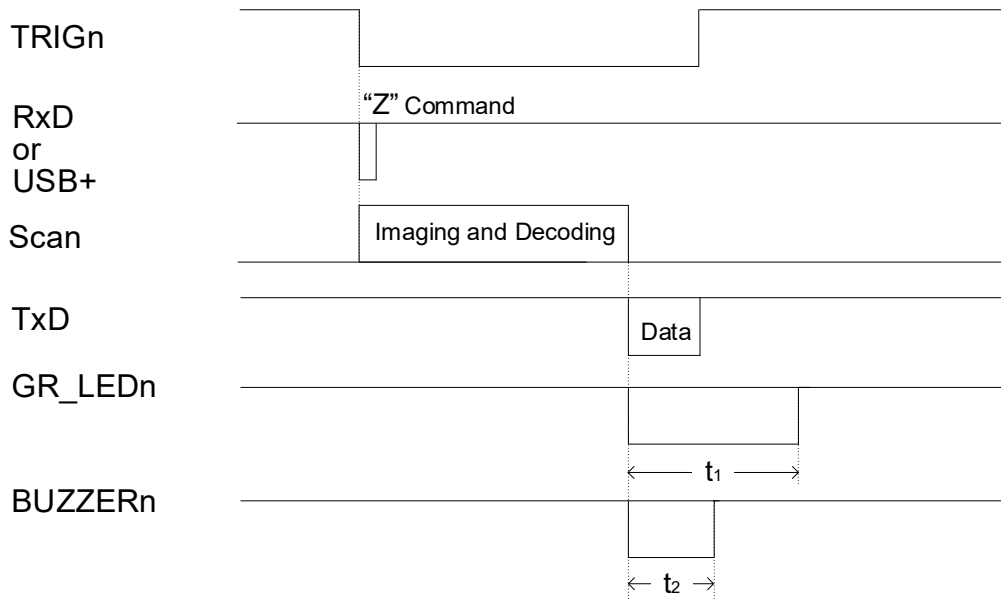

### Read Timing Signal Periods

Symbol	Description	Min	Typ	Max	Unit
$t_1$	GR_LEDn signal period		200 <sup>*1</sup>	-	ms
$t_2$	BUZZERn signal period	-	50 <sup>*2</sup>	-	ms

\*1 You can set the GR\_LEDn signal period. For help, see [“Good Read LED \(GR\\_LEDn Signal\)”](#).

\*2 You can set the BUZZERn signal period. For help, see [“Buzzer \(BUZZERn Signal\)”](#).

### 5.6.1 Read Effective Time

Read effective time sets the reading time of one read operation. After the trigger signal turns on or when the readout command “Z” is sent, the readout operation starts. If no data is output within the specified time, the readout operation stops.

#### Read Effective Time Commands

Command	Description	Default
Y0	Trigger signal synchronization or “Z” “Y” command control	✓
Y1	1 second	
Y2	2 seconds	
Y3	3 seconds	
Y4	4 seconds	
Y5	5 seconds	
Y6	6 seconds	
Y7	7 seconds	
Y8	8 seconds	
Y9	9 seconds	
YM	Read time infinite	
YL	Read time 10 times	

\* When auto trigger is set with “Y0”, read effective time is automatically set by image processing.

Read effective time can also be set with a specific time by entering the command followed by a 4-digit numeric command. The read effective time can be set in increments of 10 ms.

#### Read Effective Time Numeric Setting Commands

Command					Description	Default(Effective Range)
[EF7	Qa	Qb	Qc	Qd	Set read effective time (1000a+100b+10c+d) [x10 ms]	Trigger synchronize

Example: Setting Read Effective Time

Read effective time 500 ms

```
<Esc>[DF7Q0Q0Q5Q0<CR>
0050 x10 = 500 ms
```

\* The setting is in increments of 10 ms.

## 5.6.2 Trigger Signal Control

By default, the trigger synchronization (Y0) TRIGn signal determines the reading time. When the TRIGn signal is active, the imager engine will read.

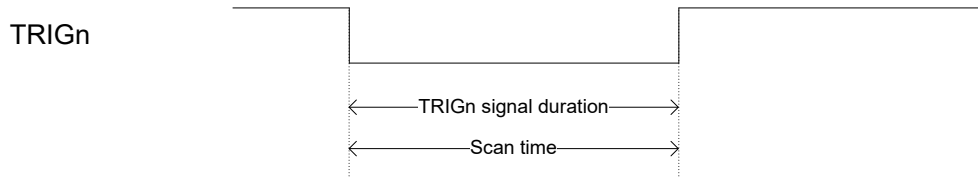

You can set start timing when effective read time is set. For more information, see [“Read Effective Time”](#).

### Effective Read Time Start Timing Command

Command	Description	Default
+O	Counting starts from TRIGn signal end	✓
+P	Counting starts from TRIGn signal start	

The next diagram illustrates counting starting from the TRIGn signal end.

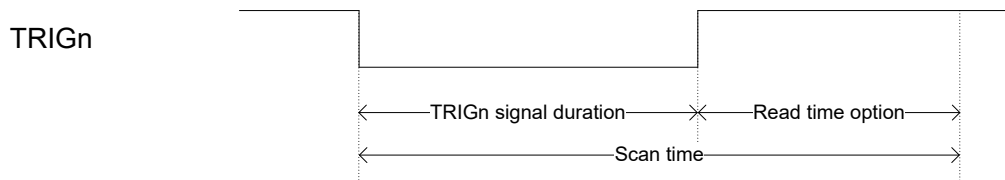

The next diagram illustrates counting starting from the TRIGn signal start.

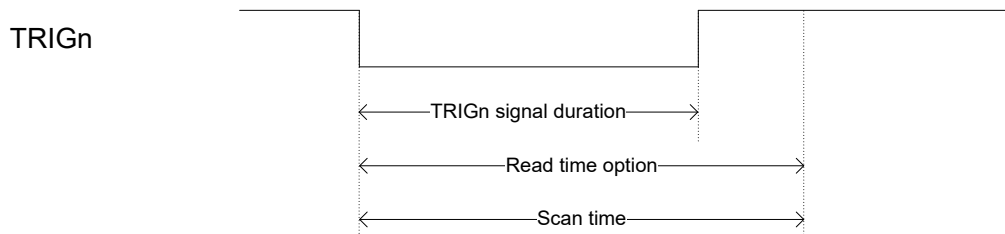

### 5.6.3 Command Trigger Control

Command Trigger Control starts reading with the trigger “Z” command and stops reading by sending “Y” command.

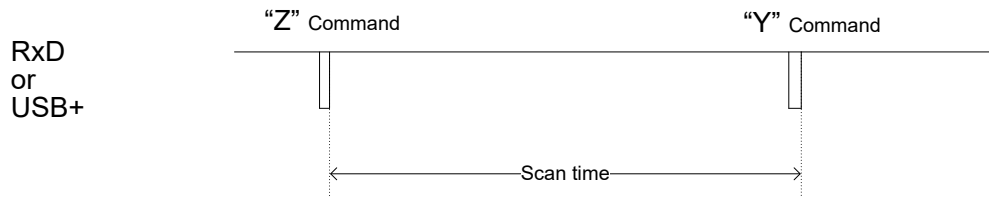

When Read Effective Time is set, the imager engine stops reading when the set time elapses and when the “Y” command is sent.

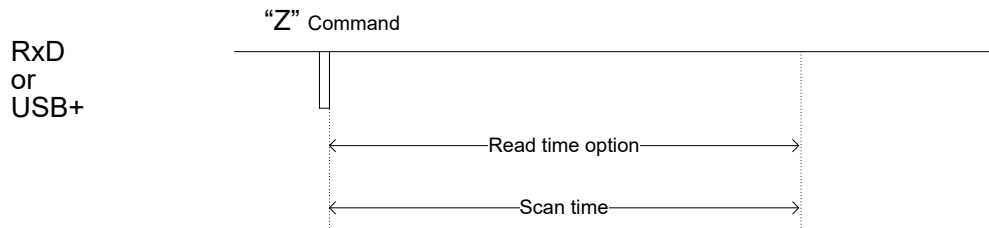

### 5.6.4 Trigger Delay

Trigger delay can start reading from after the trigger delay set time to when the trigger is pressed.

#### Trigger Delay Commands

Command					Description	Default
[DEC	Qa	Qb	Qc	Qd	Trigger delay time (1000a+100b+10c+1d)x[10ms]	0 ms

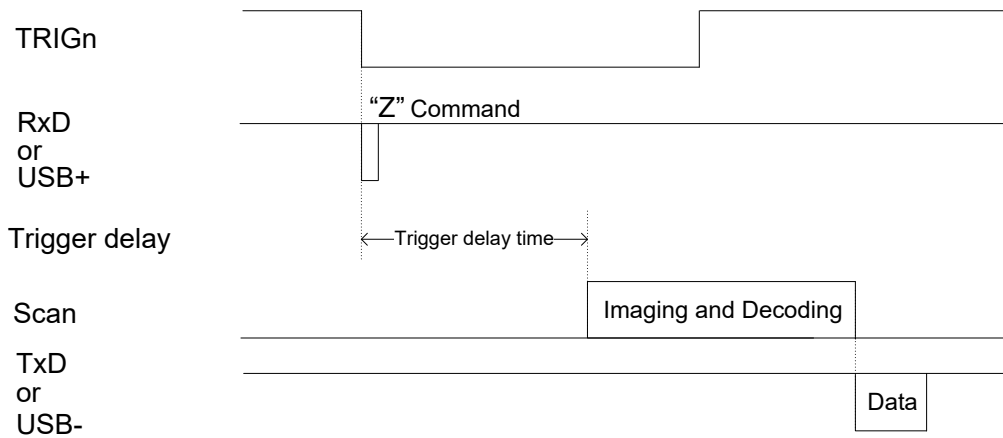

### 5.6.5 Decode Timeout

Decode timeout limits decode processing time for one image. When reading codes continuously, it may take time to decode a poor condition code image and peripheral symbols. In this situation, limiting the time forces the imager engine to decode the next image and may stabilize the reading.

#### Fixed Decode Timeout

Command							Description	Default
[EAV	Q7	Q4	Qa	Qb	Qc	Qd	Fixed decode timeout. (1000a+100b+10c+1d)x[1ms]	0*

\* The default Decode Timeout is up to 700 ms and may end sooner depending on the image.

## 6 Code Options

This chapter describes the code options for the imager engine.

These options allow you to configure the enabled code types, code specific options, and number of characters to be read.

It is strongly recommended to enable only the required codes and options for best reading performance. These settings do not affect the reading of the 1D menu codes.

\* Sample codes for the codes, see "[Sample Code](#)".

### 6.1 [Setting of Readable Codes](#)

#### 6.2 [Setting of Code Common Options](#)

#### 6.3 [Setting of Code Specific Option](#)

#### 6.4 [Setting of Number of Characters](#)

## 6.1 Setting Readable Codes

Symbology commands can be single, multiple, or disabled:

- Single: Only the specified symbology will be enabled. All other symbologies will be disabled.
- Multiple: The specified symbology will be enabled. Any symbologies that are already enabled remain enabled.
- Disabled: The specified symbology will be disabled. Any symbologies that are already enabled remain enabled.

### 6.1.1 1D Codes

Symbology	Enable/Disable Command			Default					
	Single	Multiple	Disable	Enable	Min.Length	Positive/ Negative Image	ST/SP Transmission	CDCheck	Suffix
UPC	J1	R1	[X4B	✓	-	Positive Image Only	-	✓	USB-HID "ENTER"  USB- COM UART "CR"
UPC-A	[J1A	[R1A	[V1A	✓	-		-	✓	
UPC-E	[J1B	[R1B	[V1B	✓	-		-	✓	
EAN/JAN	J4	R4	[X4E	✓	-		-	✓	
EAN/JAN-13	JG	JU	[DDM	✓	-		-	✓	
EAN/JAN-8	JA	JO	[DDN	✓	-		-	✓	
Code 39	A2	B2	VB	✓	1		x	x	
Tri-Optic	JD	JZ	[DDJ	✓	-				
Codabar	A3	B3	VC	✓	2		x	x	
Industrial 2 of 5	J7	R7	[X4K	✓	5		-	x	
Interleaved 2 of 5	J8	R8	[X4L	✓	6		-	x	
S-Code	RA	R9	[DDK		5				
Code 128	A6	B6	VE	✓	1		-	✓	
Code 93	A5	B5	VD	✓	1		-	✓	
IATA	A4	B4	VH	✓	5		-	x	
MSI/Plessey	A7	B7	VF		3		-	✓	
UK/Plessey	A1	B1	VA		2		-	✓	
Telepen	A9	B9	VG		1	-	✓		
Code 11	[BLB	[BLC	[BLA		1	-	✓		
Matrix 2 of 5	AB	BB	[DDL		5	-	x		

\* GS-128 will read as Code 128. For help, see "[GS1 Convert](#)".

**6.1.2 Postal Code**

Symbologies	Enable/Disable Command			Default	
	Single	Multiple	Disable	Enable	Suffix
Chinese Post Matrix 2 of 5	JE	JS	JT		USB-HID "ENTER"
Korean Postal Authority	JL	WH	WI		
Intelligent Mail Barcode	[D5H	[D5F	[D5G		USB-COM UART "CR"
POSTNET	[D6C	[D6A	[D6B		
PLANET	[DG2	[DG3	[DG4		
Japan Postal	[D5R	[D5P	[D5Q		
Netherland KIX Code	[D5M	[D5K	[D5L		
Australian Postal	[D6O	[D6M	[D6N		
UK Postal (Royal mail)	[DG7	[DG8	[DG9		
4-State Mailmark Barcode	[DGS	[DGT	[DGU		

### 6.1.3 GS1 DataBar

Symbologies	Enable/Disable Command						Default	
	Single		Multiple		Disable		Enable	Suffix
GS1 DataBar <ul style="list-style-type: none"> <li>GS1 DataBar Omnidirectional</li> <li>GS1 DataBar Truncated</li> <li>GS1 DataBar Stacked</li> <li>GS1 DataBar Stacked Omnidirectional</li> </ul>	J9	[BC6	JX	[BCI	SJ	[BCU	✓	USB-HID "ENTER"
GS1 DataBar Limited	JJ		JY		SK		✓	USB-COM UART "CR"
GS1 DataBar Expanded <ul style="list-style-type: none"> <li>GS1 DataBar Expanded</li> <li>GS1 DataBar Expanded Stacked</li> </ul>	JK		DR		SL		✓	

\* To convert to GS-1, see "[GS1 Convert](#)".

### 6.1.4 GS1 Composite Code

Symbologies	Enable/Disable Command		Default	
	Multiple	Disable	Enable	Suffix
Composite GS1 DataBar <ul style="list-style-type: none"> <li>CC-A</li> <li>CC-B</li> <li>Limited CC-A</li> <li>Limited CC-B</li> <li>Expanded CC-A</li> <li>Expanded CC-B</li> </ul>	[BHE	[BHF	✓	USB-HID "ENTER"
Composite GS1-128 <ul style="list-style-type: none"> <li>CC-A</li> <li>CC-B</li> <li>CC-C</li> </ul>			✓	USB-COM UART "CR"
Composite EAN <ul style="list-style-type: none"> <li>EAN-13 CC-A</li> <li>EAN-13 CC-B</li> <li>EAN-8 CC-A</li> <li>EAN-8 CC-B</li> </ul>	[D1V	[D1W		
Composite UPC <ul style="list-style-type: none"> <li>UPC-A CC-A</li> <li>UPC-A CC-B</li> <li>UPC-E CC-A</li> <li>UPC-E CC-B</li> </ul>				

\* To convert to GS-1, see "[GS1 Convert](#)".

\* When composite EAN or composite UPC is enabled, EAN or UPC only cannot be read.

## 6.1.5 2D Codes

Symbologies	Enable/Disable command			Default	
	Single	Multiple	Disable	Enable	Suffix
PDF417	[BC3	[BCF	[BCR	✓	USB-HID "ENTER" / USB-COM UART "CR"
MicroPDF417	[BC4	[BCG	[BCS		
Codablock F	[D4R	[D4P	[D4Q		
QR Code	[BC1	[BCD	[BCP	✓	
rMQR Code	[DRG	[DRH	[DRI	✓	
Micro QR	[D38	[D2U	[D2V	✓	
Data Matrix (ECC 200)	[BC0	[BCC	[BCO	✓	
Data Matrix (ECC 000-140)	[BG2	[BG0	[BG1		
Aztec Code	[BC5	[BCH	[BCT	✓	
Aztec Runes	[BF4	[BF2	[BF3		
Chinese-sensible code	[D4K	[D4L	[D4M		
Maxi Code	[BC2	[BCE	[BCQ		
Dot Code	[DOC	[DOD	[DOE		

\* To convert to GS-1 to read GS-1 QR Code and GS1 Data Matrix, see "[GS1 Convert](#)".

## 6.1.6 OCR

### ICAO Machine Readable Travel Documents

Document	Enable/Disable command			Default	
	Single	Enable	Disable	Enable	Suffix
Machine-readable Passports	[DJ1	[DJ2	[DJ3		USB-HID “ENTER” / USB-COM UART “CR”
Machine-readable Visa-A	[DJ4	[DJ5	[DJ6		
Machine-readable Visa-B	[DJ7	[DJ8	[DJ9		
Official Travel Documents 1	[DJA	[DJB	[DJC		
Official Travel Documents 2	[DJD	[DJE	[DJF		

\* ICAO travel documents can be read in any direction, because the format is fixed.

### OCR Free Edit

To free edit standard OCR fonts, see [“OCR Free Edit”](#). For advanced settings, see the “Data Edit Programming Manual”.

## 6.1.7 Code Type Settings

Symbologies	Initialize Command	Enable (Single)	Enable (Multiple)	Disable
All 1D codes	[DX1	[BCA* <sup>1</sup>	[BCM* <sup>1</sup>	[BCY
All 2D codes	[DX2	[BCB	[BCN	[BCZ
All codes (1D, 2D)	[DX0* <sup>2</sup>	A0* <sup>3</sup>		B0

\*1 Add-on code is not enabled.

\*2 OCR will also be initialized.

\*3 OCR and Add-on will not be added.

## 6.2 Setting Code Common Options

### 6.2.1 GS1 Convert

FNC1 that indicate variable length termination will not be transmitted when reading GS1 symbol (GS1-128, GS1 DataBar, GS1 DataBar Composite, GS1 Data Matrix, GS1 QR Code, GS1 Dot Code) label with default setting. This is because FNC1 is not included in ASCII. For GS1 conversion, in order to analyse the GS1 data at the host side, convert valuable length data termination FNC1 to "Ctrl+" and key outputs for USB-HID, and for USB-COM and RS-232C, convert to GS(0x1D) and outputs. However, if the last of valuable length data is AI data, FNC1 does not exist and GS is not outputted.

#### <Initial Setting Status>

<b>FNC1 (Non-output)</b>	AI	Data (Fixed length)	AI Data (Variable length)	<b>FNC1 (Non-output)</b>	...	AI	AI Data (Variable length)
--------------------------	----	---------------------	---------------------------	--------------------------	-----	----	---------------------------



#### <GS1 After Conversion >

For USB-HID

<b>AIM-ID (output)</b>	AI	Data (Fixed length)	AI Data (Variable length)	<b>Ctrl+] (Key output)</b>	...	AI	AI Data (Variable length)
------------------------	----	---------------------	---------------------------	----------------------------	-----	----	---------------------------

For USB-COM and UART

<b>AIM-ID (output)</b>	AI	Data (Fixed length)	AI Data (Variable length)	<b>GS(0x1D) (Output)</b>	...	AI	AI Data (Variable length)
------------------------	----	---------------------	---------------------------	--------------------------	-----	----	---------------------------

\* For AIM-ID, see "[Code Opticon ID](#)".

#### GS1 Conversion

GS1 Conversion Supported Symbolologies	Command	Command Description	Initial Setting
GS1-128	[X/0	Disable GS1 conversion	✓
GS1 DataBar GS1 DataBar Composite GS1 Data Matrix GS1 QR Code GS1 Dot Code	[X/4	Enable GS1 conversion	

To process and output GS1 conversion data within the imager engine, use Opticon's "UniversalConfig" tool.

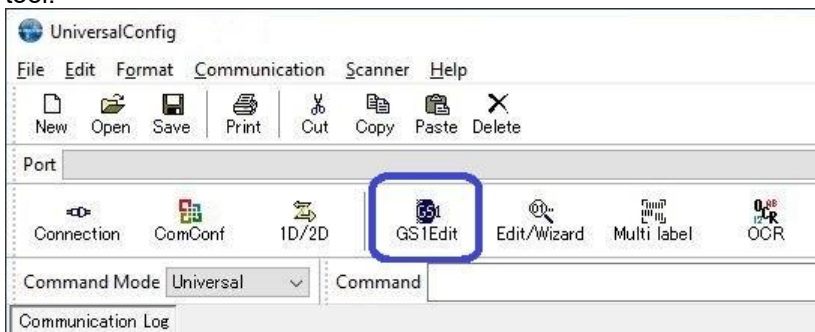

## 6.2.2 Positive and Negative Image of Barcodes (1D Code Common)

Typically, a barcode is printed in black on a white background (normal or positive image). But, if necessary, a barcode can be created as white on a black background (negative image).

Positive Image of Code 128



Negative Image of Code 128

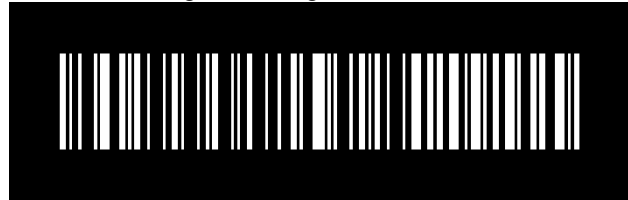

### Positive and Negative 1D Barcode Commands

Command		Description	Default
[DLA]	Q0	Decode positive 1D bar codes only.	✓
	Q1	Decode negative 1D bar codes only.	
	Q2	Decode positive 1D bar codes and negative bar codes.	

\* For optimum reading performance, it is strongly recommended to only enable the required codes and options.

### Positive and Negative PDF417 Commands

Command		Description	Default
[DLB]	Q0	Decode positive PDF417 only.	
	Q1	Decode negative PDF417 only.	
	Q2	Decode positive PDF417 and negative PDF417.	✓

### Positive and Negative QR Code Commands

Command		Description	Default
[DLC]	Q0	Decode positive QR Code only.	
	Q1	Decode negative QR Code only.	
	Q2	Decode positive QR Code and negative QR Code.	✓

### Positive and Negative Data Matrix Commands

Command		Description	Default
[DLD]	Q0	Decode positive Data Matrix only.	
	Q1	Decode negative Data Matrix only.	
	Q2	Decode positive Data Matrix and negative Data Matrix.	✓

### 6.2.3 Smart Quiet Zone (1D Code)

The margin required on the left and right of the barcode is called the quiet zone. If the quiet zone is narrow or the flame line is near, enabling the smart quiet zone will adjust the quiet zone to provide the best performance for reading 1D codes. But, changing this setting does not comply with the barcode standard, so the possibility of misreads may increase. If misreading occurs, disable this setting.

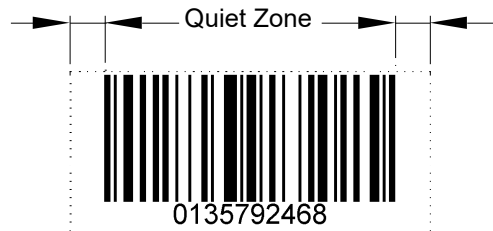

#### Enable/Disable Smart Quiet Zone

Parameter	Command			Description
Enable smart quiet zone	[DLY	Qa	Qb	Enable the code specified by QaQb
Disable smart quiet zone	[DLZ			Disable the code specified by QaQb

#### 1D Barcode Smart Quiet Zone Settings

Symbologies	ab	Default
EAN/UPC	01	✓
Code 39	02	✓
Codabar	03	
Industrial 2 of 5	04	
Interleaved 2 of 5	05	
S-Code	06	
Code128	07	✓
Code93	08	✓
IATA	09	
MSI/Plessey	10	
UK/Plessey	11	
Telepen	12	✓
Code11	13	✓
Matrix 2 of 5	14	
Chinese Post Matrix 2 of 5	15	✓

### 6.2.4 Redundancy (1D Barcode Common)

When redundancy is enabled, a 1D barcode must be scanned and decoded multiple times, and the results must be the same before it is considered correctly decoded. The redundancy count is the number of times that the code must be scanned in addition to the first scan. Selecting a higher redundancy count reduces the probability of reading errors, but slows the output response. With high-quality printed barcodes, the default setting adequately ensures the reading reliability.

**Note:** This setting only affects reading 1D barcodes.

#### Redundancy Commands

Command	Description	Default
X0	Read 1 time, redundancy = 0	
X1	Read 2 times, redundancy = 1	
X2	Read 3 times, redundancy = 2	
X3	Read 4 times, redundancy = 3	✓
BS	Read 5 times, redundancy = 4	
BT	Read 6 times, redundancy = 5	
BU	Read 7 times, redundancy = 6	
BV	Read 8 times, redundancy = 7	
BW	Read 9 times, redundancy = 8	

### 6.2.5 Add-On Waiting Time

The imager engine searches for valid UPC/EAN add-on codes within the selected period of time. If an effective add-on code is found, the imager engine immediately sends the data. If there is no additional information after the code, the imager engine sends data without an add-on. If there is additional information after the code but not a valid add-on code, the imager engine ignores the code.

Supported codes:

- UPC 2 digits/5 digits add-on and GS1 composition symbol
- EAN/JAN 2 digits/5 digits add-on and GS1 composition symbol.

#### Add-On Waiting Time Commands

Command	Description	Initial Setting
XA	Add-on standby mode invalid	
XB	Add-on standby mode 0.25 seconds	
XC	Add-on standby mode 0.5 seconds	✓
XD	Add-on standby mode 0.75 seconds	

## 6.2.6 ECI Protocol Output

ECI protocol output lets you set whether to output data related to ECI (Extended Channel Interpretation) protocol, which is within 2D code (QR Code, Data Matrix, Aztec Code, Maxi Code, Dot Code) data. For data with ECI protocol, the ECI number is indicated by a 6-digit number after the backslash (two backslashes indicate a single backslash).

To not output ECI protocol, change the data career identifier to ID not using ECI protocol, delete the 6-digit number after the backslash and replace the two backslashes with one backslash.

Supported codes:

- QR Code
- Data Matrix
- Aztec Code
- Maxi Code
- Dot Code

Example: ECI Protocol Output



```
Output:      ]Q2\000001test\\test
Not output:  ]Q1test\test
*Back-slash: '\'
```

### ECI Protocol Output Commands

Command	Description	Default
[DLE	Do not output ECI protocol	✓
[DLF	Output ECI protocol	

## 6.2.7 OCR Free Edit

To read OCR standard format, use Opticon's UniversalConfig OCR free edit function.

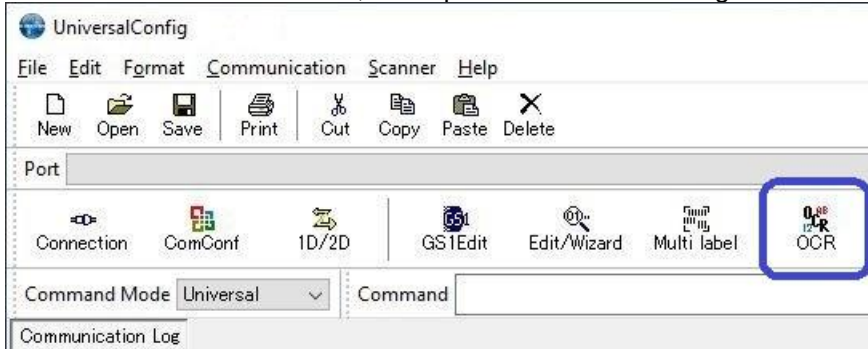

You can set a numerical value, alphabetic character, or symbol of up to 40 digits and 2 rows.

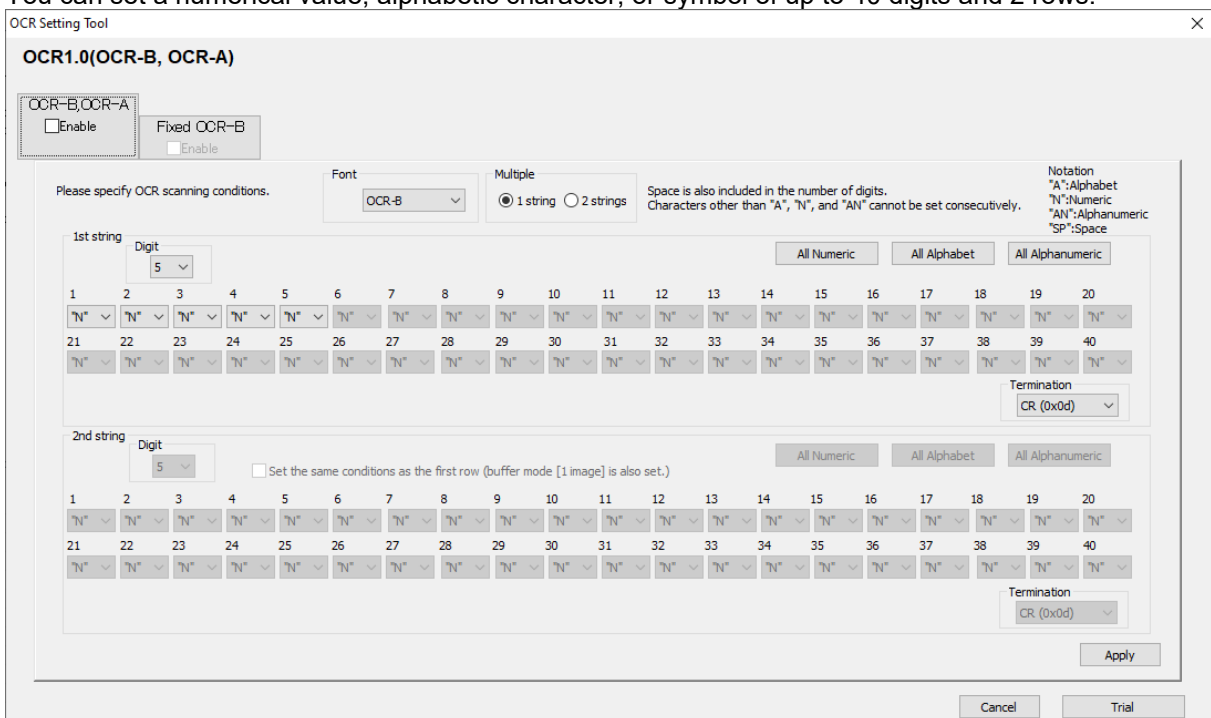

\* For advanced configuration, see the "Data Edit Programming Manual".

\* For options that cannot be set, contact your local sales office.

## 6.2.8 DPM (Dot Peen Making) Code Reading

Use this setting to read codes that are printed on metal or other materials in the dots form by dot peen marking.

DataMatrix in dot print

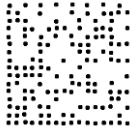

DataMatrix in negative dot print



Normal DataMatrix



Specular reflection or contrast reduction due to materials or marked curved surfaces may prevent the imager engine from successfully reading the code.

### DPM Reading Commands

Command		Description	Default
[DPF	Q0	Do not read DPM patterns.	✓
	Q1	Execute processing of multiple DPM patterns.	
	Q2	Execute processing of multiple DPM patterns and fixate to the process where reading was successful.*	

\* Fixating the DPM pattern process stabilizes the reading.

\* To initialize the fixated process, resend [DPFQ2.

## 6.3 Setting Code Specific Options

### 6.3.1 UPC

UPC is used in the distribution industry and was established by the United States Uniform Code Council Inc.



#### UPC-A Overview

##### UPC-A Parameters

Parameter	Value
Character Set	Numeric (0 - 9)
Number of digits	12 digits (11 digits +CD1 digit) fixed length
CD (Check Digit) Check Method	Modulus 10/Wait 3

Transfer data format

Leading "0"	Data 11 digits	CD 1 digit
-------------	----------------	------------

\* To make the format compatible with JAN/EAN-13, set to 13 digits and transfer a leading "0" and CD.

##### UPC-A Add-On 2 Digits/5 Digits

UPC-A add-on 2 digits/5 digits is a UPC-A barcode plus a 2-digit or 5-digit supplemental code. When add-on is enabled, the add-on code must be within the reading range or the imager engine fails to read. If the add-on code is not within the range, after the add-on waiting time the imager engine reads the barcode as UPC or EAN. When add-on is enable and the imager engine is only reading UPC/EAN, reading response will decrease.

Transfer data format (UPC-A Add-On 2 Digits)

Leading "0"	Data 11 digits	CD 1 digit	Add-on 2 digits
-------------	----------------	------------	-----------------

Transfer data format (UPC-A Add-On 5 Digits)

Leading "0"	Data 11 digits	CD1 digit	Add-on 5 digits
-------------	----------------	-----------	-----------------

##### UPC-A CD Transfer/Front "0" Transfer

UPC-A CD transfer lets you set whether to transmit a CD (check digit) and a leading "0". To make the format compatible with JAN/EAN-13, set to 13 digits and transfer a leading "0" and CD.

## UPC-E Overview



### UPC-E Parameters

Parameter	Value
Character Set	Numeric (0 - 9)
Number of digits	7 digits (6 digits + CD 1 digit) fixed length
CD (Check Digit) Check Method	Modulus 10/Wait 3

#### Transfer data format

Leading "0"	Data 6 digits	CD 1 digits
-------------	---------------	-------------

### UPC-E Add-On 2 Digits/5 Digits

UPC-E Add-on 2 digits/5 digits is a UPC-E barcode plus a 2-digit or 5-digit supplemental code.

#### Transfer data format (UPC-E Add-On 2 Digits)

Leading "0"	Data 6 digits	CD 1 digit	Add-on 2 digits
-------------	---------------	------------	-----------------

#### Transfer data format (UPC-E Add-On 5 Digits)

Leading "0"	Data 6 digits	CD 1 digit	Add-on 5 digits
-------------	---------------	------------	-----------------

### UPC-E CD Transfer/Front "0" Transfer

UPC-E CD Transfer lets you set whether to transmit a CD (check digit) and a leading "0". To make the format compatible with JAN/EAN-8, set to 8 digits and transfer a leading "0" and CD.

You can also convert UPC-E to UPC-A format and transfer.

**UPC-A and UPC-E Commands**

Symbology	Setting	Command	Description	Default
UPC-A	UPC-A Leading zero CD transmission	E2	UPC-A, Leading zero, transmit CD	
		E3	UPC-A, No leading zero, transmit CD	✓
		E4	UPC-A, Leading zero, do not transmit CD	
		E5	UPC-A, No leading zero, do not transmit CD	
	Add-on 2 digits	J2	Enable single UPC Add-on 2	
		R2	Enable UPC Add-on 2	
		[X4C	Disable UPC Add-on 2	✓
	Add-on 5 digits	J3	Enable single UPC Add-on 5	
		R3	Enable UPC Add-on 5	
		[X4D	Disable UPC Add-on 5	✓
	UPC-E	UPC-E Leading zero CD transmission	E6	UPC-E , Leading zero, transmit CD, transfer digits 8 digits
E7			UPC-E , No leading zero, transmit CD, transfer digits 7 digits	✓
E8			UPC-E , Leading zero, do not transmit CD, transfer digits 7 digits	
E9			UPC-E , No leading zero, do not transmit CD, transfer digits 6 digits	
UPC-A, E conversion		6Q	Transmit UPC-E	✓
		6P	Transmit as UPC-A	

### 6.3.2 EAN/JAN

EAN/JAN-13 and EAN/JAN-8 are standardized, common product symbols in the distribution industry. The standard version contains 13 digits and the shortened version contains 8 digits.

#### EAN/JAN-13 Overview

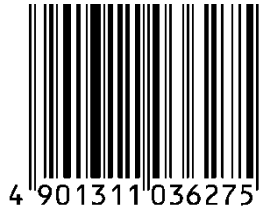

#### EAN/JAN-13 Parameters

Parameter	Value
Character Set	Numeric (0 - 9)
Number of digits	13 digits (12 digits +CD1 digit) fixed length
CD (Check Digit) Check Method	Modulus 10/Wait 3

Transfer data format

Data 12 digits	CD 1 digit
----------------	------------

#### EAN/JAN-13 Add-On 2 Digits/5 Digits

EAN/JAN-13 Add-on 2 digits/5 digits is an EAN/JAN-13 barcode plus a 2-digit or 5-digit supplemental code. When Add-on is enabled, the add-on code must be within the reading range or the imager engine fails to read the barcode. If the add-on code is not within the range, after the add-on waiting time the imager engine reads the barcode as UPC or EAN. When add-on is enabled and the imager engine is only reading UPC/EAN, reading response will decrease.

Transfer data format (EAN/JAN -13 Add-On 2 Digits)

Data 12 digits	CD 1 digit	Add-on 2 digits
----------------	------------	-----------------

Transfer data format (EAN/JAN -13 Add-On 5 Digits)

Data 12 digits	CD 1 digit	Add-on 5 digits
----------------	------------	-----------------

#### EAN/JAN-13 CD Transfer

EAN/JAN-13 CD transfer lets you set whether to transfer EAN/JAN-13 CD (check digit).

**EAN-13 Forced Add-On**

EAN-13 with leading 3 digits (378/379/529/414/419/434/439/977/978) can be forced to handle “with add-on”. When enabled, the barcode without the add-on (the condition of leading 3 digits) cannot be read.

**ISBN Conversion**

When ISBN conversion is enabled, data with the leading 3 digits “978” or “979” is converted. ISBN conversion re-calculates the CD by omitting the leading 3 digits and outputting 10 digits. If the CD is 10, the output is X.

Examples:

- ISBN conversion of EAN-13 “9791230671184”; converts to “1230671188” and outputs.
- ISBN conversion of EAN-13 “9780123782830”; converts to “012378283X” and outputs.

**ISSN Conversion**

When ISSN conversion is enabled, EAN-13 data with a leading “977” is converted. ISSN conversion re-calculates the CD by omitting the leading 3 digits and outputs 8 digits.

**ISMN Conversion**

When ISMN conversion is enabled, EAN-13 data with a leading “9790” is converted. ISMN conversion converts the leading 4 digits to “M” and outputs 10 digits. When ISMN conversion is disabled and ISBN conversion is enabled, EAN-13 data with a leading “9790” will be converted to ISBN format.

Example:

- ISMN conversion of EAN-13 “9790230671187”; converts to “M230671187” and outputs.

## EAN/JAN-8 Overview



### EAN/JAN-8 Parameters

Parameter	Value
Character Set	Numeric (0-9)
Number of digits	8 digits (7 digits + CD1 digit) fixed length
CD (Check Digit) Check Method	Modulus 10/Wait 3

#### Transfer data format

Data 7 digits	CD 1 digit
---------------	------------

### EAN/JAN -8 Add-On 2 Digits/5 Digits

EAN/JAN-8 Add-on 2 digits/5 digits is an EAN/JAN-8 barcode plus a 2-digit or 5-digit supplemental code. When Add-on is enabled, the add-on code must be within the reading range or the imager engine fails to read the barcode. If the add-on code is not within the range, after the add-on waiting time the imager engine reads the barcode as UPC or EAN. When add-on is enabled and the imager engine is only reading UPC/EAN, reading response will decrease.

#### Transfer data format (EAN/JAN-8 Add-On 2 Digits)

Data 7 digits	CD 1 digit	Add-on 2 digits
---------------	------------	-----------------

#### Transfer data format (EAN/JAN-8 Add-On 5 Digits)

Data 7 digits	CD 1digit	Add-on 5 digits
---------------	-----------	-----------------

### EAN/JAN-8 CD Transfer

EAN/JAN-8 CD transfer lets you set whether to transfer EAN/JAN-8 CD (check digit).

### EAN/JAN-13 Optional Settings

Symbology	Setting	Command	Description	Default
EAN/JAN-13	CD Transmission	6K	Transmit EAN/JAN -13 CD	✓
		6J	Do not transmit EAN/JAN-13 CD	
	Add-on 2 digits	JH	Singly enable EAN/JAN -13 Add-on 2 digits	
		JV	Add enable EAN/JAN -13 Add-on 2 digits	
		[X4N	Disable EAN/JAN -13 Add-on 2 digits	
	Add-on 5 digits	JI	Singly enable EAN/JAN -13 Add-on 5 digits	
		JW	Add enable EAN/JAN -13 Add-on 5 digits	
		[X4P	Disable EAN/JAN -13 Add-on 5 digits	
	EAN-13	EAN-13 Forced add-on	-G	When EAN-13 starts with 378/ 379/529; Enable EAN forced add-on
-H			When EAN-13 starts with 378/ 379/529; Disable EAN forced add-on	✓
-C			When EAN-13 starts with 434/439/414/419/977/978; Enable EAN forced add-on	
-D			When EAN-13 starts with 434/439/414/419/977/978; Disable EAN forced add-on	✓
ISBN Conversion		IB	Disable ISBN conversion	✓
		IA	Enable ISBN conversion	
		IK	When possible, enable ISBN conversion	
ISSN Conversion		HN	Disable ISSN conversion	✓
		HO	Enable ISSN conversion	
		4V	When possible, enable ISSN conversion	
ISMN Conversion		IO	Disable ISMN conversion	✓
		IP	Enable ISMN conversion	
		IQ	When possible, enable ISMN conversion	

### EAN/JAN-8 Optional Settings

Symbology	Setting	Command	Description	Default
EAN/JAN-8	CD Transmission	6I	Transmit EAN/JAN-8 CD	✓
		6H	Do not transmit EAN/JAN-8 CD	
	Add-on 2 digits	JB	Singly enable EAN/JAN-8 Add-on 2 digits	
		JP	Add enable EAN/JAN-8 Add-on 2 digits	
		[X4M	Disable EAN/JAN-8 Add-on 2 digits	
	Add-on 5 digits	JC	Singly enable EAN/JAN-8 Add-on 5 digits	
		JQ	Add enable EAN/JAN-8 Add-on 5 digits	
		[X4O	Disable EAN/JAN-8 Add-on 5 digits	

### 6.3.3 Code 39 and It. Pharm

Code 39 is a barcode developed by Intermecc and has been standardized as ISO/IEC 16388. Code 39 is mainly used in industrial fields.

#### Code 39 Overview



CODE39

#### Code 39 Parameters

Parameter	Value
Character Set	Numeric (0 - 9) Symbol (- , Space \$/+ %) Alphabet (A to Z)
Start/Stop code	*
Digits	Variable length

#### Transfer data format

Start code “*”	Data Variable length	CD	Stop code “*”
-------------------	----------------------	----	------------------

#### Code 39 Settings

Setting	Description
Calculate Code 39 CD	Determines if checking the CD (check digit) is configurable.
Transfer Code 39 CD	Determines if transferring the CD (check digit) is configurable.
Transfer Code 39 Start/Stop Code	Determines if transferring the Start/Stop code is configurable.
Code 39 Various Conversion Settings	<ul style="list-style-type: none"> <li>• Standard Code 39: Send data character as is.</li> <li>• Full ASCII Code 39: Converts the correct combination of the data character to Full ASCII and transmits it. If an incorrect combination is found in the character, it will not be transmitted.</li> <li>• When possible Full ASCII Code 39: Converts the specified combination of the data character to Full ASCII and transmits it. An incorrect combination will be transmitted without converting, as is.</li> <li>• Italian Pharmaceutical: Converts Code 39 data to Italian Pharmaceutical format, which is fixed-length and contains a 1-digit mandatory check digit after 8 digits of numeric data. When not adapting to Italian Pharmaceutical, it will not be sent.</li> <li>• When possible Italian Pharmaceutical: Converts Code 39 data to Italian Pharmaceutical format. When not adapting to Italian Pharmaceutical, it will be sent as standard Code 39.</li> </ul>

**Code 39 It. Pharm Optional Settings**

Setting	Command	Description	Default
CD Check	C1	Do not check CD	✓
	C0	Check CD	
CD Transmission	D9	Transmit Code 39 CD	✓
	D8	Do not transmit Code 39 CD	
ST/SP Transmission	D1	Do not transmit ST/SP	✓
	D0	Transmit ST/SP	
Full ASCII Conversion	D5	Normal Code 39	✓
	D4	Full ASCII Code 39	
	+K	Full ASCII Code 39, if possible	
It. Pharm	D6	It. Pharmaceutical, only	
	D7	It. Pharmaceutical, if possible	
	DA	Do not transmit leading A for It. Pharm	✓
	DB	Transmit leading A for It. Pharm	
Concatenation	+M	Disable concatenation	✓
	+L	Enable concatenation	

### 6.3.4 Codabar

Codabar is a relatively early-stage barcode developed by Monarch Marking Company in 1972 following 2 of 5.



#### Codabar Parameters

Parameter	Value
Character Set	Numeric (0 - 9) Symbol (- \$ :/, +)
Start/Stop Code	A, B, C, or D
Digits	Variable length
CD (Check Digit) Check Method	Check digits are typically not used.

#### Transfer data format

Start code 1 digit	Data Variable length	CD	Stop code 1 digit
--------------------	----------------------	----	-------------------

#### Codabar Settings

Setting	Description
Codabar (NW-7) Read Mode	<ul style="list-style-type: none"> <li>Standard mode: Consists of one barcode.</li> <li>ABC mode: ABC is an acronym for the American Blood Commission. This mode consists of two side-by-side barcodes (a margin is necessary). When the barcode's first stop character and the second start character is D, it will be concatenated and sent. Two D characters will not be sent.</li> <li>CX mode: Consists of 2 side-by-side barcodes (a margin is necessary). When the barcode's first stop character is C and the second start character is B, it will be concatenated and sent. B and C characters will not be sent.</li> </ul>
Codabar CD Check	In Codabar, Modulus 16 is typically used.
Codabar CD Transfer	Determines if transferring the CD (check digit) is configurable.
Start/Stop Code Transfer	Determines if transferring the start/ stop code is configurable. The code can also be converted and transferred when transferring the start/stop code.

**Codabar Optional Settings**

Setting	Command	Description	Default
CD Check	H7	Do not check CD	✓
	H6	Check CD	
CD Transmission	H8	Transmit Codabar CD	✓
	H9	Do not transmit Codabar CD	
ST/SP Transmission	F0	Do not transmit Start/Stop code	✓
	F1	Start/Stop code: ABCD/TN*E	
	F2	Start/Stop code: abcd/tn*e	
	F3	Start/Stop code: ABCD/ABCD	
	F4	Start/Stop code: abcd/abcd	
	HJ	Start/Stop code: <DC1><DC2><DC3><DC4> /<DC1><DC2><DC3><DC4>	
Space Insertion	HE	Disable space insertion	✓
	HD	Enable space insertion	
ABC, CX Conversion	HA	Enable only Codabar normal mode	✓
	H4	Enable only ABC code	
	H5	Enable only CX code	
	H3	Enable Codabar/ABC and CX	

### 6.3.5 Interleaved 2 of 5

Interleaved 2 of 5 is a symbol standardized by ISO/IEC 16390 as the standard distribution symbol ITF.

#### Interleaved 2 of 5 Overview

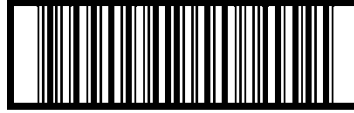

14901234567891

#### Interleaved 2 of 5 Parameters

Parameter	Value
Character Set	Numeric (0 - 9)
Start/Stop Code	Hidden character
Digits	Variable length (even number)
CD (Check Digit) Check Method	Modulus 10/Wait 3

Transfer data format

Data variable length	CD
----------------------	----

#### Interleaved 2 of 5 Settings

Setting	Description
Interleaved 2 of 5 CD Check	Determines if checking the CD (check digit) is configurable. This setting also configures whether to check the CD for Interleaved 2 of 5, Industrial 2 of 5, S-Code, and Matrix 2 of 5 CD.
Interleaved 2 of 5 CD Transmit	Determines if transferring the CD (check digit) is configurable. This setting also configures whether to transfer the CD for Interleaved 2 of 5, Industrial 2 of 5, S-Code, and Matrix 2 of 5.
Industrial 2 of 5 Space Check	Determines whether to enable or disable the space (inter-character gap) check for Industrial 2 of 5.

#### Interleaved 2 of 5 Settings and Optional Settings

Setting	Command	Description	Default
CD Check	G0	Do not check CD	✓
	G1	Check CD	
CD Transmission	E0	Transmit CD	✓
	E1	Do not transmit CD	
Space Check	GK	Disable space check for Industrial 2 of 5	
	GJ	Enable space check for Industrial 2 of 5	✓
S-Code Conversion	GH	Do not transmit S-Code as Interleaved 2 of 5	✓
	GG	Transmit S-Code as Interleaved 2 of 5	

### 6.3.6 Code128

Code128 is developed by Computer Identix Inc. in the USA in 1981. Code128 is a symbol standardized as USS-CODE128. Because it can encode ASCII128 characters, it is called Code128.

#### Code128 Overview



#### Code128 Parameters

Parameter	Value
Character Set	ASCII128 character Function character (FNC1 – 4) Code set selection character (A, B, C and Shift)
Start/Stop Code	Hidden character Start pattern 3 types (A, B, and C), Stop pattern 1 type
Digits	Variable length
CD (Check Digit) Check Method	Modulus 103

#### Transfer data format

Data (variable length)
------------------------

#### Code 128 Settings

Setting	Description
GS1 Conversion	You can disable or enable GS1-128 GS1 conversion. For help, see <a href="#">“GS1 Convert”</a> .
Concatenation of Code 128	<p>When Code128 data has a leading FNC2 character, you can configure whether to concatenate the data.</p> <p>When reading a barcode with a leading FNC2 character, you can concatenate the data by omitting the leading FNC2.</p> <p>When reading a barcode that does not have a leading FNC2 character, the data is concatenated to the end of the data that is buffering to the imager engine, and the entire buffer is sent.</p> <p>The reading time is updated every time a label is read. But, if the reading is not completed within the reading time, the buffered data will be discarded.</p> <p>A maximum of 400 characters can be concatenated at a time.</p>

#### Code 128 Optional Parameters

Parameter	Command	Description	Default
GS1 Conversion	OF	Disable GS1-128	✓
	JF	Enable GS1-128, only	
	OG	Enable GS1-128, if possible	
Concatenation	MP	Disable concatenation	✓
	MO	Enable concatenation	

### 6.3.7 IATA

Parameter	Command	Description	Default
CD Check	4H	Do not check CD	✓
	4I	Check FC/SN, only	
	4J	Check FC/CPN/SN	
	4K	Check FC/CPN/AC/SN	
CD Transmission	4M	Do not transmit CD	
	4L	Transmit CD	✓

### 6.3.8 MSI/Plessey

Parameter	Command	Description	Default
CD Check	4A	Do not check CD	
	4B	Check 1 CD = MOD 10	✓
	4C	Check 2 CD = MOD 10/MOD 10	
	4D	Check 2 CD = MOD 10/MOD 11	
	4R	Check 2 CD = MOD 11/MOD 10	
	4S	Check 2 CD = MOD 11/MOD 11	
CD Transmission	4G	Do not transmit CD	
	4E	Transmit CD 1	✓
	4F	Transmit CD 1 and CD 2	

### 6.3.9 UK/Plessey

Parameter	Command	Description	Default
CD Transmission	4O	Do not transmit CD	
	4N	Transmit CD	✓
Space Insertion	DO	Disable space insertion	✓
	DN	Enable space insertion	
X Conversion	DP	Conversion A -> X disabled	✓
	DQ	Conversion A -> X enabled	

### 6.3.10 Telepen

Parameter	Command	Description	Default
Conversion Output Mode	D2	Numeric mode	ü
	D3	ASCII mode	

### 6.3.11 Code 11

Parameter	Command	Description	Default
CD Check	BLF	Do not check CD	
	BLG	Check 1 CD	
	BLH	Check 2 CD	
	BLI	Check auto 1 or 2 CD	✓
CD Transmission	BLJ	Do not transmit CD	✓
	BLK	CD transmit	

### 6.3.12 Korean Postal Authority

Parameter	Command	Description	Default
CD Transmission	*+	CD transmit	
	*-	Do not transmit CD	✓
Transmit Dash	*.	Transmit dash	✓
	*/	Do not transmit dash	
Upside-Down Reading	*9	Upside-down reading enabled	
	*8	Upside-down reading disabled	✓

### 6.3.13 GS1 DataBar

GS1 DataBar (formerly RSS) is a relatively new symbol developed close to GS1 and standardized by ISO/IEC 24724:2011. It has 3 types and 7 kinds. GS1 DataBar can be expressed in a relatively small space.

#### GS1 DataBar Overview



#### GS1 DataBar Parameters

Parameter	Value
Character Set	GS1 DataBar Omnidirectional and GS1 DataBar Limited: Numeric (0 - 9) GS1 DataBar Expanded: capital/small character alphabet, numbers, 20 types symbol, function character (FNC1)
Digits	GS1 DataBar Omnidirectional and GS1 DataBar Limited: Application identifier "01" and 14 digits GS1 DataBar Expanded: number 74 digits and alphabet 41 digits
Check sum	Check sum is always checked but not sent. GS1 DataBar Omnidirectional: Modulus 79 GS1 DataBar Limited: Modulus 89 GS1 DataBar Expanded: Modulus 211
CD check	GS1 DataBar Omnidirectional and GS1 DataBar Limited: Modulus 10/ Wait 3

Transfer data format (GS1 DataBar Omnidirectional, GS1 DataBar Limited)

AI "01"	Data (13 digits)	CD (1 digit)
---------	------------------	--------------

Transfer data format (GS1 DataBar Expanded)

Data (1 - 74 digits)
----------------------

#### GS1 Data Bar Settings

Setting	Description
GS1 Conversion	You can disable or enable GS1 conversion. For help, see " <a href="#">GS1 Convert</a> ".

### 6.3.14 GS1 DataBar Composite

Composite GS1 is a code developed by GS1 for medical use. It is standardized and registered by ISO/IEC 24723. The symbol can be combined with GS1 DataBar, GS1-128, and UPC/EAN. In the market, other than Composite, GS1 DataBar is rarely used.

#### Composite GS1 DataBar Overview

(17) 201607 (10) ABCCA  
  
 (01) 1 4512345 67890 3

#### Composite GS1 Parameters

Parameter	Value
Character Set	ASCII value 0 - 127 (ISO 646) ASCII value 128 - 255 (ISO 8859, Alphabet No.1, Extend ASCII) Using ECI: many other character sets
Composite	CC-A is a revised version of MicroPDF417. CC-B is normal MicroPDF417. CC-C is normal PDF417.
Maximum Digits	CC-A: 56 characters CC-B: 338 characters CC-C: 2361 characters
Symbol Size	1D part: see GS1 DataBar and UPC/EAN Composite part: CC-A and CC-B are same as MicroPDF417. CC-C is same as PDF417
Error Correction	1D part: error detection only Composite part: Reed Solomon error correction
Link Flags	GS1 DataBar and GS1 128 composite have link flags. UPC/EAN composite does not have link flags.

#### Transfer data format (CC-A)

1D data (1 – 74 digits)	Composite data (1 – 56 digits)
-------------------------	--------------------------------

#### Transfer data format (CC-B)

1D data (1 – 74 digits)	Composite data (1 – 338 digits)
-------------------------	---------------------------------

#### Transfer data format (CC-C)

1D data (1 – 74 digits)	Composite data (1 – 2361 digits)
-------------------------	----------------------------------

#### GS1 Data Bar Composite Settings

Setting	Description
GS1 Conversion	You can disable or enable GS1 conversion. For help, see <a href="#">“GS1 Convert”</a> .

### 6.3.15 PDF417

PDF417 is a stack type code developed by Symbol Technology Inc. and is used for international logistics, ID cards (overseas), and parts labels. PDF417 is standardized in ISO/IEC 15438:2006.

#### PDF417 Overview



PDF417 sample



Micro PDF417 sample

#### PDF417 Parameters

Parameter	Value
Character Set	ASCII value 0 – 127 (ISO 646) ASCII value 128 – 255 (ISO 8859-1, Alphabet No.1, Extended ASCII) For Macro PDF 417: many other character sets
Maximum Digits (PDF417)	Text compression: 1850 character Byte compression: 1108 character Numeric compression: 2710 character
Maximum Digits (MicroPDF417)	Text compression: 250 characters Byte compression: 150 characters Numeric compression: 366 characters
Symbol Size (PDF417)	Number of lines: 3 – 90 Number of rows: 1 - 30
Symbol Size (MicroPDF417)	Number of lines: 4 – 44 Number of rows: 1 - 4
Error Correction (PDF417)	Error correction level 8. The option for error detection only.
Error Correction (MicroPDF417)	Number of code words for error correction is fixed by the symbol and cannot be changed.

#### Transfer data format

Data (variable length)
------------------------

#### PDF417 Settings

Setting	Description
MicroPDF417	Default is invalid. For help, see " <a href="#">2D Codes</a> ".

### 6.3.16 QR Code

QR Code is a matrix type 2D code developed by DENSO WAVE INC. and standardized by SO/IEC 18004:2000. QR Code supports high-speed reading and is used in a wide variety of fields.

#### QR Code Overview



QR Code

#### QR Code Parameters

Parameter	Value
Character Set	Numeric data (Numbers 0-9) Alphanumeric data (Numbers 0-9, Capital letter A-Z, 9 special characters: space, \$, %, *, +, -, ., /, :) 8-bit byte data (Latin character based on JIS X 0201, character set of 8 bit code for Katakana character.) Chinese character (character specified by the shift-coded expression of JIS X 0208)
Maximum Digits	Alphanumeric data: 4296 characters 8-bit data: 2953 characters Numeric data: 7089 characters Chinese character data: 1817 characters
Symbol Size	Minimum: 21 x 21 module Maximum: 177 x 177 module
Error Correction	Reed Solomon error correction level 4 L:7% M:15% Q:25% H:30%
Negative Barcode, Mirror Printing	Negative and mirror printed QR Code are readable.
Concatenated Code	Outputs after reading all concatenated codes.

#### Transfer data format

Data (variable length)
------------------------

#### QR Code Settings

Setting	Description
GS1 Conversion	You can disable or enable GS1 conversion. For help, see <a href="#">“GS1 Convert”</a> .
ECI Protocol Output	You can disable or enable the output of ECI protocol data. For help, see <a href="#">“ECI Protocol Output”</a> .

## rMQR Code Overview



rMQR Code

### rMQR Code Parameters

Parameter	Value
Character Set	Numeric data (numbers 0-9) Alphanumeric data (numbers 0-9, capital characters A-Z, 9 special characters: space, \$, %, *, +, -, ., /, :) 8-bit byte data (Latin character based on JIS X 0201, character set of 8-bit code for Katakana characters) Chinese character (character specified by the shift-coded expression of JIS X 0208)
Maximum Digits	Alphanumeric data: 219 characters 8-bit data: 150 characters Numeric data: 361 characters Chinese character data: 92 characters
Symbol Size	Minimum height: 7×43 modules Minimum width: 11×27 modules Maximum: 17×139 modules
Negative Barcode, Mirror Printing	Negative and mirror printed rMQR Codes are readable
Error Correction	Reed Solomon error correction level 2 M:15% H:30%

### Transfer data format

Data (variable length)
------------------------

### rMQR Code Settings

Setting	Description
GS1 Conversion	You can disable or enable GS1 conversion. For help, see <a href="#">“GS1 Convert”</a> .
ECI Protocol Output	You can disable or enable the output of ECI protocol data. For help, see <a href="#">“ECI Protocol Output”</a> .

## Micro QR Code Overview



Micro QR

### Micro QR Code Parameters

Parameter	Value
Character Set	Numeric data (numbers 0-9) Alphanumeric data (numbers 0-9, capital characters A-Z, 9 special characters: space, \$, %, *, +, -, ., /, :) 8-bit byte data (Latin character based on JIS X 0201, character set of 8-bit code for Katakana characters) Chinese character (character specified by the shift-coded expression of JIS X 0208)
Maximum Digits	Alphanumeric data: 21 characters 8 bit data: 15 characters Numeric data: 35 characters Chinese character data: 9 characters
Symbol Size Error Correction	Version M1: 11 x 11 module – Error detection only Version M2: 13 x 13 module – Reed Solomon error correction 2 steps(L, M) Version M3: 15 x 15 module – Reed Solomon error correction 2 steps(L, M) Version M4: 17 x 17 module – Reed Solomon error correction 3 steps (L, M, Q)
Negative Barcode, Mirror Printing	Negative and mirror printed QR Codes are readable.

### Transfer data format

Data (variable length)
------------------------

### 6.3.17 Data Matrix

Data Matrix is a matrix type 2D code developed by Idymatrix Corporation and is standardized by ISO/IEC 16022. Data Matrix has an L-shaped finder and a symbol that can be reduced in size. Data Matrix is mainly used for industrial environments.

#### Data Matrix Overview



#### Data Matrix Parameters

Parameter	Value
Character Set	ASCII value 0 – 127 (ISO 646) ASCII value 128 – 255 (ISO 8859-1, Alphabet No.1, Expand ASCII) Using ECI: many other character sets
Maximum Digits (ECC200 Square)	Alphanumeric data: 2335 characters 8-bit data: 1556 characters Numeric data: 3116 characters
Maximum Digits (ECC200 Rectangle)	Alphanumeric data: 98 characters 8-bit data: 47 characters Numeric data: 72 characters
Symbol Size (ECC200)	Even rows and even columns, square or rectangle Square: minimum 10 x 10, maximum 144 x 144 module Rectangle: minimum 8 x 18, maximum 16 x 48 module (6 patterns)
Error Correction (ECC200)	Set automatically
Negative Barcode, Mirror Printing	Negative and mirror printed Data Matrix are readable

#### Transfer data format

Data (variable length)
------------------------

#### Data Matrix Settings

Setting	Description
ECC 000-140	You can disable or enable ECC 000-140. By default, this setting is disabled.
GS1 Conversion	You can disable or enable GS1 conversion. For help, see <a href="#">“GS1 Convert”</a> .
ECI Protocol Output	You can disable or enable the output of ECI protocol data. For help, see <a href="#">“ECI Protocol Output”</a> .

### 6.3.18 Aztec Code

Aztec Code is a matrix type 2D code developed by Welch Allyn Company and is mainly used in tickets and the medical industry. Aztec Code does not require a surrounding blank “quiet zone.”

#### Aztec Code Overview



Aztec code

#### Aztec Code Parameters

Parameter	Value
Character Set	ASCII value 0 – 127 (ISO 646) ASCII value 128 – 255 (ISO 8859-1, Alphabet No.1, Expand ASCII) Using ECI: many other character sets
Maximum Number of Digits	Alphanumeric data: 3067 characters Number: 3832 characters Byte: 1914 character
Symbol Size	Minimum: 15 x 15 module Maximum: 151 x 151 module
Error Correction	The selectable error correction level is 5% to 95% of the data area.

#### Transfer data format

Data (variable length)
------------------------

#### Aztec Code Settings

Setting	Description
ECI Protocol Output	You can disable or enable the output of ECI protocol data. For help, see “ <a href="#">ECI Protocol Output</a> ”.

## 6.4 Setting the Number of Characters

To read fixed length codes, configure the imager engine for the fixed number of characters. The imager engine verifies that the codes are the correct length and rejects codes that are not the specified length. Setting a fixed length protects against false short scans of codes that may occur with code types that do not provide sufficient security against partial scans (e.g. Interleaved 2 of 5). Length checking is done on the code data and is not affected by options such as “do not transmit start/stop character or check digit.” Setting the number of characters does not affect fixed length codes, such as EAN-13.

### 6.4.1 Fixed Length ON, Minimum/Maximum Length for Selected Codes

This option enables fixed length and minimum/maximum length checking for each code type and only affects the specified code types.

#### Fixed Length Commands

Command		Description	Default(Valid Range)
Specify Code	Input length of digits	Fixed length for selected codes  Length: (1000a+100b+10c+d)	(0 - 8000)
See <a href="#">“Command List: Fixed Length ON/Minimum/Maximum Length”</a> .	Qa   Qb   Qc   Qd		

#### Configuration Examples

Configuration	Command
Fix Code 39 length to 6 digits	<ESC>[DC1Q6<CR>
Fix Code 39 length to 6 digits and 12 digits	<ESC>[DC1Q0Q0Q0Q6Q0Q0Q1Q2<CR>
Fix Code 39 length to 6 digits and Interleaved 2 of 5 to 12 digits	<ESC>[DC1Q6[DC4Q1Q2<CR>
Fix Code 39 length to 6 digits and Interleaved 2 of 5 to 12 digits	<ESC>[DC1Q6[DC4Q1Q2<CR>
Clear fixed length for Code 39	<ESC>[DC1<CR>
Set minimum length for Interleaved 2 of 5 to 4 digits	<ESC>[DB4Q4<CR>
Clear minimum length for Interleaved 2 of 5	<ESC>[DB4<CR>
Set maximum length for Code 39 to 12 digits	<ESC>[DA1Q1Q2<CR>
Clear maximum length for Code 39	<ESC>[DA1<CR>
Set maximum length for PDF417 to 20 digits and QR Code to 125 digits	<ESC>[DALQ2Q0[DAJQ1Q2Q5<CR>

### 6.4.2 Command List: Fixed Length ON/Minimum/Maximum Length

To set the length, enter the command followed by a value. When you reset the settings, the length that is currently set becomes the default.

Code Type	Fixed Length	Min. Length	Max. Length
Reset Settings	[DC0	[XQG	[XNG
Code 39	[DC1	[DB1	[DA1
Codabar	[DC2	[DB2	[DA2
Industrial 2 of 5	[DC3	[DB3	[DA3
Interleaved 2 of 5	[DC4	[DB4	[DA4
Code 93	[DCD	[DBD	[DAD
Code 128	[DCB	[DBB	[DAB
MSI/Plessey	[DC8	[DB8	[DA8
IATA	[DC7	[DB7	[DA7
PDF417	[DCL	[DBL	[DAL
QR Code	[DCJ	[DBJ	[DAJ
Data Matrix	[DCH	[DBH	[DAH
Dot Code	[DCU	[DBU	[DAU
Maxi Code	[DCK	[DBK	[DAK
Aztec Code	[DCI	[DBI	[DAI
MicroPDF417	[DCM	[DBM	[DAM
RSS-Expanded (GS1 DataBar)	[DCF	[DBF	[DAF
Composite	[DCG	[DBG	[DAG
GS1-128	[DCC	[DBC	[DAC
S-Code	[DC5	[DB5	[DA5
UK/Plessey	[DCA	[DBA	[DAA
Matrix 2 of 5/Chinese Post	[DC6	[DB6	[DA6
Telepen	[DC9	[DB9	[DA9
Codablock F	[DCO	[DBO	[DAO
Code 11	[DCE	[DBE	[DAE
Chinese Sensible Code	[DCN	[DBN	[DAN

## **7 String Options**

This chapter describes the alterations which can be made to the transmitted data string.

The configurations available are:

### **7.1 [Case Conversion](#)**

#### **7.2 [Prefix / Suffix \(Appending Characters\)](#)**

## 7.1 Case Conversion

The decoded data may be converted to either all lower case or all upper case characters, or the case may be changed. Use these options if the host only requires upper or lower case characters.

### Example: Upper Case/Lower Case Conversion

Description	AbCd	Default
No case conversion	AbCd	✓
Convert to upper case	ABCD	
Convert to lower case	abcd	
Exchange case	aBcD	

### Case Conversion Commands

Command	Description	Default
YZ	No case conversion	✓
YW	Convert to upper case	
YX	Convert to lower case	
YY	Exchange case	

## 7.2 Prefix/Suffix (Appending Characters)

You can place informational characters just before the decoded data (pre-data) or transmit them immediately after the data (post-data).

Output Format:

- Prefix/Suffix (up to 4 digits): Specified characters can be added in front of or at the end of the data for each specific symbology. By default, the prefix is empty and the suffix for all codes is the “CR” character. You cannot set prefix/suffix when using OCR Free Edit or Data Edit Reading. For help, see [“OCR Free Edit”](#) and [“Data Edit Reading”](#).
- Preamble/Postamble (up to 8 digits): Specified characters can be added in front of or at the end of the data for all codes. By default, they are empty.

Preamble	Prefix for each code	Decoded Data	Suffix* <sup>1</sup> for each code	Postamble
Max. 8 digits	Max. 4 digits		Max. 4 digits	Max. 8 digits

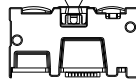

\*<sup>1</sup> By default, <CR> is added to suffix for all codes with the “RZ” command.

### Appended Data

Data	Description
ASCII	All 128 characters.
Code ID	Transmitted in OPTICON ID, ISO15424 standard or AIM-ID.
Code Length	The number of characters after the output format. For help, see <a href="#">“Setting Code Specific-Options”</a> .
Code Coordinate	Transmitted as the pixel coordinate of the image sensor.
Code Tilt Angle	The tilt angle of the read code can be added to the prefix and suffix.
Scan Time	The time from when the trigger is pressed until data output starts.
Bank Number	The current operating bank number can be added to the prefix and suffix.

## 7.2.1 Set Prefix/Suffix Prefix/Suffix Commands

Command		Description	Default
Set Commands	Value Commands	Set character to Prefix/Suffix	All codes Suffix
See <a href="#">“Command List; Prefix/Suffix Settings”</a> .	ASCII: See <a href="#">“ASCII (Prefix/Suffix Values)”</a> .		USB-HID: “Enter”
	<a href="#">Code ID</a> : See <a href="#">“Code ID”</a> .		USB-COM: “CR”
	<a href="#">Code Length</a> : See <a href="#">“Code Length”</a> .		UART: “CR”
	<a href="#">Code Coordinates</a> : See <a href="#">“Code Coordinates”</a> .		
	<a href="#">Code Tilt Angle</a> : See <a href="#">“Code Tilt Angle”</a> .		
	Scan Time: See <a href="#">“Scan Time”</a> .		
	Bank Number: See <a href="#">“Bank Number”</a> .		

Example:

Set “C39:” as the prefix and “CR” and “LF” as the suffix for Code 39.

Command: <ESC>M40CQ3Q96AO41M1J<CR>

### Notes:

- You can also set the Prefix/Suffix with a menu barcode or 2D menu code.
- The prefix and suffix setting commands clear the current values and configure new ones. The default suffix “CR” is also cleared.
- To clear the default suffix “CR”, scan the RZ menu code (set suffix for all codes) without codes for the suffix or scan the PR menu code (clear suffix).
- When the number of configured prefix/suffix characters exceeds the maximum limit (4 digits), the configuration is ignored.

## 7.2.2 Command List: Prefix/Suffix Settings

By default, “CR” (“Enter” for USB-HID) is added to the suffix for all codes.

### All Barcodes Prefix/Suffix Commands

Barcode	Prefix Command	Suffix Command
All barcodes	RY	RZ

\*To clear “CR” or “Enter”, send the “RZ” command, only.

### Barcode Prefix/Suffix Commands

Barcode	Prefix Command	Suffix Command
UPC-A	N1	N6
UPC-A add-on	M0	O0
UPC-E	N2	N7
UPC-E add-on	M1	O1
EAN-13	N3	N8
EAN-13 add-on	M2	O2
EAN-8	N4	N9
EAN-8 add-on	M3	O3
Code 39	M4	O4
Tri-optic	MC	PN
Codabar	M5	O5
Industrial 2 of 5	M6	O6
Interleaved 2 of 5	M7	O7
S-Code	MB	OB
Matrix 2 of 5	GL	GM
Chinese Post Matrix 2 of 5		
IATA	I8	I9
MSI/Plessey	N0	N5
Telepen	L8	L9
UK/Plessey	MA	OA
Code 128	M9	O9
GS1-128	[XMX	[XOX
Code 11	[BLD	[BLE
Korean Postal Authority	*\$	*%

**Barcode Prefix/Suffix Commands (continued)**

Barcode	Prefix Command	Suffix Command
Intelligent Mail Barcode	[D5I	[D5J
POSTNET	[D6D	[D6E
PLANET	[DG5	[DG6
Japan Postal	[D5S	[D5T
Netherlands Kix Code	[D5N	[D5O
UK Postal (Royal Mail)	[DGA	[DGB
4-State Mailmark Barcode	[DGV	[DGW
Australian Postal	[D6P	[D6Q
GS1 DataBar	OE	PQ
GS1 DataBar	[D6J	[D6G
GS1 DataBar Limited	[D6K	[D6H
GS1 DataBar Expanded	[D6L	[D6I
GS1 Composite Code	RR	RS
Codablock F	[D4S	[D4T
Data Matrix	MD	PO
Dot Code	[DOF	[DOG
Aztec	[BF0	[BF1
Chinese Sensible Code	[D4N	[D4O
QR Code	MK	PW
Maxi Code	ML	PX
PDF417	OC	PY
MicroPDF417	OD	PZ
Machine Readable Passports	[DJJ	[DJP
Machine Readable Visas-A	[DJK	[DJQ
Machine Readable Visas-B	[DJL	[DJR
Official Travel Documents 1	[DJM	[DJS
Official Travel Documents 2	[DJN	[DJT
ISBN	[DJO	[DJU

**Preamble/Postamble Commands**

Preamble/Postamble	Command
Preamble	MZ
Postamble	PS

**7.2.3 ASCII (Prefix/Suffix Values)**

ASCII	Command	ASCII	Command	ASCII	Command	ASCII	Command
<SPACE>	5A	A	0A	a	\$A	^@ (NULL)	9G
!	5B	B	0B	b	\$B	^A (SOH)	1A
"	5C	C	0C	c	\$C	^B (STX)	1B
#	5D	D	0D	d	\$D	^C (ETX)	1C
\$	5E	E	0E	e	\$E	^D (EOT)	1D
%	5F	F	0F	f	\$F	^E (ENQ)	1E
&	5G	G	0G	g	\$G	^F (ACK)	1F
'	5H	H	0H	h	\$H	^G (BEL)	1G
(	5I	I	0I	i	\$I	^H (BS)	1H
)	5J	J	0J	j	\$J	^I (HT)	1I
*	5K	K	0K	k	\$K	^J (LF)	1J
+	5L	L	0L	l	\$L	^K (VT)	1K
,	5M	M	0M	m	\$M	^L (FF)	1L
-	5N	N	0N	n	\$N	^M (CR)	1M
.	5O	O	0O	o	\$O	^N (SO)	1N
/	5P	P	0P	p	\$P	^O (SI)	1O
:	6A	Q	0Q	q	\$Q	^P (DLE)	1P
;	6B	R	0R	r	\$R	^Q (DC1)	1Q
<	6C	S	0S	s	\$S	^R (DC2)	1R
=	6D	T	0T	t	\$T	^S (DC3)	1S
>	6E	U	0U	u	\$U	^T (DC4)	1T
?	6F	V	0V	v	\$V	^U (NAK)	1U
@	6G	W	0W	w	\$W	^V (SYN)	1V
[	7A	X	0X	x	\$X	^W (ETB)	1W
\	7B	Y	0Y	y	\$Y	^X (CAN)	1X
]	7C	Z	0Z	z	\$Z	^Y (EM)	1Y
^	7D	0	Q0			^Z (SUB)	1Z
_	7E	1	Q1			^[ (ESC)	9A
`	7F	2	Q2			^\ (FS)	9B
{	9T	3	Q3			^] (GS)	9C
	9U	4	Q4			^^ (RS)	9D
}	9V	5	Q5			^_ (US)	9E
~	9W	6	Q6			DEL (ASCII127)	9F
		7	Q7				
		8	Q8				
		9	Q9				

## 7.2.4 Code ID

To add Code ID, send the appropriate command and set the prefix/suffix.

### Code ID Commands

Command	Description
\$2	Code identification using OPTICON ID
\$1	Code identification using AIM ID/ ISO 15424

Use one of these methods to add Code ID:

- Add Opticon Code ID: For help, see [“Opticon Code ID Prefix/Suffix Value”](#).
- Add AIM/ISO Code ID: For help, see [“Code Option AIM/ISO15424 Code ID Prefix/Suffix Values”](#).  
The code identifier is transmitted in ISO 15424 format:

]cm

where:

] is ASCII value, decimal 93  
 c is the code character  
 m is the modifier character

Example:

To add “<OPTICON Code ID>” to the all codes prefix, use this command:

<ESC>RY\$2<CR>

## 7.2.5 Code Length

For 1D barcodes, the code length is transmitted as two digits, excluding prefix and suffix characters. For 2D codes the code length is transmitted as 6 digits. You can also send the length as 6 digits for both 1D and 2D codes. These direct input characters count as one entry of the four permissible entries for a prefix and suffix.

Code length can be added by sending a command followed by the prefix/suffix setting command.

### Code Length Commands

Command	Description
\$3	Code length (1D/2D: 2/6 digit)
\$6	Code length (1D/2D: 6/6 digit)

Example:

To set the prefix for all codes to <Code length (1D/2D: 2/6 digit)>, use this command:

<ESC>RY\$3<CR>

### 7.2.6 Code Coordinates

The code coordinate is transmitted as the pixel coordinate of the image sensor. You can output the vertexes or the center of the code within the image.

#### Code Coordinates Commands

Command	Description
[DDX	Code vertex coordinate
[DDY	Code center coordinate

Vertexes output format:

$X_1/Y_1:X_2/Y_2:X_3/Y_3:X_4/Y_4$

Center output format:

$X/Y$

X Y format:

X: 1 to 3 digits

Y: 1 to 3 digits

The range of coordinate is illustrated in the next diagram where:

X: 0 to 639

Y: 0 to 479

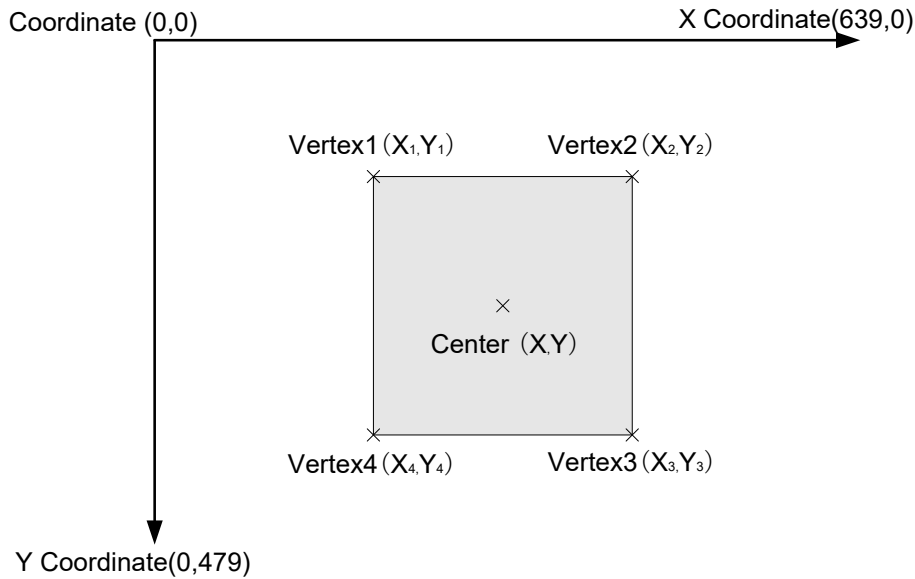

## 7.2.7 Code Tilt Angle

The tilt angle of the scanned code can be added to the scan result with the prefix/suffix.

### Code Tilt Angle Command

Command	Description
[DPS	Outputs the tilt angle of the scanned code.

Output format:

+000 to +179, -001 to -180

QR Code



Output: +000

Barcode

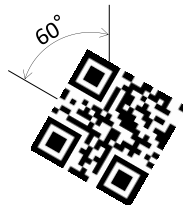

-060

Output: +000



+030



Example:

To add the angle to a common prefix, use this command:

<ESC>MZ[DPS<CR>

### 7.2.8 Scan Time

The scan time is the time from when the trigger is pressed until data output starts.

#### Scan Time Value Command

Command	Description
[EDG	Scan time

Scan time output format:

[Tms

where T is flexible length and the maximum string length is 4.

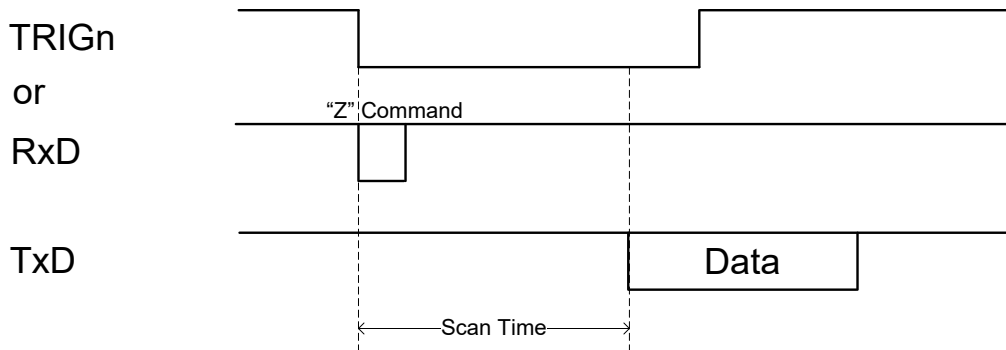

### 7.2.9 Bank Number

To output the bank number (BankIndex) currently being used, add the Bank Number command to the prefix/suffix.

#### Bank Number (BankIndex) Command

Command	Description	Default
[EDJ	Bank number currently used.	00

\* The range of the bank number is 00 (bank not registered) through 07.

Output format:

XX = 2 digit number 00 - 07

## 8 Read Options

This chapter describes the read options for the imager engine.

### 8.1 [Read Modes](#)

#### 8.2 [Manual Trigger](#)

#### 8.3 [Auto Trigger](#)

#### 8.4 [Illumination and Aiming](#)

#### 8.5 [Batch Reading / Data Edit Function](#)

#### 8.6 [Auto Exposure Control](#)

#### 8.7 [Exposure Fixation](#)

#### 8.8 [Tuning Function](#)

#### 8.9 [Bank Function](#)

#### 8.10 [Decode Area](#)

#### 8.11 [Reading Test Command](#)

#### 8.12 [Error Message](#)

## 8.1 Read Modes

Code reading starts when the trigger signal (TRIGn) is pulled low, when the trigger command (“Z”) is received, or when an object is detected while in auto trigger mode.

### 8.1.1 Read Modes

Read modes includes “single read”, “multiple read 1”, and “multiple read 2”.

#### Read Mode Commands

Read Mode	Command	Description	Default
Single Read	S0	Single read with a single trigger pull.	✓
Multiple Read 1	[D3P	Multiple read in a single trigger pull. The imager engine saves the read data in memory so it does not read the same data.	
Multiple Read 2	S1	Multiple read in a single trigger pull. The imager engine reads the same data.	
Continuous Read	S2	The imager engine produces as much data as it can decode, regardless of whether the data is the same. This mode generates heat, so it is mainly used for demonstration and diagnostic purposes.	

#### Single Read

The imager engine starts reading after a trigger pull and reads until a barcode is successfully decoded or until the read time expires. For help, see [“Read Effective Time”](#).

#### Multiple Read 1

The imager engine starts reading after a trigger pull and continues to read (even after a barcode is successfully decoded) until the read time expires. To prevent a barcode from being read twice, the imager engine saves the read barcodes in memory and checks if it has been previously read. The imager engine can hold 20 barcodes in memory. After 20 different barcodes are read, the same barcode can be read again.

If there is more than one code within the read area (see the next illustration) this read mode prevents the same code from being read twice.

Example: Continuously read multiple codes with a single trigger pull.

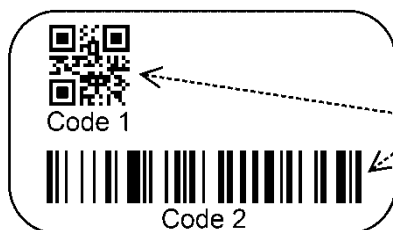

To prevent that a barcode is read twice, the imager engine saves the read barcodes in memory and checks if it has been previously read.

### Read Mode Parameters

Parameter	Command			Description	Default(Effective Range)	
Multiple Read 1 (number of codes read with unique data)	[D3P	Qa	Qb	Qc	Set the number of codes to be saved in the memory: a:100 digits/ b:10 digits / c:1 digit	Default: 20 (Effective range: 1 to 200)
Stop Reading When the Number Set is Reached	[DPE			Enable stop reading when reaches the number		
	[DPD			Disable stop reading when reaches the number	✓	

### Multiple Read 2

The imager engine starts reading after a trigger pull and continues to read (even after a barcode is successfully decoded) until the read time expires. The same barcode cannot be read twice unless another barcode is read or the Double Read Reset Time has passed. For help, see [“Double Read Reset Time”](#).

If the same code continues to be at the same position in the image, the code will not be read even if the double read reset time is canceled.

Example:

Read multiple codes sequentially with single trigger.



### 8.1.2 High-Speed Slide Read Mode

High-speed slide read mode speeds up reading by optimizing exposure adjustment and decoding when sliding multiple codes attached to trays.

#### High-Speed Slide Reading Mode Commands

Command	Description	Default
[DPA	Disable high-speed slide reading mode.	✓
[DPB	Enable high-speed slide reading mode.*	

\* Response time may be improved by limiting the codes to read. For help, see [“Setting Readable Codes”](#).

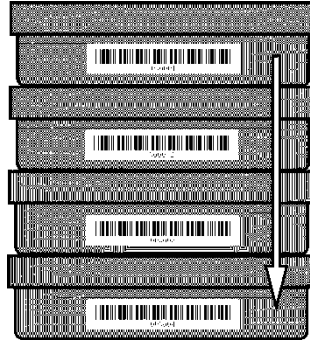

### 8.1.3 Toggle Trigger Mode

Toggle trigger mode switches the scan start and stop by the TRIGn signal. This mode reduces the load of pressing the trigger for long periods of time (for example, performing multiple reads).

#### Toggle Trigger Mode Commands

Command	Description	Default
[DPW	Disable toggle trigger	✓
[DPX	Enable toggle trigger*	

\* The toggle trigger is disabled in these settings: Single read and Trigger signal synchronization (Y0), read start mode without using trigger (S1), and Auto trigger (+1).

\* Trigger repeat is disabled when the toggle trigger is set.

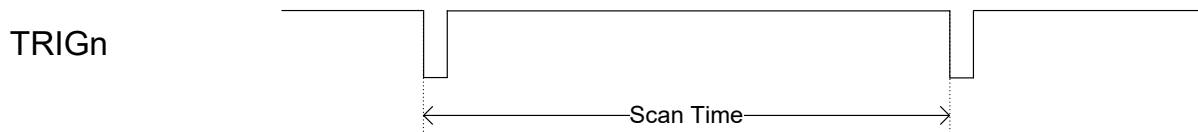

### 8.1.4 Disable Trigger (Always Read)

You can configure the imager engine to read multiple codes without a trigger signal. When this command is set, the read mode is Multiple Read 2.

#### Disable Trigger Commands

Command	Description	Default
S7	Always operate in reading mode*	
S8	Starts reading by trigger signal or software trigger	✓

\* You can change the read mode from Multiple Read 1 to Multiple Read 2.

### 8.1.5 Central Reading

This function can be used to read a specific target code when multiple codes are close to each other. Only the code in the central part of the image will be read (see the next illustration).

#### Central Reading Commands

Command	Description	Default
[D00	Enable central reading (only read a code at the center of the aiming LED)	
[D0Z	Disable central reading (read codes in the entire image)	✓

Examples of readable positions when central reading is enabled



Examples of unreadable positions when central reading is enabled



\* When several codes are tightly packed, you should use Trigger Repeat (See: 8.2.1) to improve reading performance. For help, see [“Trigger Repeat”](#).

### 8.1.6 Central Reading Range

In general, widening the central reading range makes it easier to read bar codes. Narrowing the central reading range helps reduce misreading barcodes that are close to the imager engine.

#### Central Reading Range Commands

Command	Command Description	Default
[DMQ Q0	Central reading range: Narrow	
Q1	Central reading range: Regular	✓
Q2	Central reading range: Wide	

The next illustration shows the range (grey rectangle) against the angle of view for each setting.

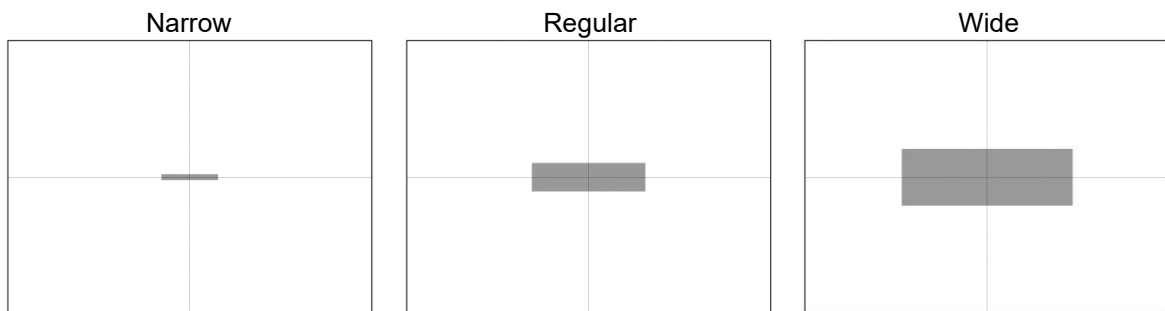

## 8.2 Manual Trigger

### 8.2.1 Trigger Repeat

Trigger repeat helps properly aim the imager engine before it starts scanning. This feature can be useful when several codes are printed close to each other.

The actual behavior depends on the configuration of Central Reading. For help, see [“Central Reading”](#).

#### Trigger Repeat Commands

Command	Description	Default
/K	Disable trigger repeat	✓
/M	Enable trigger repeat	

The operation of Trigger Repeat depends on the Read Effective Time. For help, see [“Read Effective Time”](#).

Read time options:

- Trigger key is synchronized (default).

Example:

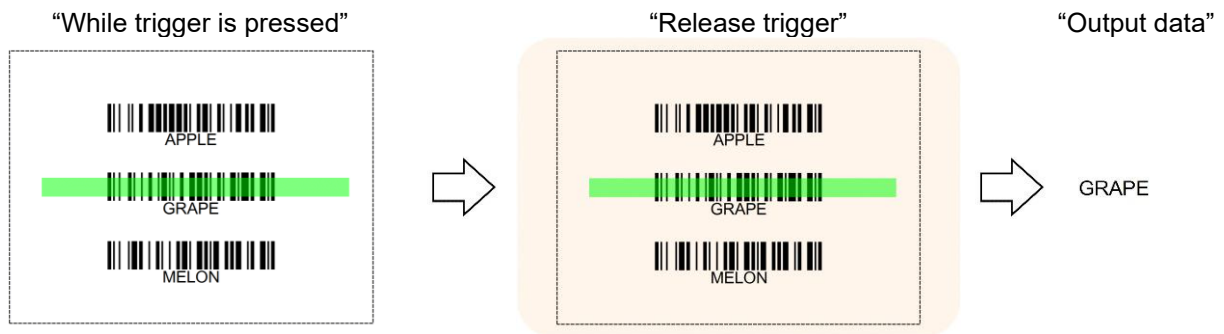

- Read time option is 1 second or more.

Example:

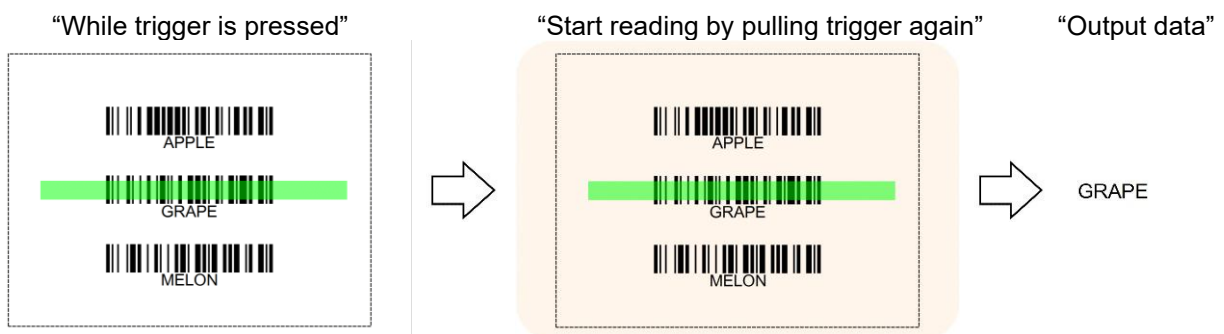

## 8.3 Auto Trigger

When auto trigger is enabled, the imager engine automatically detects a code and starts reading.

### 8.3.1 Normal Auto Trigger

Auto Trigger has two modes:

- Presentation auto trigger mode: Use this mode when the imager engine position is fixed and codes are presented to the imager engine.
- Handheld auto trigger mode: Use this mode when the imager engine position is not fixed.

#### Auto Trigger Commands

Parameter	Command	Description	Default
Auto Trigger	+F	Disable presentation auto trigger mode	✓
	+I	Enable presentation auto trigger mode	
Auto Trigger Mode	[DL5]	Presentation auto trigger mode	✓
	[DL6]	Hand held auto trigger mode	

### 8.3.2 Auto Trigger Sensitivity

To adjust to the environment, you can configure auto trigger detection sensitivity.

#### Auto Trigger Sensitivity Commands

Command	Description	Default
[XMF]	Sensitive	
[XMH]	Normal	✓
[XMJ]	Not Sensitive	

### 8.3.3 Double Read Reset Time

Double Read Reset Time sets the time interval before the same code can be decoded again in auto trigger mode. When a code with different data is read, this parameter is reset.

#### Double Read Reset Time Commands

Command					Description	Default(Valid Range)
[D3R	Qa	Qb	Qc	Qd	Double read reset time (1000a+100b+10c+d) [10ms]	700 ms (0 - 9999)

\* When set to 0 seconds, the same code will not be decoded.

### 8.3.4 Read Time Adjustment

Read Time Adjustment sets the time to end auto trigger scanning.

#### Auto Trigger Read Time Adjustment Commands

Command	Description	Default
[EFH]	Long time	
[EFI]	Normal	✓
[EFJ]	Short time	

\* Use this parameter with Read Effective Time. For help, see "[Read Effective Time](#)".

### 8.3.5 Auto Trigger Sleep Transition Time

In auto trigger mode, if the imager engine does not detect a barcode after a specific configurable period of time, the imager engine goes into sleep mode. In sleep mode, the imager engine performs presence detection at specified time intervals. When a target barcode is detected or if an event such as trigger occurs, the imager engine exits sleep mode. Sleep mode is disabled when the time is set to 0 seconds.

#### Auto Trigger Sleep Transition Time Commands

Command					Description	Default(Valid Range)
[EBW	Qa	Qb	Qc	Qd	Transition time to sleep mode (1000a+100b+10c+d) [s]	5 s (0 - 9999)

### 8.3.6 Detection Mode

There are three methods for detecting a target code:

- Warm white illumination detection: When a target code falls within the range of the field of view of the warm white light, the target is detected. This mode is preferred in a dark environment.
- Green aiming detection: When a target code falls within the green aiming light, the target is detected. This mode is recommended for indoor use only, because target detection is reduced in environments with higher illumination levels than typically found indoors.
- No illumination detection: A target code is detected without illumination light. Power consumption is reduced, but the effectiveness of detection will also be reduced. In this mode, ambient light is used for detection, so this mode is most effective in a well-lit area and should not be used in a dark environment.

#### Auto Trigger Commands

Command	Description	Default
[DDG]	Green aiming detection	✓
[DDH]	Warm white illumination detection	
[DDI]	No illumination detection	

## 8.4 Illumination and Aiming

You can enable or disable warm white illumination for reading and green LED for aiming.

### 8.4.1 Reading LED Illumination

You can set the illumination method and brightness for reading:

- LED Illumination: Enable/Disable  
When illumination is disabled, reading performance may be degraded. But, when reading only the code displayed on the LCD screen, reading performance may improve.
- LED Illumination: Automatic switching  
Illumination automatically switches between floodlight ON and OFF. The illumination mode selected when a code was read is memorized and prioritized for subsequent reading. Use this setting when reading a target with specular reflection.
- LED Illumination: Prevent specular reflection  
Disable illumination only when specular reflection occurs.

#### LED Illumination Mode Commands

Command	Description	Default
[D39	LED illumination: Enable	
[D3A	LED illumination: Disable	
[D3B	LED illumination: Automatic switching	
[D3Q	LED illumination: Prevent specular reflection	✓

You can set these commands to prevent flickering:

- Prevent flickering: LED illumination flicker prevention  
Does not prioritize code reading performance on dark screens to prevent flicker.
- Prevent flickering: Give priority to LCD display reading.  
Prioritizes code reading performance on dark screens, causing flicker in LED illumination.

#### Prevent Flickering Commands

Command	Description	Default
[D3I	LED illumination flicker prevention.	✓
[D3J	Give priority to LCD display reading.	

You can set these commands to adjust brightness:

- LED Illumination brightness: Standard brightness  
Standard LED illumination control mode.
- LED Illumination brightness: Minimum brightness  
Provides minimum illumination brightness required for reading. Motion tolerance performance will be degraded. Use this setting for a built-in system when the LED illumination area faces the operator.

#### LED Illumination Brightness Adjustment Commands

Command	Description	Default
[DPV	LED brightness: Standard brightness	✓
[DPU	LED brightness: Minimum brightness	

### 8.4.2 External LED Illumination

In some environments, external LED illumination may be necessary. The imager engine can provide an output signal on Pin-3.

To activate and save the new configuration, you need to use the Z2 command (save settings in non-volatile memory).

#### LED Output Mode Commands

Command	Description	Default
[D26	Disable external LED illumination signal. (enables Good Read Output Signal)	✓
[D28	Enable external LED illumination signal. (disables Good Read Output Signal)	

### 8.4.3 LED Aiming

Green LED floodlight used for aiming can be set to enable/disable. The brightness is also configurable.

#### LED Aiming Commands

Parameter	Command	Description	Default
LED Aiming ON/OFF	[D3D	Enable LED aiming	✓
	[D3E	Disable LED aiming	
LED Aiming Brightness	[DDD	Brightness "High"	✓
	[DDE	Brightness "Standard"	
	[DDF	Brightness "Low"	

## 8.5 Batch Reading/Data Edit Function

### 8.5.1 Batch Reading

When reading fixed format code in a batch, you can use UniversalConfig to configure the batch reading function.

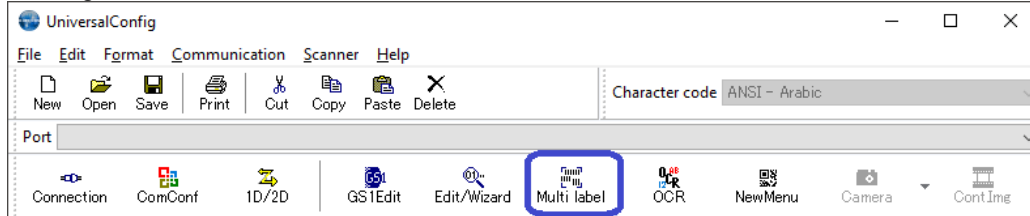

You can set up to 6 codes.

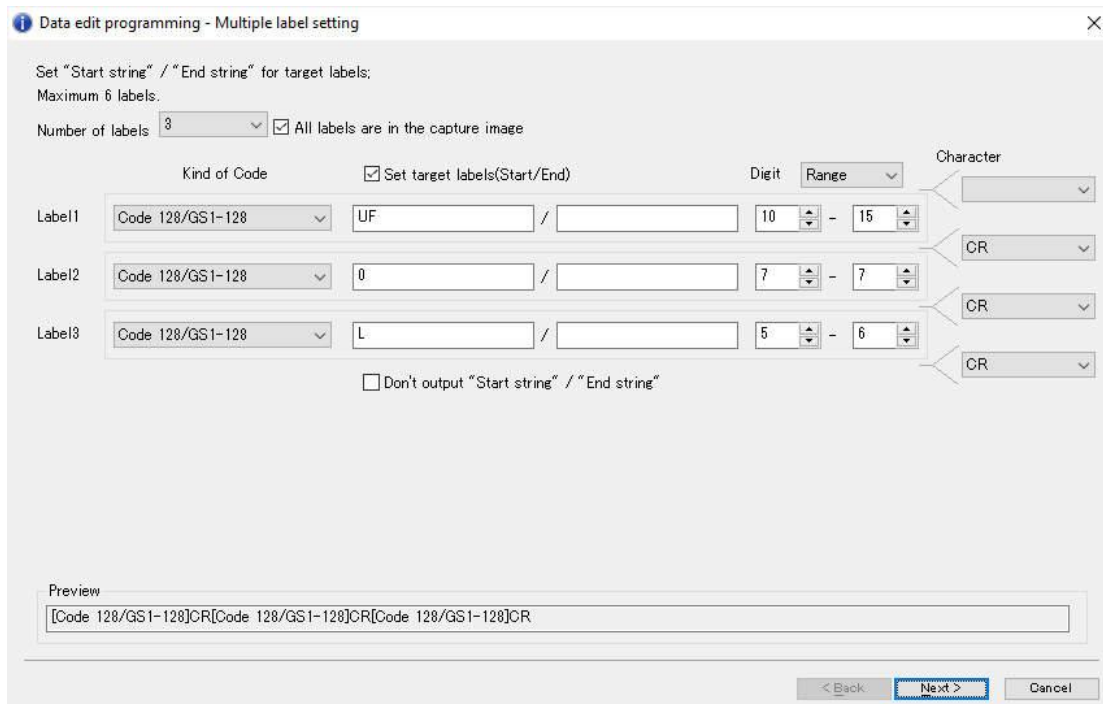

Sample multi label chart



\* For options that cannot be set, contact your local sales office.

## 8.5.2 Data Edit Reading

The typical data edit/wizard of data editing functions are installed as the Output Edit Function in Opticon's UniversalConfig 2.10 or later version.

For settings that cannot be completed with the Output Edit Function, contact your local sales office.

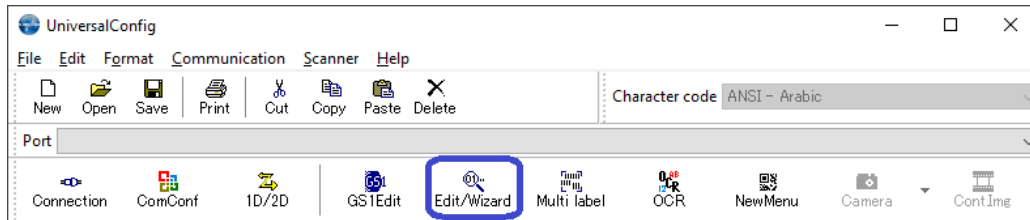

These types of data output editing are available:

- Cut out
- Zero padding or deletion
- Character conversion
- Character deletion

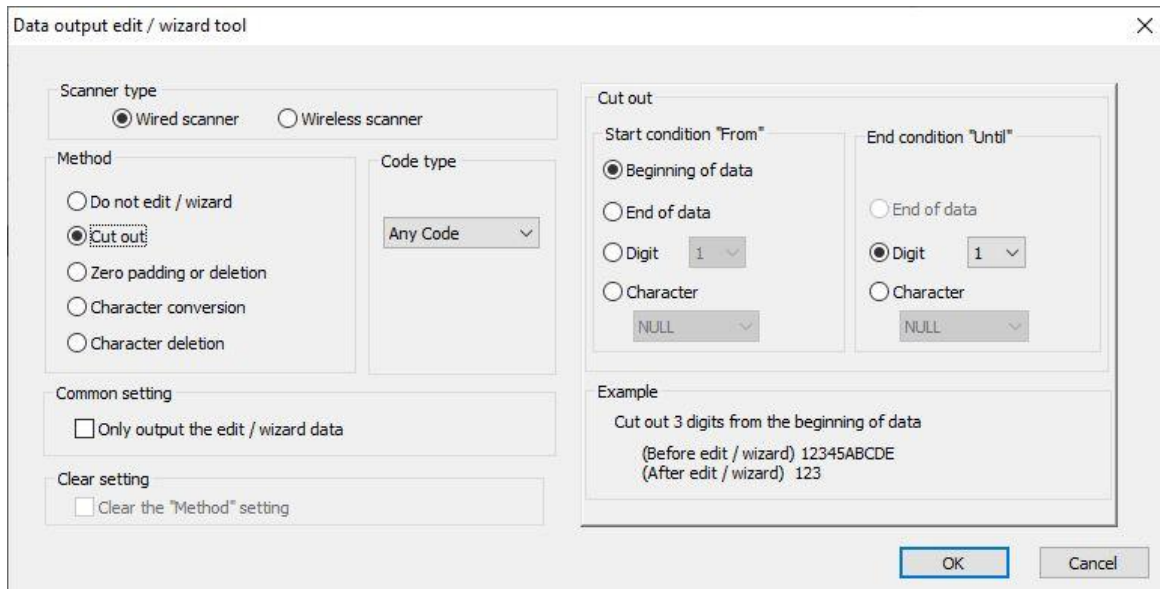

### 8.6 Auto Exposure Control

The initial auto exposure control setting for the imager engine is to adjust the center of the image to a target brightness of 480/1023 gradations.

#### 8.6.1 Target Brightness

By setting the target brightness, you can improve reading of low contrast codes. For example, setting the target brightness value to 750 creates a stable environment to read low PCS or codes with a colored background.

#### Target Brightness Commands

Parameter	Command					Description	Default
Target brightness of exposure control	[DS1					Disable target brightness	✓
	[DS2					Enable target brightness value	
Target brightness value	[DS3	Qa	Qb	Qc	Qd	Value = (1000a+100b+10c+1d) Setting range: 0000 to 1023	480
Upper limit of brightness value*	[DS4	Qa	Qb	Qc	Qd	Value = (1000a+100b+10c+1d) Setting range: 0000 to 1023	576
Lower limit of brightness value*	[DS5	Qa	Qb	Qc	Qd	Value = (1000a+100b+10c+1d) Setting range: 0000 to 1023	400

\* Must be set within these ranges:

Upper limit of brightness value > Target brightness value x 1.2

Lower limit of brightness value < Target brightness value/1.2

Example: To set target brightness to 750, upper limit to 900, and lower limit to 625, send this command:

[DS3Q0Q7Q5Q0][DS4Q0Q9Q0Q0][DS5Q0Q6Q2Q5

Use Opticon's UniversalConfig to configure settings while checking the image.

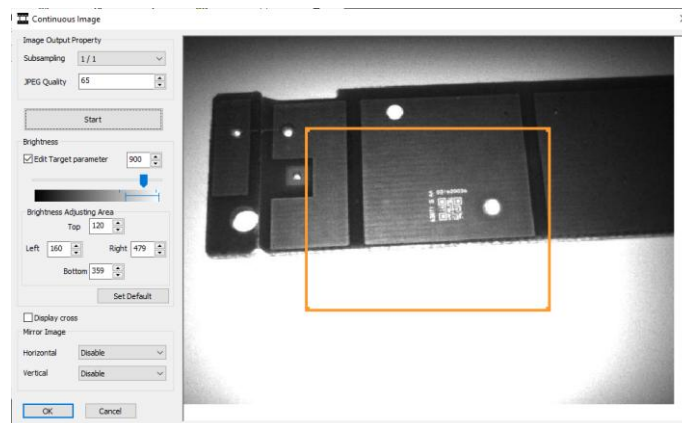
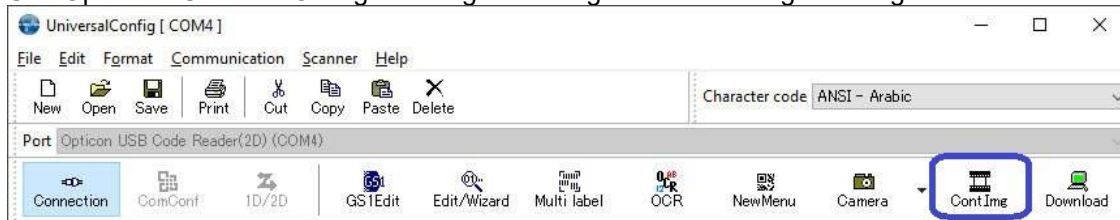

### 8.6.2 Exposure Control Area

When the imager engine is installed in an embedded device, the problem can be solved by moving the exposure control area, when the area is made of a material such as metal that causes specular reflection, or when there is no background and adjustment is impossible.

Use Opticon's UniversalConfig to configure settings while checking the image.

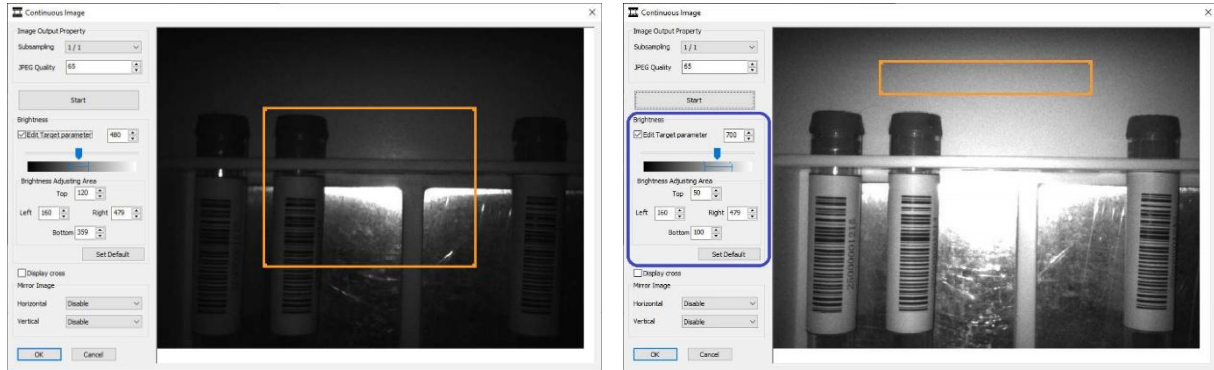

The auto exposure control area is set by inputting the coordinates of the two points using a 4-digit number.

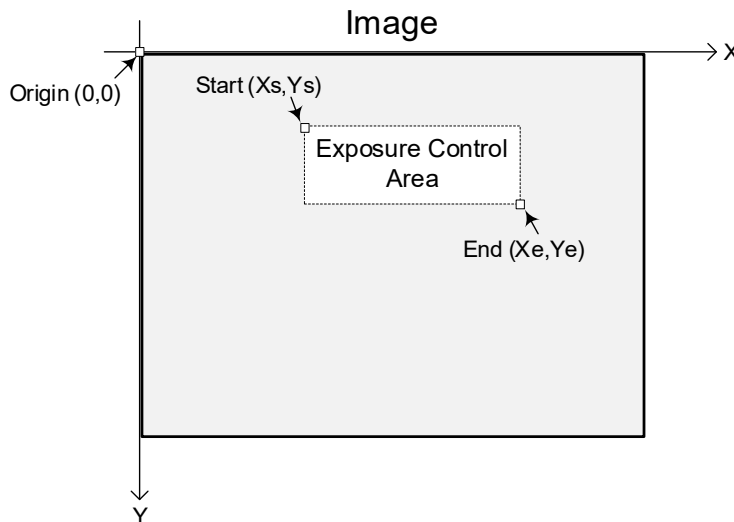

#### Exposure Control Area Commands

Parameter	Command				Description	Default	
Coordinates of Xs	[DMA	Qa	Qb	Qc	Qd	Value = (1000a+100b+10c+1d)	160
Coordinates of Ys	[DMB					X range: 0000 to 0639	120
Coordinates of Xe	[DMC					Y range: 0000 to 0479	479
Coordinates of Ye	[DMD						359
Exposure Control Area	[DME					Enable *	
	[DMF					Disable	✓

\* Exposure Control Area works with the coordinates of the original image. For help, see "[Image Settings](#)".

## 8.7 Exposure Fixation

Exposure Fixation lets you set the two factors that determine exposure: exposure time and gain of the sensor sensitivity (amplification factor). By default, the imager engine evaluates the brightness of the image and automatically adjusts the exposure. You can use Exposure Fixation to set the optimal exposure for a specific reading condition.

**Note:** When applying exposure fixation to multiple scanners, note that exposure varies by device. Carefully evaluate the setting on your device.

### 8.7.1 Fixing the Exposure Time

#### Fix Exposure Time Commands

Parameter	Command					Description	Default	Bank
Fix Exposure Time	[D23	Qa	Qb	Qc	Qd	Exposure time values: (1000a+100b+10c+1d) x [10μs] Setting range: 30 ~ 99990μs	-	Enable
Adjust Exposure Time Automatically	[D24					Enable automatic adjustment of the exposure adjustment time.	✓	

Example:

To set exposure time to 1400μs (1.4 ms), send this command:

[D23Q0Q1Q4Q0

### 8.7.2 Fixing the Sensor Gain (Amplification Factor)

#### Fix Sensor Gain Commands

Parameter	Command					Description	Default	Bank
Fix sensor gain	[E70	Qa	Qb	Qc	Qd	Set the sensor gain by following value: Sensor gain=ab.cd times(x100%) Setting range: x1.00 ~ x15.93	-	Enable
Adjust sensor gain automatically	[E71					Enable automatic adjustment of the sensor gain	✓	

Example:

To set the sensor gain to 8.5 times, send this command:

[E70Q0Q8Q5Q0

### 8.7.3 Confirm the Fixed Status of Exposure Time and Sensor Gain

#### Confirm Fixed Status of Exposure Time Commands

Command		Response	Description	Default	Bank
[XUL	Q1	Q0	OK<CR>, NG<CR>	OK = Fixed NG = Auto	NG
		Q2	OK<CR>, NG<CR>	OK = Fixed NG = Auto	

### 8.7.4 Confirm the Fixed Values of the Exposure Time and Sensor Gain

#### Confirm the Fixed Values of Exposure Time and Sensor Gain Commands

Parameter	Command		Response	Description	Default	Bank
Confirm the Fixed Values of the Exposure Time	[XUL	Q0	OK,nnnn<CR>	nnnn x0.01[ms]	nnnn=0000 (Auto exposure)	Enable
Confirm the Fixed Values of the Sensor Gain		Q2	OK,nnnn<CR>	nnnn x0.01[times]	nnnn=0100 (Including auto exposure)	

## 8.8 Tuning Function

### 8.8.1 Tuning Function Overview

The tuning function limits the code to be read by adjusting the imager engine to the best exposure to achieve optimal stable reading in a stationary position. By adjusting the exposure range, you can improve the performance of scan-in-motion applications.

To configure the tuning function, use Opticon’s “UniversalTuningTool” to determine the optimal installation conditions.



To order the “UniversalTuningTool,” contact your local sales office.

**UniversalTuningTool** Version 2.0.1

Port: COM4

**Bank 1**  
Code : QRCode  
Exposure : Fix

**Bank 2**  
Code : EAN  
Exposure : Fix

**Bank 3**  
Code :  
Exposure : Auto

**Bank 4**  
Code :  
Exposure : Auto

**Bank 5**  
Code :  
Exposure : Auto

**Bank 6**  
Code :  
Exposure : Auto

**Bank 7**  
Code :  
Exposure : Auto

**Image View**  
View DecodeArea

480px  
26ms  
640px

**Tuning Option**  
Fix Motion  
DPM Filter  
Illumination  
Decode Area

**Read Test**

No.	Read Rate	Read Time
6	80%	26 - 26ms
5	90%	21 - 26ms
4	100%	21 - 27ms
3	80%	21 - 26ms
2	90%	22 - 27ms
1	80%	21 - 27ms
0	80%	21 - 27ms

**Tuning**

Sharpness: 13 to 43  
Brightness: 378 : 128 to 1490 : 240  
Shutter speed : Gain

Code Type: QRCode  
Gain: 227%  
Shutter Speed: 1368us  
Read Rate: 90%  
Read Time: 21 - 27ms  
Negative(1D Code): ---  
Decode timeout: Auto

Tuning Start

Test Start

## 8.8.2 Tuning Setting Flow

To configure Tuning Setting Flow, you need to perform “Examination” and “Integration.”

<b>Examination</b>	
Examine installation requirements and confirm operable condition.	
Determine the imager engine focus model by code resolution and installation distance. ↓	See “ <a href="#">MDI-4600/MDI-4700 Specification Overview</a> ”.
Examine optimum installation condition (for example, without reflection) using UniversalTuningTool. ↓	
Perform tuning. ↓	See “ <a href="#">Execute Tuning</a> ”.
Perform a test and confirm whether reading is stable. ↓	
See the “require setting for operation”.	Refer to the appropriate section.

<b>Integration</b>	
Set the imager engine in the following order.	
Configure settings that are required in advance, like interface settings. ↓	See “ <a href="#">Interface Options</a> ”.
Configure “require setting for operation”. ↓	Refer to the appropriate section.
Perform tuning.* <sup>1</sup> ↓	See “ <a href="#">Execute Tuning</a> ”.
Set additional codes, if necessary.*	See “ <a href="#">Setting of Readable Codes</a> ”.

<sup>\*1</sup> **Caution:** Tuning adjustment value differs for each imager engine. So, you should perform tuning for each imager engine.

<sup>\*2</sup> When setting an additional code, the code needs to be at the same distance and reflectance.

### 8.8.3 Execute Tuning

Execute Tuning by sending a command.

#### Execute Tuning Commands

Command	Description	Notes
[DT1	Start tuning.	*1
[DT2	Stop tuning.	*2

\*1 "Tuning complete" will be output when tuning is successful. After a line break, each output item when tuning is separated by ":".

Tuning complete<CR>							
Indicate tuning success and line brake.							
BANK 1:CODETYPE QRCode:SHUTTER 177[us]:GAIN 648[%]:RATE 100[%]:TIME 25 - 26[ms]:123456789<CR>							
Bank No.	Code Type	Shutter Speed	Sensor Gain	Read rate in 10 times	Min/Max of read times in 10 times	Read Data	Line Break

\*2 The output when tuning failed or stopped.

Tuning failed<CR>							
Indicate tuning failed or stopped and line break.							

### 8.8.4 Motion Tolerance Setting (Setting the Exposure Adjustment Range of Tuning)

Tuning adjusts “Shutter time” and “Sensor Gain”. The range can be set in advance when adjusting. By adjusting the range, the following effects can be obtained. To Support motion tolerance tuning, shorten the adjustment upper limit time of the shutter time. Reducing the adjustment upper limit value of the sensor gain may reduce noise and make it easier for the imager engine to read.

#### Exposure Adjustment Range Setting Commands

Command							Description	Notes
[DT3	Qa	Qb	Qc	Qd	Qe	Qf	Set lower/upper limit value of “Shutter time” and “Sensor gain” at tuning.	*1

\*1 For “a/b/c/d/e/f”, set by the following parameter.

#### Shutter Time and Sensor Gain Parameters

Parameter	a	b	c def	Adjustment range
Shutter time: Adjustment lower limit value [μs]	0	0	Set to d.ef x 10 <sup>c</sup> [μs]	From 30μs
Shutter time: Adjustment upper limit value [μs]	0	1		To 9000μs
Sensor gain: Adjustment lower limit value [times]	1	0	Set to cd.ef [times]	From 1 time
Sensor gain Adjustment upper limit value [times]	1	1		To 10 times

Example:

To set adjustment upper limit value of shutter time to 400 μs, send this command:

<ESC>[DT3Q0Q1Q2Q4Q0Q0<CR>

#### Output Exposure Adjustment Range Commands

Command	Description	Notes
[DT4	Outputs lower/upper limit value of “Shutter time” and “Sensor gain” at tuning.	*2

\*2 The output of exposure adjustment range are as follows.

Shutter speed 100 - 400[us] <CR>
Indicate adjustment of shutter time and line break.
Gain 100 - 1000[%]<CR>
Indicate adjustment of sensor gain and line break.

#### Reset Exposure Adjustment Range

Command	Description
[DT5	Reset the exposure adjustment range of the current bank to the initial setting.

## 8.9 Bank Function

Use the bank function to register various setting parameters to bank No.1 - 7 (default: No. 0). You can register the bank based on the operation.

These types of parameters can register to the bank:

- Tuning value
- Read code settings
- String options

These types of parameters cannot register to the bank:

- Interface settings
- Read operation settings

### 8.9.1 Bank Selection

#### Bank Selection Commands

Command			Description	Default
[BRA	Qa	Qb	Select bank ab Effective value: a=0, b=1-7	a=0, b=1

\* To register settings for each bank, send the bank selection command after the bank corresponding setting command.

\*\* The last bank No. sent in the command string becomes the bank No. for the next operation.

Examples:

To Set QR limited, exposure setting (exposure time: 350 μs, sensor gain: 7.00 times) to bank 1, and set Code 12 limited, exposure setting (exposure time: 400 μs, sensor gain: 8.50 times) to bank 2, send this command:

```
[BRAQ0Q1[BC1[D23Q0Q0Q3Q5[E70Q0Q7Q0Q0[BRAQ0Q2A6[D23Q0Q0Q4Q0[E70Q0Q8Q5Q0
```

**Note:** For more information about configuring exposure, see "[Tuning Function](#)".

To set QR limited, decode area left half of the image (320 x 480) to bank 1, and set QR limited, decode area right half of the image (320 x 480) to bank 2, send this command:

```
[BRAQ0Q1[BC1[DF8Q0Q0Q0Q0Q0[DF8Q1Q0Q3Q2Q0[DF8Q2Q0Q0Q0Q0[DF8Q3Q0Q0Q0Q0[BRAQ0Q2[BC1[DF8Q0Q0Q0Q0Q0[DF8Q1Q0Q0Q0Q0[DF8Q2Q0Q0Q0Q0[DF8Q3Q0Q3Q2Q0
```

**Note:** For more information about configuring decode area, see "[Decode Area](#)".

### 8.9.2 Bank Specify Trigger

The bank specify trigger operates as a combination of bank selection and the trigger "Z" command, which allows execution with one command.

#### Bank Specify Trigger Commands

Command			Description	Default
[TRG	Qa	Qb	Bank specify trigger* Effective value: a=0, b=1-7	a=0, b=1

\* To end reading, use the "Y" command like the "Z" command.

### 8.9.3 Confirm Current Bank

#### Confirm Current Bank Commands

Command	Description	Notes
[DGQ	Display the current bank with 2 digits (00-07).	*

\* When in default state with the bank initialized, "00" as the bank default will be displayed.

### 8.9.4 Initialize Bank

#### Initialize Bank Commands

Command	Description	Notes
[BRB Qa Qb	Initialize bank ab setting parameter Effective value: a=0, b=1-7	*
[BRC	Initialize all banks setting parameter.	*

\* Settings that are not included in the bank parameters will not be initialized.

\* When the bank is initialized, the imager engine operates with the default bank as long as the bank with an effective parameter is not selected.

### 8.9.5 Bank Switching

Bank Switching switches the registered banks. Reading is performed by retrying the number of retries for each bank. One read ends with the decoding timeout period. The starting bank can also be configured.

#### Bank Switching Commands

Command	Description	Default
[DED Q0 Q0 Q0 Q0 Q0	Disable bank switching.	✓
Q4 Q0 Q0 Q0 Q0	Enable bank switching.*	

\* To start reading, use the Trigger command. For help, see "[Trigger Command](#)".

#### Bank Retry Count Commands

Command	Description	Notes
[DED Q1 Qa Qb Qc Qd	The number of retries for the current bank. (1000a+100b+10c+d)[times] Valid values: 0001~9999	*

\* One scan to retry is performed for the decode timeout period. For help, see "[Decode Timeout](#)".

\* Configured after the bank selection command [BRAQ0Qx. For help, see "[Bank Selection](#)".

#### Starting Bank Commands

Command	Description	Default
[DED Q2 Qa Qb Qc Qd	Bank number at the start. (1000a+100b+10c+d) Valid values: 0001~0007	1

Example:

When bank 1 and bank 2 are tuned, starting bank is bank 2.

→ Try to scan bank 2 x 5 times with decoding timeout 100ms → Try to scan bank 1 x 2 times with decoding timeout 200ms → Loop from bank 2.

Command:

```
[DEDQ4Q0Q0Q0Q0[DFDQ2Q0Q0Q0Q2[BRAQ0Q2[DFDQ1Q0Q0Q0Q[EAVQ7Q4Q0Q1Q0Q0[BRAQ0Q1[DFDQ1Q0Q0Q0Q2 [EAVQ7Q4Q0Q2Q0Q0
```

## 8.10 Decode Area

You can configure the readable range by setting the image pixel range with a top, bottom, left, and right margin. The decode area setting is used to disable the scanning areas you do not want to scan or to limit the scanning area to improve scanning speed.

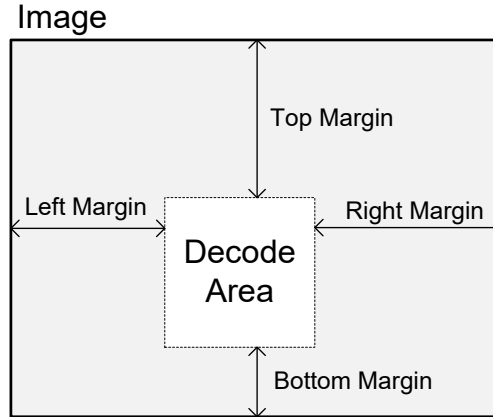

To set the decode area, input each direction margin with 4 numbers.

### Decode Area Commands

Command						Function	Description	Bank
[DF8	Qa	Qb	Qc	Qd	Qe			Enable
	a					Setting Item	0: Top margin 1: Right margin 2: Bottom margin 3: Left margin 4: Initialize all directions	
		b	c	d	e	Numeric Setting	Enter a value for each direction margin in 4-digits *The sensor image is b=0 Top and bottom margin range: 0 – 479 Left and right margin range: 0 – 639 4: When setting initializing for all directions, enter 0 for all	

**Example:**

To set the decode area to top margin: 100, right margin: 70, bottom margin: 25, and left margin: 125, send this command:

```
[DF8Q0Q0Q1Q0Q0Q][DF8Q1Q0Q0Q7Q0][DF8Q2Q0Q0Q2Q5][DF8Q3Q0Q1Q2Q5
```

To initialize the decode area, send this command:

```
[DF8Q4Q0Q0Q0Q0
```

**Note:** You can also set this command with Opticon's UniversalTuningTool.

The screenshot displays the UniversalTuningTool interface with the following sections:

- Top Bar:** Version 2.0.1, Help, Tune, Bank, Configure, Utility.
- Left Panel (Bank Settings):**
  - Bank 1: Code: Code128, Exposure: Fix
  - Bank 2: Code: , Exposure: Auto
  - Bank 3: Code: , Exposure: Auto
  - Bank 4: Code: , Exposure: Auto
  - Bank 5: Code: , Exposure: Auto
  - Bank 6: Code: , Exposure: Auto
  - Bank 7: Code: , Exposure: Auto
- Image View guidelines:** Shows a camera view of three barcode tubes. A red dashed box highlights a barcode with the text "181 640px" and "25000001214". A vertical red dashed line is also present.
- View DecodeArea:** A checkbox that is checked.
- Mode:** Decode Capture (selected), Continuous Shot.
- Number of Shot:** Low/High Speed (selected).
- Quality:** Aiming On (selected).
- Buttons:** Capture Start.
- Tuning Option:**
  - Port: COM4
  - Return Port Select
  - Decode Area: 160 (Horizon), 640 (Vertical)
  - Buttons: Cancel, OK
- Tuning:**
  - Graph: Sharpness vs. Brightness / Shutter speed : Gain. The graph shows a peak at 1361 : 226.
  - Code Type: Code128
  - Gain: 226%
  - Shutter Speed: 1361us
  - Read Rate: 100%
  - Read Time: 20 - 22ms
  - Negative(1D Code): Disable
  - Decode timeout: Auto
  - Button: Tuning Start
- Read Test:**
  - Table with columns: No., Read Rate, Read Time.
  - Button: Test Start

## 8.11 Reading Test Command

After tuning, use a test command to confirm that the integration condition and tuning work properly. The reading test outputs one result after reading 10 times for each image. Output is continuous.

### Reading Test Start/End Commands

Command	Description
.V	Start reading test.
.W	End reading test.

The reading test continuously outputs this data.

BANK 1:RATE 100[%]:TIME 25 - 26[ms]:123456789<CR>				
BANK 1:RATE 100[%]:TIME 24 - 28[ms]:123456789<CR>				
BANK 1:RATE 100[%]:TIME 24 - 27[ms]:123456789<CR>				
BANK 1:RATE 100[%]:TIME 24 - 26[ms]:123456789<CR>				
Bank No.	Read rate in 10 times	Max/Min read time in 10 times	Read data	Line break

## 8.12 Error Message

The imager engine can send an error message when a code is not read during scanning and is stopped due to a stop condition such as read time expires etc.

### Error Message Setting Commands

Command		Description
	Available characters	Set the error message with specified characters.
TH* <sup>1</sup>	ASCII* <sup>2</sup>	
	0 to 8 characters	

\*<sup>1</sup> To clear the error message, only set TH.

\*<sup>2</sup> NULL cannot be set.

Examples:

To set the error message to "NG", send this command:

```
TH0N0G
```

To set the error message to "ERROR<CR>", send this command:

```
TH0E0R0R0O0R1M
```

The common prefix/common suffix set in the read data will also be added to the error message, which allows the header/terminator of the read data and error message to be the same.

### Apply Common Prefix/Common Suffix Commands

Command		Description	Default
[EHM	Q0	Do not add common prefix/common suffix to the error message	✓
	Q1	Add common prefix/common suffix to the error message	

Example:

```
<STX>Read data<ETX>
```

```
<STX>Error message<ETX> (Error message"ERROR")
```

```
Command: RYZMZ1BPS1C[EHMQ1Q1TH0E0R0R0O0R
```

## **9 Indicator Options**

This chapter describes the options for Buzzer and Good Read LED.

### **9.1 [Buzzer \(BUZZERn Signal\)](#)**

#### **9.2 [Good Read LED \(GR\\_LEDn Signal\)](#)**

#### **9.3 [Good Read Aiming](#)**

#### **9.4 [Common Indicator Settings](#)**

## 9.1 Buzzer (BUZZERn Signal)

BUZZERn controls the buzzer tone and sound pressure with PWN signal.

### 9.1.1 Buzzer Loudness

The buzzer loudness is applied to all buzzers.

#### Buzzer Loudness Commands

Command	Description	Default
T0	Buzzer loudness: Maximum	✓
T1	Buzzer loudness: Loud	
T2	Buzzer loudness: Normal	
T3	Buzzer loudness: Minimum	

### 9.1.2 Good Read Buzzer

The good read buzzer is activated when a code is successfully read. You can configure three tones and five durations. You can also disable the good read buzzer.

#### Buzzer Disable/Enable Commands

Command	Description	Default
W0	Disable buzzer	
W8	Enable buzzer	✓

#### Buzzer Duration Commands

Command	Description	Default
W7	Buzzer duration: 50 ms	✓
[EFW	Buzzer duration: 75 ms	
W4	Buzzer duration: 100 ms	
W5	Buzzer duration: 200 ms	
W6	Buzzer duration: 400 ms	

#### Buzzer Tone Commands

Command	Description	Default
W1	Middle frequency buzzer (3000Hz)	3000 Hz
W2	Two-step buzzer tone (high - low buzzer)	
W3	Two-step buzzer tone (low – high buzzer)	

\* The good read buzzer tone (frequency) can be set with numerical parameters by inputting the command followed by a 4-digit numerical command.

#### Buzzer Tone Frequency Setting Commands

Command					Description	Default
[DF0	Qa	Qb	Qc	Qd	Numerical setting of buzzer tone frequency (1000a+100b+10c+d)[Hz]	3000 Hz (1 - 9999)

### 9.1.3 Start-Up Buzzer

This setting determines whether the imager engine emits a beep when it is powered on. To activate and save the new configuration, you need to use the Z2 command (save settings in non-volatile memory).

#### Startup Buzzer Commands

Command	Description	Default
GD	Disable startup buzzer	✓
GC	Enable startup buzzer	

### 9.1.4 Read Timeout Buzzer

If a code is not read within the timeout period, an error buzzer sounds when the read operation ends.

#### Read Timeout Buzzer Commands

Command	Description	Default
[EAP	Disable read timeout buzzer	✓
[EAQ	Enable read timeout buzzer	

### 9.1.5 Intermediate Buzzer

When one code is decoded, an intermediate buzzer sounds to indicate that the code is decoded but it has not yet meet the conditions to output data.

For example: Five-codes reading is set in buffer mode. The intermediate buzzer sounds after decoding the 1st, 2nd, 3<sup>rd</sup>, and 4th code. The good read buzzer sounds when the last code is decoded and the data is output. The data is not output when the 1st to 4th codes are decoded, but reading of each code can be confirmed by the intermediate buzzer. When the good read buzzer is disabled, this setting is forcibly disabled.

#### Intermediate Buzzer Commands

Command	Description	Default
[EBY Q0	Disable intermediate buzzer	
Q1	Enable intermediate buzzer	✓

\* Intermediate buzzer frequency: 5000 Hz (5 KHz), duration: 10 ms

### 9.1.6 Idle Level of BUZZERn Pin

You can configure the idle level of the BUZZERn pin so the buzzer electronics do not draw current when the buzzer is not active. For example, when a PNP transistor is used to drive the buzzer, the transistor is 'open' when the BUZZERn signal is low. So, the idle level should be low.

Configure this command as a Custom Command Line command so that it becomes the default setting. For help, see [“Custom Command Line Settings \(Change the Factory Default Settings\)”](#).

#### BUZZERn Idle Level Commands

Command	Description	Default	Notes
[BAW	Idle level low (Active high)		Enable only With “Z2”
[BAX	Idle level high (Active low)	✓	

To load the BUZZER idle level, send the Z2 command (save settings in non-volatile memory) so the settings are loaded after a power up.

## 9.2 Good Read LED (GR\_LEDn Signal)

This section assumes that an LED is connected to the GR\_LEDn pin. In most instances, a transistor is required due to the limited output current that the imager engine can supply through this pin.

### 9.2.1 Good Read LED

The good read LED lights up after a code is successfully decoded. You can disable the good read LED or configure its duration.

#### Good Read LED Commands

Command	Description	Default
T4	Disable indicator	
[XTH	Indicator duration: 60 ms	
[XT8	Indicator duration: 100 ms	
T5	Indicator duration: 200 ms	✓
T6	Indicator duration: 400 ms	
T7	Indicator duration: 800 ms	

### 9.2.2 Inversion of Good Read LED

When “Good Read LED Inversed mode” is enabled, the GR\_LEDn signal is inverted.

#### Inversion of Good Read LED Commands

Command	Description	Default
[E6Y	Good Read LED normal mode	✓
[E6Z	Good Read LED inverted mode	

## 9.3 Good Read Aiming

The green aiming light turns on after a code is successfully read or after a read timeout.

For Aiming Indicator Frequency, you can configure indicator durations after reading and indicator timing.

### Good Read Aiming Commands

Command				Function	Description	Default
[EF3	Qa	Qb	Qc			
	a			Setting items	0: Indicator frequency 1: First indicator duration after reading 5: Indicator timing	
		b	c	Numerical setting 10b + c	a=0; 00 – 99 times a=1: 00 - 99 [x10ms] a=5: 00 → reading success 01 → reading timeout	a=0:0times a=1:50ms a=5:reading success

Examples:

To configure the lights to aim two times when reading is successful, send this command:  
[EF3Q0Q0Q2[EF3Q5Q0Q0

To configure the lights to aim two times when reading times out, set the indicator frequency and send this command:  
[EF3Q0Q0Q2[EF3Q5Q0Q1

## 9.4 Common Indicator Settings

---

This setting is common to the buzzer and good read LED.

### 9.4.1 Indicator Timing

The indicators can be activated after decoding a code and before or after transmitting the data.

#### Indicator Timing Commands

Command	Description	Default	Notes
VY	Before data transmission	✓	soon after decoding
VZ	After data transmission		

## 10 Appendix

This chapter lists the reference data.

### 10.1 [Code ID Table](#)

#### 10.2 [MDI-4600 and 4700 Specification Overview](#)

#### 10.3 [Sample Codes](#)

#### 10.4 [Imager Engine software Information](#)

## 10.1 Code ID Table

These tables list the Code IDs to be added to the prefix/suffix.

### 10.1.1 Opticon Code ID Prefix/Suffix Value

Code	Code ID	Symbology	Code ID
UPC-A	C	Code 128	T
UPC-A +2	F	GS1-128	
UPC-A +5	G	GS1 DataBar	y
UPC-E	D	CC-A	m
UPC-E +2	H	CC-B	n
UPC-E +5	I	CC-C	l
EAN-13	B	Korean Postal Authority	c
EAN-13 +2	L	Intelligent mail	0
EAN-13 +5	M	Postal-TNT, KIX	1
EAN-8	A	Japanese postal code	2
EAN-8 +2	J	Postnet	3
EAN-8 +5	K	Australia postal code	4
Code 39	V	US Planet	6
Code 39 Full ASCII	W	UK Postal (Royal mail)	7
Italian Pharmaceutical	Y	4-state Mailmark barcode	8
Codabar	R	Codablock F	E
Codabar ABC	S	Data Matrix	t
Codabar CX	f	Dot Code	k
Industrial 2 of 5	O	Aztec	o
Interleaved 2 of 5	N	Aztec Runes	
S-Code	g	Chinese Sensible Code	e
Matrix 2 of 5	Q	QR Code	u
Chinese Post	w	rMQR Code	j
Code 93	U	Micro QR Code	
IATA	P	Maxi Code	v
MSI/Plessey	Z	PDF417	r
Telepen	d	MicroPDF417	s
UK/Plessey	a	ICAO Travel Documents (OCR)	9
Code 11	b	ISBN and Other OCR Font B	z

**10.1.2 Code Option AIM/ISO15424 Code ID Prefix/Suffix Values**

Symbology	Code ID	Symbology	Code ID
UPC-A	JE0	UK/Plessey	JP0
UPC-A +2	JE3	Code 128	JC0
UPC-A +5	JE3	GS1-128	JC1
UPC-E	JE0	Code 93	JG0
UPC-E +2	JE3	Code 11	JH*
UPC-E +5	JE3		JX0
EAN-13	JE0	Korean Postal Authority	JX0
EAN-13 +2	JE3	Intelligent Mail Barcode	JX0
EAN-13 +5	JE3	POSTNET	JX0
EAN-8	JE4	GS1 DataBar	Je0
EAN-8 +2	JE7	CC-A	Je1
EAN-8 +5	JE7	CC-B	Je1
Code 39	JA*	CC-C	Je1
Code 39 Full ASCII	JA*	GS1 DataBar with CC-A	Je0
Tri-Optic	JX0	GS1 DataBar with CC-B	Je0
Code 39 lt. Pharmaceutical	JX0	GS1 DataBar with CC-C	Je0
Codabar	JF*	Codablock F	JO*
Codabar ABC	JF*	DataMatrix	Jd*
Codabar CX	JX0	Dot Code	JJ**
Industrial 2 of 5	JS0	Aztec	Jz*
Interleaved 2 of 5	Jl*		JX0
S-Code	JX0	QR Code	JQ*
Matrix 2 of 5	JX0	rMQR Code	
Chinese Post	JX0	Micro QR Code	
IATA	JR*	Maxi Code	JU*
MSI/Plessey	JM*	PDF417	JL0
	JX0	MicroPDF417	
Telepen	JB*	OCR	JX0

**Code 39 Option AIM/ISO15424 Code ID: A\***

Code Option	]AIM-ID	Code Option	]AIM-ID
Normal Code 39 (D5) Do not check CD (C1) Transmit CD (D9)	]A0	Full ASCII Code 39 (D4) or Full ASCII Code 39 if pos. (+K) Do not check CD (C1) Transmit CD (D9)	]A4
Normal Code 39 (D5) Check CD (C0) Transmit CD (D9)	]A1	Full ASCII Code 39(D4) or Full ASCII Code 39 if pos. (+K) Check CD (C0) Transmit CD (D9)	]A5
Normal Code 39 (D5) Do not check CD (C1) Do not transmit CD (D8)	]A2	Full ASCII Code 39(D4) or Full ASCII Code 39 if pos. (+K) Do not check CD (C1) Do not transmit CD (D8)	]A6
Normal Code 39 (D5) Check CD (C0) Do not transmit CD (D8)	]A3	Full ASCII Code 39(D4) or Full ASCII Code 39 if pos. (+K) Check CD (C0) Do not transmit CD (D8)	]A7

**Codabar Option AIM/ISO15424 Code ID: F\***

Code Option	]AIM-ID	Code Option	]AIM-ID
Codabar normal mode (HA) Do not check CD (H7) Transmit CD (H8)	]F0	Codabar normal mode(HA) Do not check CD (H7) Do not transmit CD (H9)	]F4
Codabar ABC (H4) or (H3) Do not check CD (H7) Transmit CD (H8)	]F1	Codabar ABC (H4) or (H3) Do not check CD (H7) Do not transmit CD (H9)	]F5
Codabar normal mode (HA) Check CD (H6) Transmit CD (H8)	]F2	Codabar normal mode (HA) Check CD (H6) Do not transmit CD (H9)	]F6
Codabar ABC (H4) or (H3) Check CD (H6) Transmit CD (H8)	]F3	Codabar ABC (H4) or (H3) Check CD (H6) Do not transmit CD (H9)	]F7

**Interleaved 2 of 5 Option AIM/ISO15424 Code ID: I\***

Code Option	]AIM-ID	Code Option	]AIM-ID
Do not check CD (G0) Transmit CD (E0)	]I0	Do not check CD (G0) Do not transmit CD (E1)	]I2
Check CD (G1) Transmit CD (E0)	]I1	Check CD (G1) Do not transmit CD (E1)	]I3

**IATA Option AIM/ISO15424 Code ID: R\***

Code Option	]AIM-ID	Code Option	]AIM-ID
Do not check CD (4H) Transmit CD (4L)	]R0	Do not check CD (4H) Do not transmit CD (4M)	]R2
Check FC and SN only (4I) or Check CPN,FC and SN (4J) or Check CPN,AC,FC and SN (4K) Transmit CD (4L)	]R1	Check FC and SN only (4I) or Check CPN,FC and SN (4J) or Check CPN, AC, FC and SN (4K) Do not transmit CD (4M)	]R3

**MSI/Plessey Option AIM/ISO15424 Code ID: M\*/X0**

Code Option	]AIM-ID	Code Option	]AIM-ID
Check 1CD = MOD 10 (4B): (4B) + Transmit CD1 (4E) or (4B) + Do not transmit CD (4G) or (4B) + Transmit CD1 and CD2 (4F)	]M0 ] ]M1 ]X0	Check 2CD's = MOD 10/MOD 11 (4D): (4D) + Transmit CD1 (4E) or (4D) + Do not transmit CD (4G) or (4D) + Transmit CD1 and CD2 (4F)	]X0
Check 2CD's = MOD 10/MOD 10 (4C): (4C) + Transmit CD1 (4E) or (4C) + Do not transmit CD (4G) or (4C) + Transmit CD1 and CD2 (4F)	]X0	Check 2CD's = MOD 11/MOD 10 (4R): (4D) + Transmit CD1 (4E) or (4D) + Do not transmit CD (4G) or (4D) + Transmit CD1 and CD2 (4F)	]X0

**Telepen Option AIM/ISO15424 Code ID: B\***

Code Option	]AIM-ID	Code Option	]AIM-ID
Telepen (numeric or ASCII only): ASCII mode (D3) Numeric mode (D2)	]B0 ] ]B1	Telepen (numeric followed by ASCII): ASCII mode (D3) Numeric mode (D2)	]B0 ] ]B2
Telepen (ASCII followed by numeric) (not supported): ASCII mode (D3) Numeric mode (D2)	]B0 ] ]B2		

**Code 11 Option AIM/ISO15424 Code ID: H\*/X0**

Code Option	]AIM-ID	Code Option	]AIM-ID
Check 1CDs (BLG) or Check auto 1 or 2CDs (BLI) (length > 12) Transmit CD <sub>(S)</sub> (BLK)	]H0	Check 1CDs (BLG) or Check 2CDs (BLH) or Check auto 1 or 2CDs (BLI) (length > 12) Not transmit CD <sub>(S)</sub> (BLJ)	]H3
Check 2CDs (BLH) or Check auto 1 or 2CDs (BLI) (length > 12) Transmit CD <sub>(S)</sub> (BLK)	]H1	Do not check CD (BLF) Do not transmit CD (BLJ)	]X0

**Codablock F Option AIM/ISO15424 Code ID: O\***

Code Option	]AIM-ID	Code Option	]AIM-ID
FNC1 not used	]O4	FNC1 in 1st position	]O5

**DataMatrix Options AIM/ISO15424 Code ID: d\***

Code Option	]AIM-ID	Code Option	]AIM-ID
ECC000-ECC140	]d0	ECC200, supporting ECI protocol	]d4
ECC200	]d1	ECC200,FNC1 in 1st or 5th position and supporting ECI protocol	]d5
ECC200, FNC1 IN 1st or 5th position	]d2	ECC200,FNC1 in 2nd or 6th position and supporting ECI protocol	]d6
ECC200, FNC1 IN 2nd or 6th position	]d3		

**Aztec Options AIM/ISO15424 Code ID: z\***

Code Option	]AIM-ID	Code Option	]AIM-ID
No structure/other	]z0	Structured append header included, FNC1 following an initial letter or pair of digits	]z8
FNC1 preceding 1st message character	]z1		
FNC1 following an initial letter or pair of digits	]z2	Structured append header included and ECI protocol implemented	]z9
ECI protocol implemented	]z3		
FNC1 preceding 1st message character and ECI protocol implemented	]z4	Structured append header included, FNC1 preceding 1st message character, ECI protocol implemented	]zA
FNC1 following an initial letter or pair of digits, ECI protocol implemented	]z5		
Structured append header included	]z6	Structured append header included, FNC1 following an initial letter or pair of digits, ECI protocol implemented	]zB
Structured append header included and FNC1 preceding 1st message character	]z7		
		Aztec runes	]zC

**QR Code Option AIM/ISO15424 Code ID: Q\***

Code Option	]AIM-ID	Code Option	]AIM-ID
Model 1	]Q0	Model 2, ECI protocol implemented	]Q4
Model 2, ECI protocol not implemented	]Q1	FNC1 in first position	
Model 2, ECI protocol implemented	]Q2	Model 2, ECI protocol not implemented	]Q5
Model 2, ECI protocol not implemented FNC1 in first position	]Q3	FNC1 in second position	
		Model 2, ECI protocol implemented FNC1 in second position	]Q6

**Maxi Code Option AIM/ISO15424 Code ID: U\***

Code Option	]AIM-ID	Code Option	]AIM-ID
Symbol in mode 4 of 5	]U0	Symbol in mode 4 of 5, ECI protocol implemented	]U2
Symbol in mode 2 of 3	]U1	Symbol in mode 2 of 3, ECI protocol implemented	]U3

## 10.2 MDI-4600 and MDI-4700 Specification Overview

### 10.2.1 Common Specification Overview

Specification		Description	Notes	
Interface	UART	300 bps to 921600 bps	Default: 9600 bps	
	USB	Full Speed 12Mbps ( HID/COM )		
Optical Section	Scanning method	Monochrome 640x480 CMOS area sensor	Frame rate:120 fps	
	Scanning light source	1 warm white LED		
	Aiming light source	Single line green LED		
	Effective pixels	0.30 million pixels (H: 640 x V: 480)		
	View angle	Horizontal: about 38.0° Vertical: about 26.4° Diagonal: about 46.4°		
Supported 1D Symbologies	Symbologies	1D:	UPC-A, UPC-E, UPC-A Add-on , UPC-E Add-on, EAN-13, EAN-8, EAN-13 Add-on/EAN-8 Add-on, JAN-8, JAN-13, Code 39, Codabar, Industrial 2 of 5, Interleaved 2 of 5, Code 93, Code 128, GS1-128, MSI/Plessey, Code 11, Japanese Postal, Intelligent Mail Barcode, POSTNET, PLANET, Netherlands KIX Code, UK Postal, Australian Postal, Korean Postal Authority code	
		Postal:		
GS1/Composite	Symbologies	GS1 DataBar, GS1 DataBar Limited, GS1 DataBar Expanded, Composite, GS1 DataBar, Composite GS1-128, Composite EAN, Composite UPC	GS1 DataBar: formerly called "RSS"	
Supported 2D Symbologies	Symbologies	PDF417, MicroPDF417, Codablock F, QR Code , Micro QR Code, rMQR Code DataMatrix(ECC 0 - 200), MaxiCode, Aztec Code, Chinese Sensible Code, Dot Code	Disable Code 128 when Codablock F is enabled.	
OCR	OCR font	Machine Readable Travel Documents OCR –A/B, E-13B(MICR)		
Power	Range of operating voltage	3.3/5.0 V (3.0~5.5V)		
	Current consumption	See " <a href="#">Current Consumption of the MDI-4600 and MDI-4700</a> ".	Ambient temperature: 25°C	
Environmental Specifications	Temperature	Operating:	-20 to 60 °C	AC adapter 0 to 40°C
		Storage:	-40 to 70 °C	
	Humidity	Operating:	5 to 90% (no condensing, no frost)	
		Storage:	5 to 90% (no condensing, no frost)	
	Ambient light immunity	Fluorescent:	10,000 lx or less	UPC 0.33 mm
		Sunlight:	100,000 lx or less	

**Technical Specifications**  
**Standard Range Model (SR) Specifications**

Specification	Description	Notes
Minimum Resolution	Code 39: 0.076 mm (3 mil)	OPTOELECTRONICS test chart
	GS1 DataBar: 0.127 mm (5 mil)	
	Composite Code: 0.127 mm (5 mil)	
	PDF417: 0.127 mm (5 mil)	
	QR Code: 0.127 mm (5 mil)	
	Data Matrix: 0.127 mm (5 mil)	
Barcode Width	Possible to read: Width 100 mm Code 39 Resolution 0.2 mm (DOF: 170 mm)	
Motion Tolerance	Possible to read: UPC 100% moving at 10 m/s (DOC: 130 mm)	

**Standard Range Model (SR) Reading Depth of Field**

 (T<sub>A</sub> = 25°C)

Resolution mm (mil)	Symbology Type	PCS (MRD)	Guaranteed Value		Typical Value	
			Near	Far	Near	Far
0.076 mm (3 mil)	Code 39	0.9 (80)	59 mm (2.3")	87 mm (3.4")	50 mm (2.0")	108 mm (4.2")
0.127 mm (5 mil)	Code 39	0.9 (80)	50 mm (2.0")	151 mm (5.9")	38 mm (1.5")	221 mm (8.7")
0.254 mm (10 mil)	Code 39	0.9 (80)	52 mm (2.1")	261 mm (10.3")	44 mm (1.7")	365 mm (14.3")
0.508 mm (20 mil)	Code 39	0.9 (80)	68 mm (2.7")	443 mm (17.4")	59 mm (2.3")	603 mm (23.7")
0.2 mm (7.9 mil)	Code 128	0.9 (80)	68 mm (2.7")	189 mm (7.4")	59 mm (2.3")	291 mm (11.5")
0.33 mm (13 mil)	UPC/EAN	0.9 (80)	49 mm (1.9")	328 mm (12.9")	42 mm (1.7")	445mm (17.5")
0.127 mm (5.0 mil)	PDF417	0.9 (80)	51 mm (2.01")	102 mm (4.0")	40 mm (1.6")	118 mm (6.7")
0.254 mm (10 mil)	PDF417	0.9 (80)	52 mm (2.1")	192 mm (7.6")	46 mm (1.8")	230 mm (9.0")
0.127 mm (5.0 mil)	QR Code	0.9 (0.8)	72mm (2.8")	84 mm (3.1")	55 mm (2.2")	93 mm (3.6")
0.381 mm (15 mil)	QR Code	0.9 (80)	39mm (1.5")	231 mm (9.1")	30 mm (1.2")	260 mm (10.2")
0.127 mm (5.0 mil)	Data Matrix	0.9 (80)	77 mm (2.7")	88 mm (2.9")	56 mm (2.2")	98 mm (3.8")
0.254 mm (10 mil)	Data Matrix	0.9 (80)	39 mm (1.5")	155 mm (6.1")	31 mm (1.2")	173 mm (6.8")

**Notes:** The depth of field is the typical value measured by tilting the test chart 15° from the optical axis.  
 The depth of field is a determined while using the OPTOELECTRONICS test chart PCS 0.9, without specular reflection and at room temperature and room humidity.

## 10.2.2 MDI-4700 Drawing

### MDI-4700 Detailed View

Dimensions (approximately): 21 mm (D) × 25.3 mm (W) × 10.0 mm (H)

Weight (max): 7.1 g

Mechanical Drawing:

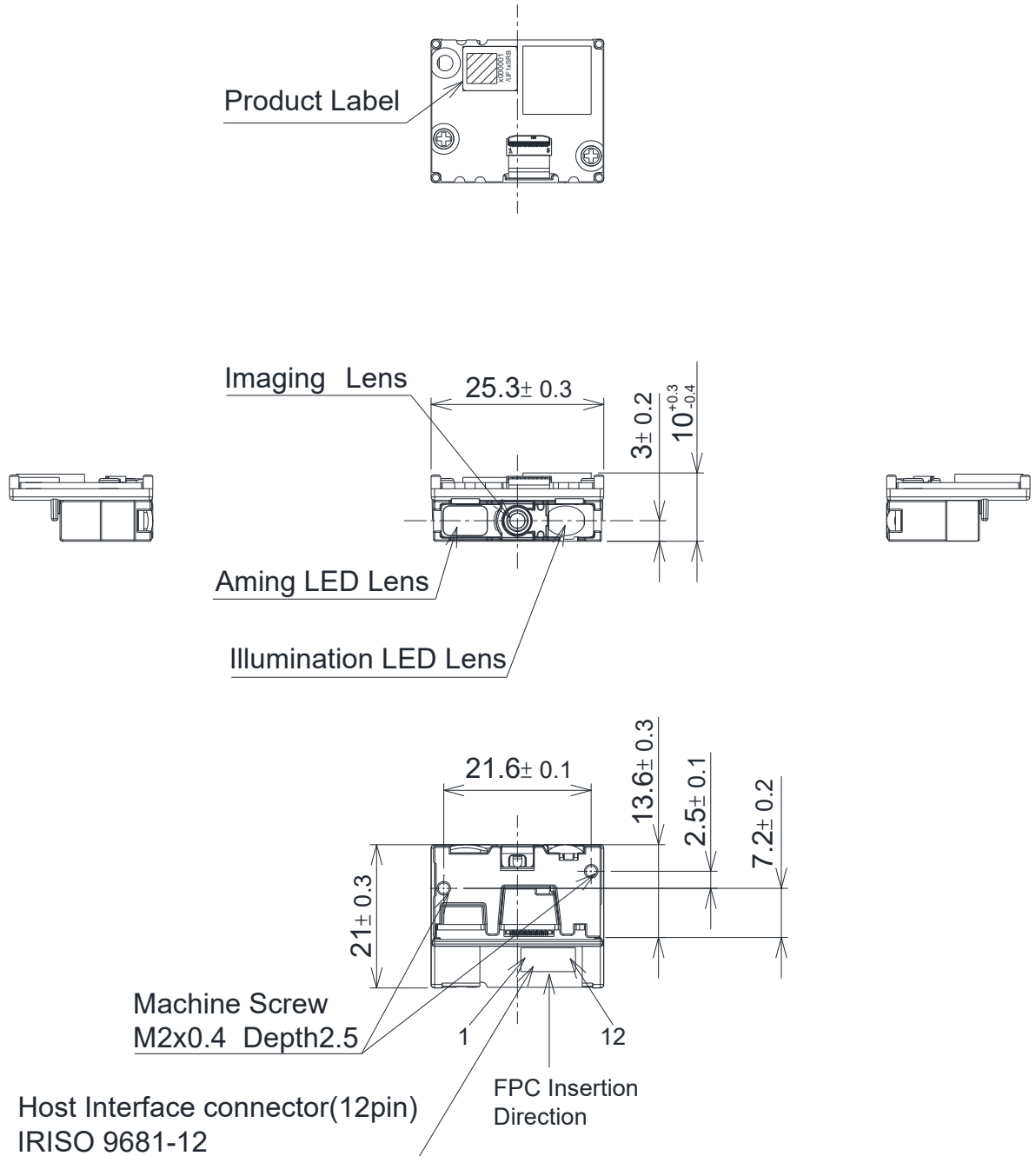

### MDI-4600 Detailed View

Dimensions (approximately):

Camera: 13.6 mm (D) × 24.6 mm (W) × 6 mm (H)

Decoder board (DBM-4600): 20.8 mm (D) × 25.1 mm (W) × 3.5 mm (H)

Weight (max): 6.4 g

Mechanical Drawing:

MDI-4600 Camera Engine

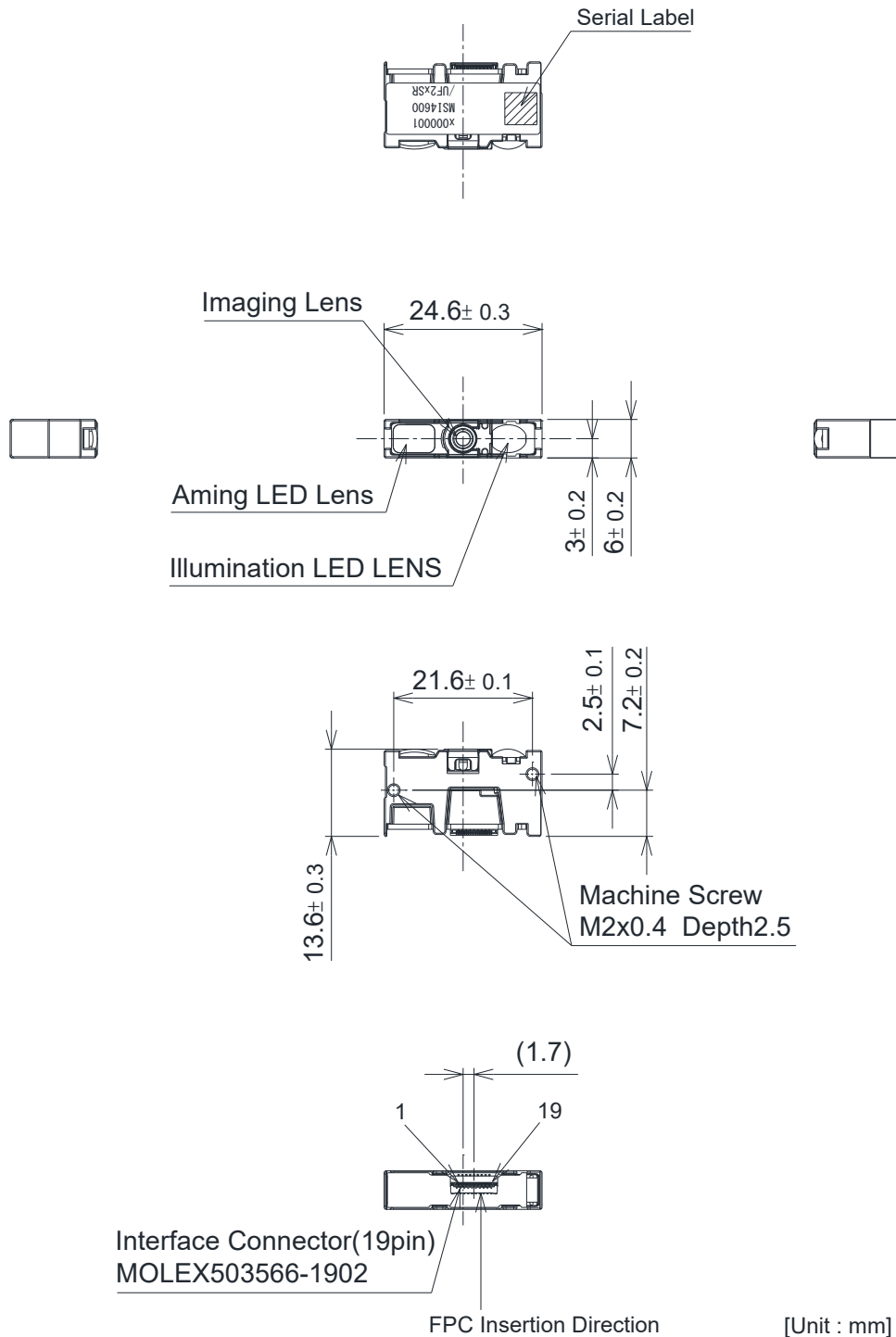

[Unit : mm]

## DBM-4600 Decoder Board

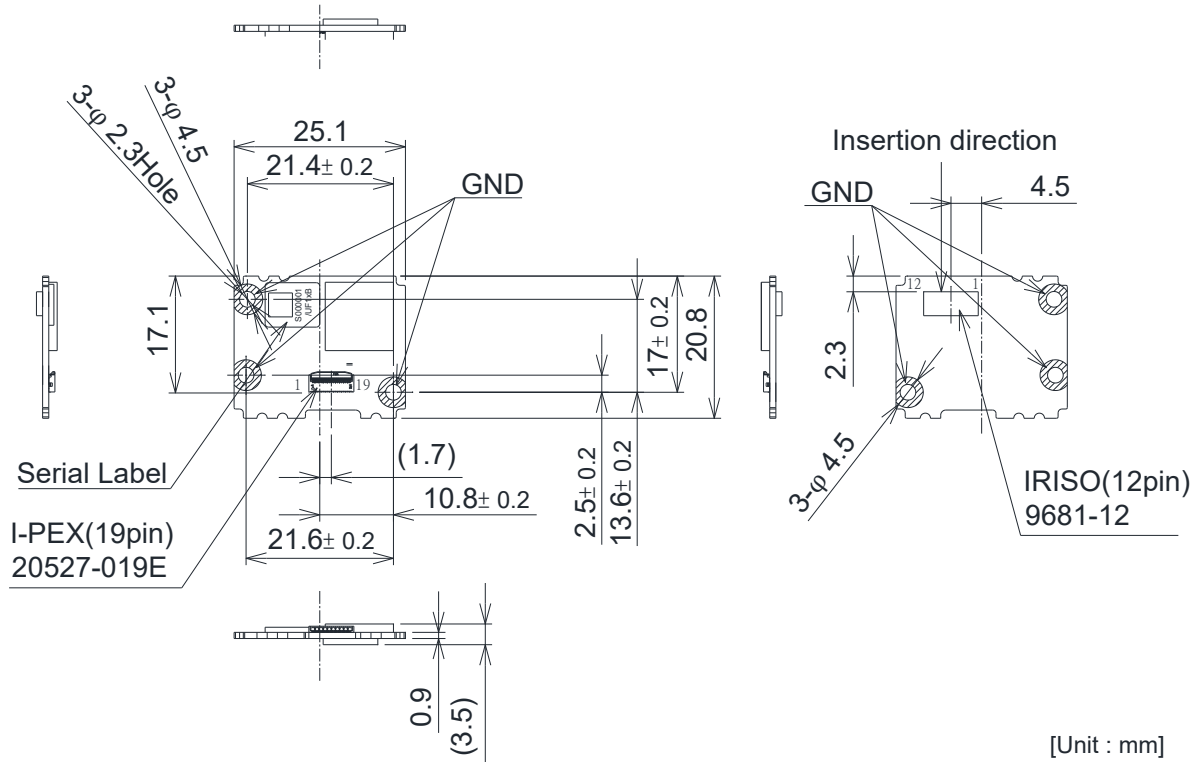

## FPC Cable

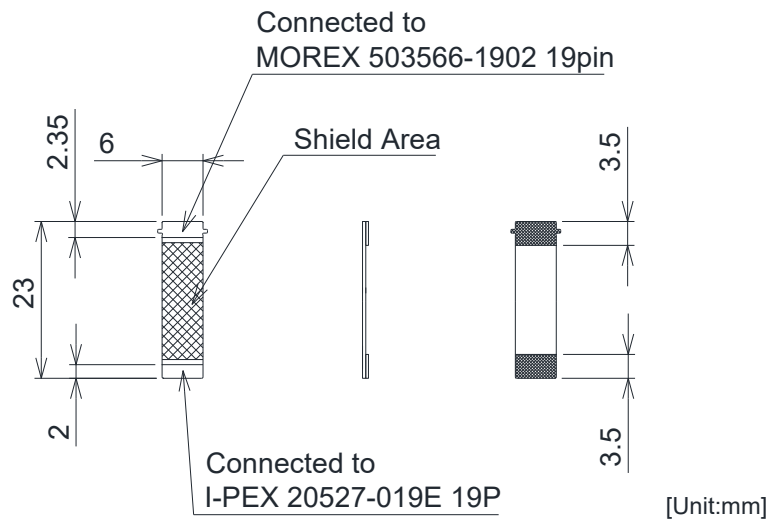

## 10.3 Sample Codes

---

### 10.3.1 1D Code

#### UPC

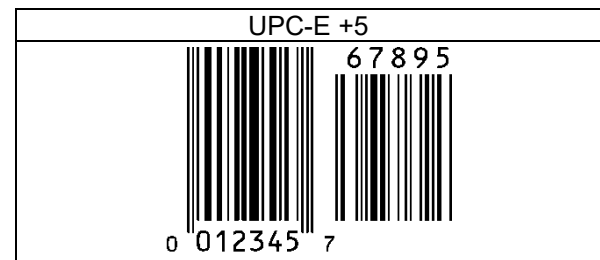
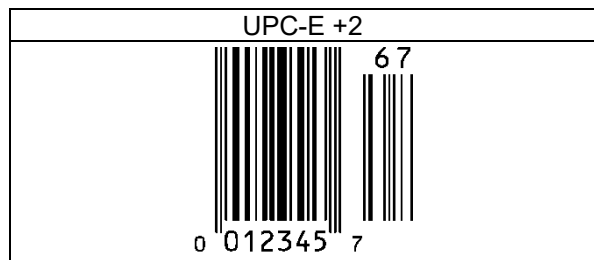
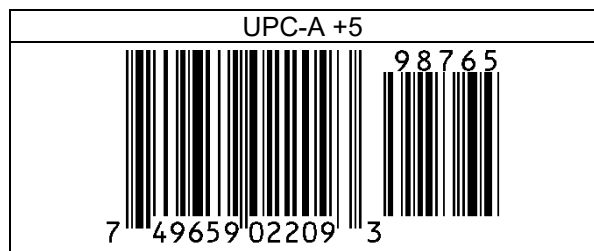
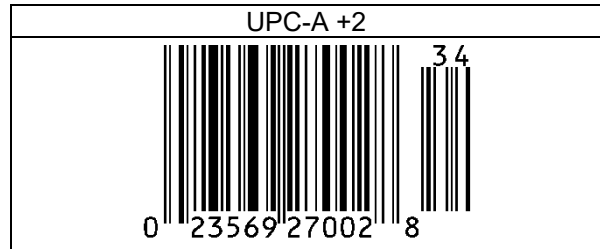
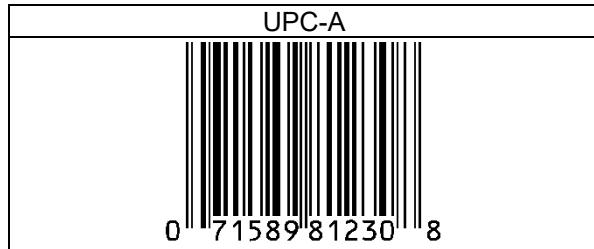

## EAN/JAN

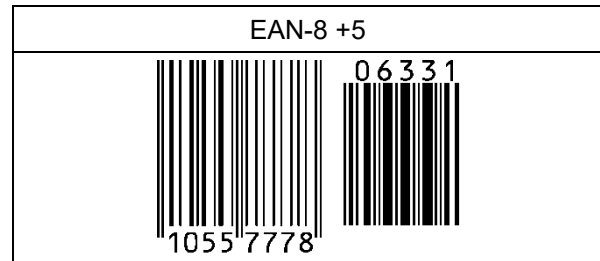
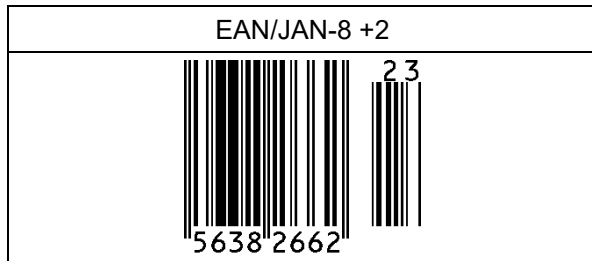
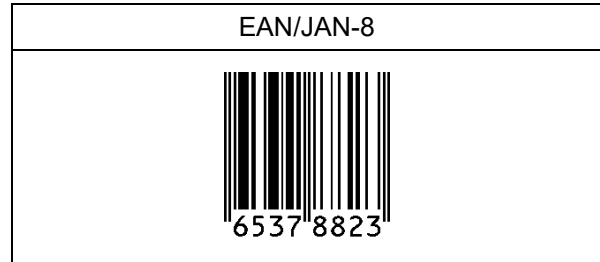

### Code 39

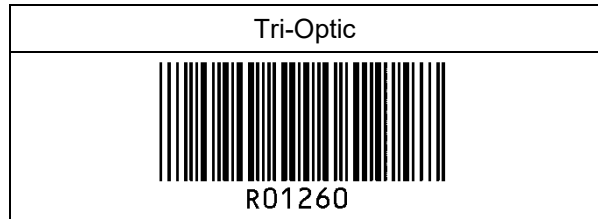
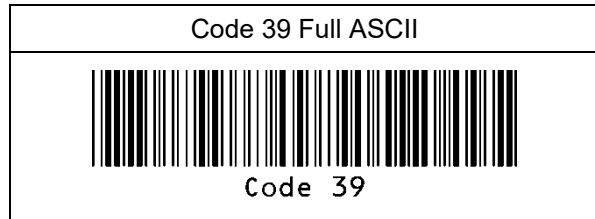
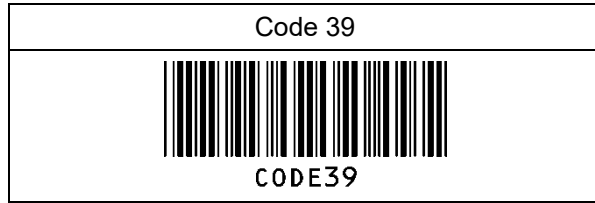

### Codabar

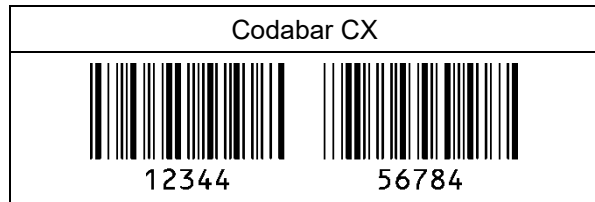

### Industrial 2 of 5/Interleaved 2 of 5



### Code 128

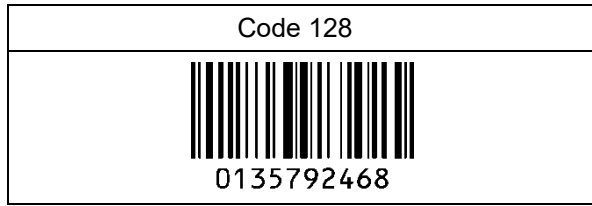

### Code 93

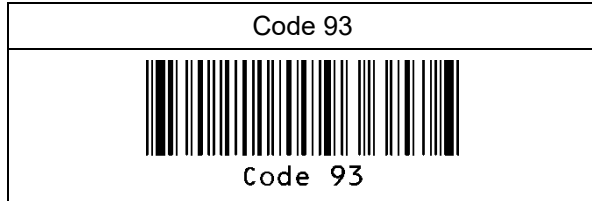

### IATA



### MSI/Plessey



### UK/Plessey



### Telepen









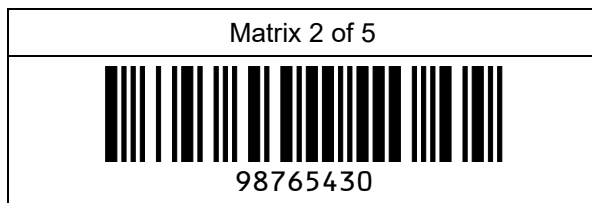

### Code11

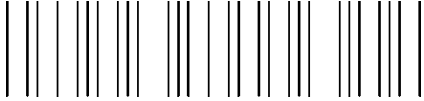

### Matrix 2 of 5



### 10.3.2 Postal Code

Chinese Post Matrix 2 of 5	Korean Postal authority
 01647100611	 345-678
Intelligent Mail Barcode	
 94765432101234567890	
POSTNET	
 012340	
PLANET	
 012345678905	
Japan Postal	
 33500024-12-17	
Netherland KIX Code	
 3992RK28	
Australian Postal	
 56439111ABA9	
UK Postal(Royal mail)	
 12345678	
4-State Mailmark Barcode	
 41038422416563762EF61AH8T	

### 10.3.3 GS1 DataBar

GS1 DataBar Omnidirectional



0165473728281919

GS1 DataBar Truncated



0100012345678905

GS1 DataBar Stacked



(01)04912345678904

GS1 DataBar Stacked Omnidirectional



(01)04912345678904

GS1 DataBar Limited



(01)04912345678904

GS1 DataBar Expanded



(01)04912345678904  
(17)200815  
(10)0145678

GS1 DataBar Expanded Stacked

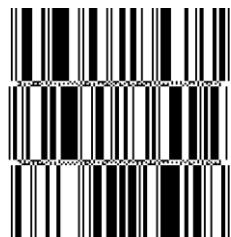

(01)04912345678904  
(17)200815  
(10)0145678  
(21)0802

### 10.3.4 GS1 Composite Code

**CC-A**

(17) 120903  
(10) CCA



(01) 0 4912345 67890 4

**CC-B**

(17) 120903  
(10) CCB  
(240) 123456789omnidirectionalccb



(01) 0 4912345 67890 4

**Limited CC-A**

(17) 170330 (10) ABCCA



(01) 1 4512345 67890 3

**Limited CC-B**

(17) 170330  
(10) ABCCB  
(240) 12345678limitedccb



(01) 1 4512345 67890 3

**Expanded CC-A**

(17) 890805  
(10) CCA



(01) 00000123000017

**Expanded CC-B**

(17) 890805  
(10) CCB  
(240) 1U16C19A876B54T3210expandedccb



(01) 00000123000017

### Composite GS1-128

**CC-A**

(17) 201231 (10) GS1128CCA



(01) 2 0012345 67890 9

**CC-B**

(17) 201231  
(10) GS1128CCB  
(240) 123456789 gs1-128\_ccb



(01) 2 0012345 67890 9

**CC-C**

(17) 201231  
(10) GS1128CCC



(01) 2 0012345 67890 9

## Composite EAN

**EAN-13 CC-A**

0123456789548  
(17) 120304  
(10) EANCCA



**EAN-13 CC-B**

0123456789548  
(17) 120304  
(10) EANCCB  
(240) 21U16C19A876B54T3210ean13cc-b



**EAN-8 CC-A**

12345670  
(17) 160401  
(10) EAN8CCA



**EAN-8 CC-B**

12345670  
(17) 170408  
(10) EAN8CCB  
(240) 12345678ean8ccb



## Composite UPC

**UPC-A CC-A**

314159265358  
(17) 170809  
(10) UPCCCA



**UPC-A CC-B**

314159265358  
(17) 170809  
(10) UPCCCB  
(240) 21U16C19A876B54T3210UPCCCB



**UPC-E CC-A**

01234565  
(17) 040104  
(10) UPCECCA



**UPC-E CC-B**

01234565  
(17) 040104  
(10) UPCECCB  
(240) 12345678upceccb



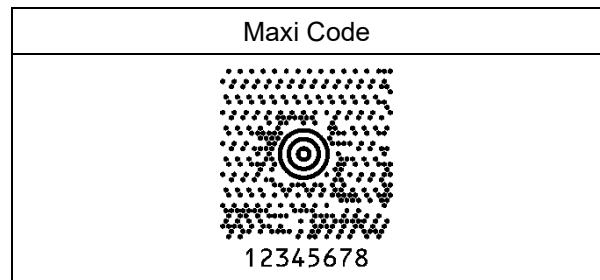
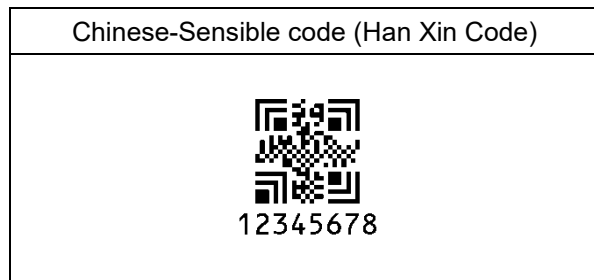
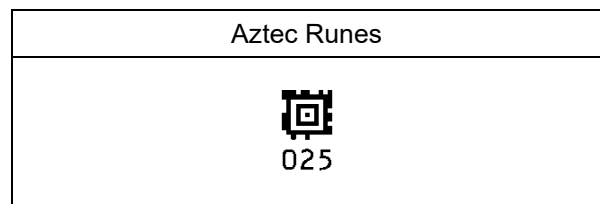
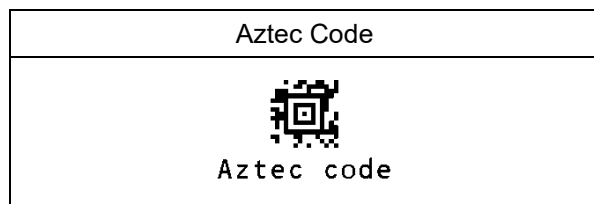
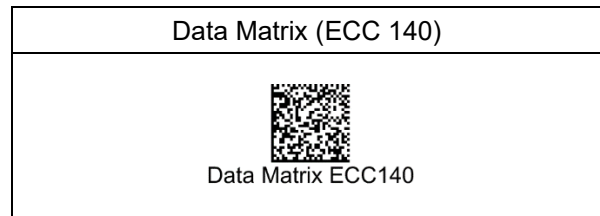
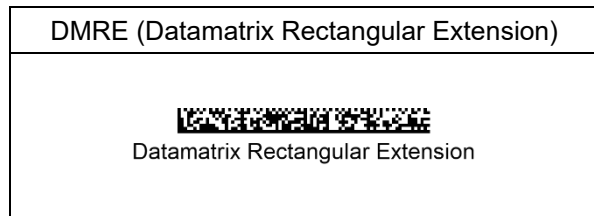
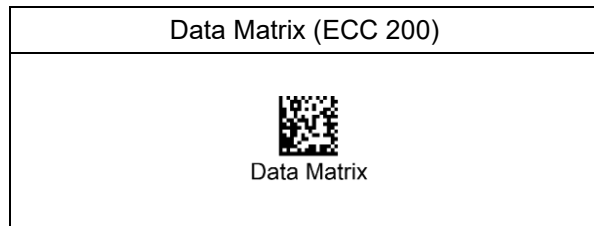
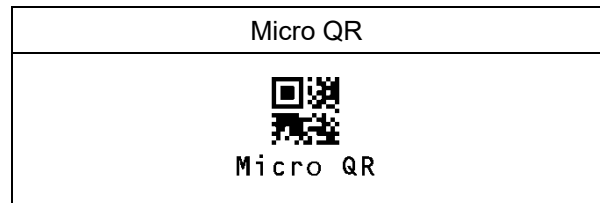
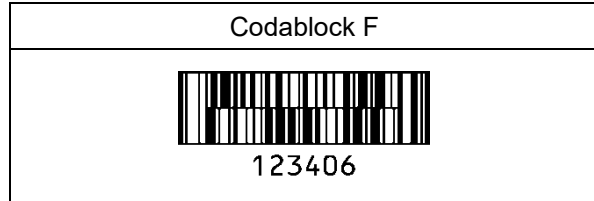
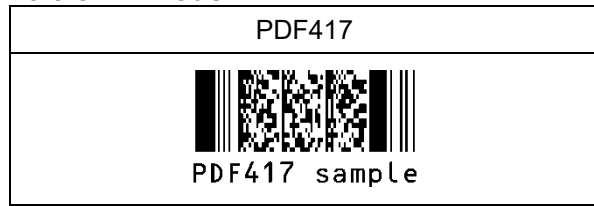

### 10.3.5 2D Code

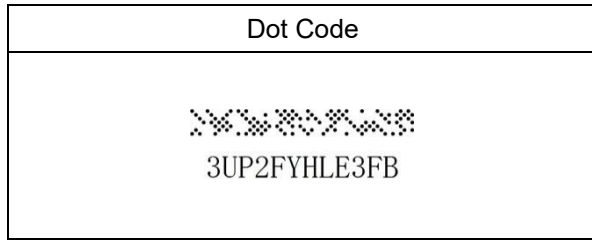





### 10.3.7 OCR Font (Free OCR Edit)

OCR-A		OCR-B	
OCR-A Free Edit Enable		OCR-A Free Edit Enable	
4567890		345678	
0123456789012		89012345678	
DEFGHIJ		FGHIJKLMN	
23456CDEFGH		56789012ABCD	
Free Edit Disable			

## 10.4 Imager Engine Software Information

---

- The imager engine includes software licensed under the MIT-License.
- The imager engine includes software licensed under the OpenBSD License.
- This software is based in part on the work of the Independent JPEG Group.
- The imager engine includes software licensed under the Apache License.

For more information on these licenses and disclaimers, refer to the URL displayed by sending the Software Information command.

Parameter	Command	Description
Software Information	[OSS	Output software information

Please refrain from making inquiries regarding the contents of the source code you have obtained.

Transferring, copying, disassembling, decompiling, and reverse engineering of the software included in this device is prohibited.